

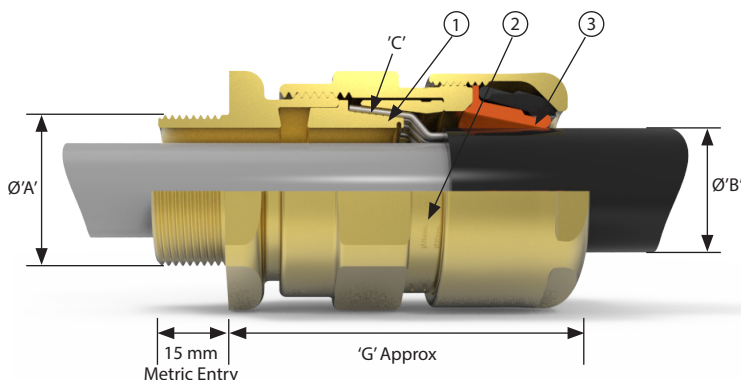

151/RAC

Industrial gland for indoor or outdoor use



Features

- Reversible Armour Clamp - For all types of armour and braid
- Patented Cable Gland Tightening Guide - Helps prevent damage caused by over tightening
- Unique Rear Seal - Offering ultimate sealing over an extremely wide cable acceptance range

The 151/RAC Cable Gland is an industrial gland for indoor or outdoor use, robust and for use with single wire armour, wire braid, steel tape armour, elastomer and plastic insulated cables. The gland provides a low smoke, zero halogen IP and retention seal onto the cable outer sheath.

Cable Gland Selection Table

Size Ref.	Entry Thread Size		Cable Acceptance Details					'G'	Hexagon Dimensions	
	Metric	NPT*	Inner Sheath 'ØA'	Outer Sheath 'ØB'		Armour Braid 'C'			Across Flats	Across Corners
				Max	Min	Max	Orientation 1			
Os	M20 ²	½"	8.0	5.5	12.0	0.8 / 1.25	0.0 / 0.8	52.0	24.0	26.5
O	M20 ²	½"	11.9	9.5	16.0	0.8 / 1.25	0.0 / 0.8	53.0	24.0	26.5
A	M20	¾" or ½"	14.3	12.5	20.5	0.8 / 1.25	0.0 / 0.8	53.0	30.0	32.5
B	M25	1" or ¾"	20.2	16.9	26.0	1.25 / 1.6	0.0 / 0.7	69.5	36.0	39.5
C	M32	1¼" or 1"	26.5	22.0	33.0	1.6 / 2.0	0.0 / 0.7	64.0	46.0	50.5
C2	M40	1½" or 1¼"	32.5	28.0	41.0	1.6 / 2.0	0.0 / 0.7	68.3	55.0	60.6
D	M50	2" or 1½"	44.4 / 42.3 ¹	36.0	52.6	1.8 / 2.5	0.0 / 1.0	79.0	65.0	70.8
E	M63	2½" or 2"	56.3 / 54.3 ¹	46.0	65.3	1.8 / 2.5	0.0 / 1.0	78.9	80.0	88.0
F	M75	3" or 2½"	68.2 / 65.31	57.0	78.0	1.8 / 2.5	0.0 / 1.0	83.7	95.0	104.0
G	M80	3½"	73.0	75.0	89.5	2.0 / 3.5	0.0 / 1.0	95.6	106.4	115.0
H	M90	3½"	77.6	75.0	89.5	2.0 / 3.5	0.0 / 1.0	95.6	115.0	130.0
J	M100	4"	91.6	88.0	104.5	2.5 / 4.0	0.0 / 1.0	95.6	127.0	142.0

All dimensions in millimetres (except * where dimensions are in inches).
 Os - F size metric entry threads are 1.5mm pitch as standard, 15mm length of thread.
 G - J size metric entry threads are 2mm pitch as standard, 20mm length of thread.

¹Smaller value is applicable when selecting reduced NPT entry option.
²Sizes Os and O are available with an M16 thread size. For O size with M16 thread, the maximum cable outer sheath diameter is 10.9mm

Technical Data

Material Options	Manufactured in Brass, Nickel Plated Brass or 316L Stainless Steel
Construction & Test Standards	IEC/EN 62444 (Anchorage Type D)
Ingress Protection	IP66 to IEC/EN 60529
Enclosure Protection	IK10 to IEC 62262
Operating Temperature	-60°C to +100°C

Alternative Reversible Armour Clamping Ring Size Selection

Size Ref	Orientation 1	Orientation 2
B	0.9 - 1.25	0.5 - 0.9
C	1.2 - 1.6	0.6 - 1.2
C2	1.2 - 1.6	0.6 - 1.2
D	1.45 - 1.8	1.0 - 1.45
E	1.45 - 1.8	1.0 - 1.45
F	1.45 - 1.8	1.0 - 1.45

Ordering Information

If brass is required please omit material selection
 Format for ordering is as follows: Alternative Ring (R), add suffix R to ordering information

Cable Gland Type	Size	Thread	Material	(Optional)
151R	C	M32		R
151R	C	1.25	NP	R

Order Example: 151RCM32R

Please note all NPT entries should be state as a decimal
 Please refer to part code logic information page for further details on product options

Cable Gland Tightening Guide

Whilst Hawke International goes to great lengths to ensure products are designed to be as simple to install, inspect and maintain as is possible, differing levels of competency, training and understanding can lead to glands being incorrectly installed. With hazardous area products, any poor installation issues can not only lead to expensive equipment failure, but also potential explosion risks and associated risk to life.

To help address issues with the overtightening of cable glands and the resultant damage to cables and seals, Hawke International has developed the patented **INBUILT TIGHTENING GUIDE**.

Without the need for fiddly measuring systems, the guide provides a permanent visual indication of the gland tightness through installation, inspection and maintenance.

How it works

The gland is permanently marked with various lines/numbers indicating the correct tightening level related to the cable diameter. Following the relevant cable gland Installation Instructions, the back seal should be tightened until a seal is formed on the cable outer sheath and then tightened one further turn.



Step 1
Follow cable gland installation instructions until final stage – tightening of rear seal



Step 2
Tighten backnut until a seal is formed onto the cable, then tighten one further turn



Step 3
The backnut should be level with the marking guide corresponding to its diameter – this can be visually inspected and adjusted as necessary

Note: The cable gland installation instructions have a printed cable OD measure for if the cable OD is not known