

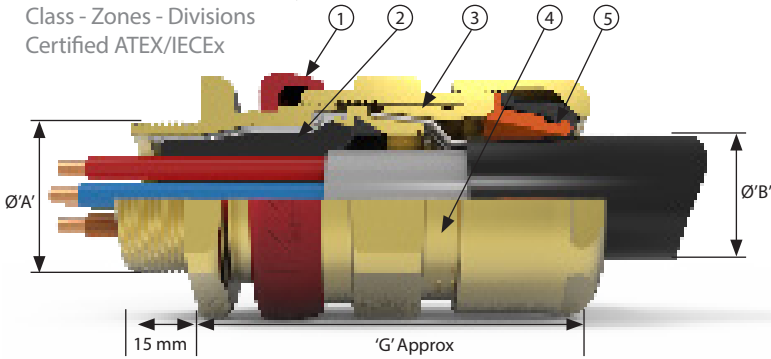

# ICG/653/UNIV/L

Flameproof, Increased Safety, Dust Protection  
Class - Zones - Divisions  
Certified ATEX/IECEx



- 1 Inspectable Deluge Seal - Offering IP66, IP67, IP68 & IP69 Ingress Protection
- 2 Transparent Elastomeric Fully Inspectable Compound Pot – compatible with both injectable resin and 2 part compound
- 3 Reversible Armour Clamp - For all types of armour and braid
- 4 Electrical Bond on the cables lead inner sheath
- 5 Patented Cable Gland Tightening Guide - Helps prevent damage caused by over tightening
- 6 Unique Rear Seal - Offering ultimate sealing over an extremely wide cable acceptance range.

Dual certified Exe/Exd barrier gland, providing a seal around individual cable cores, especially for cables that exhibit "cold flow" characteristics, are not effectively filled or have hygroscopic fillers. For use with single wire armour 'W', wire braid 'X', steel tape armour 'Z' elastomer and plastic insulated cables. The ICG/653/UNIVERSAL is available with either ExPress liquid barrier resin or QSP 2-part hand mix compound, both with a cure time of 30 minutes

## Cable Gland Selection Table

Size Ref.	Entry Thread Size 'A'		Cable Acceptance Details								'G'	Hexagon Dimensions	
	Metric	NPT* Standard or Option	Inner Sheath/Cores 'A'				Outer Sheath 'B'		Armour Braid 'C'			Across Flats	Across Corners
			Max Inner Sheath 'E'	Max Over Core Diameter	Max No of Cores	Max No of Fibre Optic	Min	Max	Orientation 1	Orientation 2			
Os	M20 <sup>2</sup>	½"	8.1**	8	12	48	5.5	12	0.8 / 1.25	0.0 / 0.8	58.4	24	26.5
O	M20 <sup>2</sup>	½"	10.2	8.8	12	48	9.5	16	0.8 / 1.25	0.0 / 0.8	58.4	24	26.5
A	M20	¾" or ½"	12.5	10.8	15	72	12.5	20.5	0.8 / 1.25	0.0 / 0.8	60.6	30	32.5
B	M25	1" or ¾"	18.0	15.9	30	144	16.9	26	1.25 / 1.6	0.0 / 0.7	67.3	36	39.5
C	M32	1¼" or 1"	24.3	21.9	42	-	22	33	1.6 / 2.0	0.0 / 0.7	73.2	46	50.5
C2	M40	1½" or 1¼"	30.3	26.7	60	-	28	41	1.6 / 2.0	0.0 / 0.7	78.3	55	60.6
D	M50	2" or 1½"	41.9	37.7	80	-	36	52.6	1.8 / 2.5	0.0 / 1.0	97.5	65	70.8
E	M63	2½" or 2"	52.9	49	100	-	46	65.3	1.8 / 2.5	0.0 / 1.0	93.5	80	88
F	M75	3" or 2½"	64.9	59.8	120	-	57	78	1.8 / 2.5	0.0 / 1.0	104.5	95	104

1. All dimensions in millimetres (except \* where dimensions are in inches). Metric entry threads are 1.5mm pitch as standard, 15mm length of thread.  
2. Are available with M16 entry thread, which reduces Max Over Core Diameter to 7mm.

\*\*Recommended value to suit integrated Express resin stop. May be increased to 10.0 if QSP compound or alternative Express resin stop method are used.

## Technical Data

Ingress Protection	IP66, IP67, IP68 (30 metres for 7 days, special conditions may apply), IP69 to IEC/EN 60529 and NEMA 4X
Deluge Protection	to DTS01
Operating Temperature	-60°C to +80°C

### ATEX/IECEx

ATEX/IECEx Protection Class	Ex II 2GD Ex db IIC Gb; Ex eb IIC Gb; Ex nR IIC Gc; Extb IIIC Db
ATEX Certificate No	CML 18ATEX1268X CML 19ATEX4507 (Ex nR)
IECEx Certificate No	CML 18.0131X
Construction & Test Standards	IEC/EN 60079-0, IEC/EN 60079-1, IEC/EN 60079-7, IEC/EN 60079-15 and IEC/EN 60079-31
Marine Approvals	DNV: TAE0000BS
Additional Certifications	CCC: 2020312313000317 CNEX: CNEx17 2858X EAC: TC RU C-GB HA91 B 0046 19 EQM: 20-11-27224/Q20-11-000979/NB0007 Inmetro: IEx 14.0272X KCs: 17-KA4BO-0159X to 0167X PESO: P450038 SONCAP: LCOGB049552-0500

### NEC/CEC

NEC Protection Class	Class I Div 1 ABCD Class II Div 2 EFG and Class III Class I, Zone I, AEx db IIC Gb, AEx eb IIC Gb; Zone 21, AEx tb IIIC Db
CEC Protection Class	Class I Div 1 ABCD Class II Div 2 EFG and Class III Ex db IIC Gb; Ex eb IIC Gb; Ex tb IIIC Db
c CSA us Certificate	1024328
Construction & Test Standards	UL2225, UL1203, UL514B, CSA C22.2 NO. 0-10, CSA C22.2 NO. 174-18, CSA 22.2 60079-0, CSA 22.2 60079-1, CSA 22.2 60079-7 and CSA 22.2 60079-31

Alternative Reversible Armour Clamping Ring Size Selection		
Size Ref	Orientation 1	Orientation 2
B	0.9 - 1.25	0.5 - 0.9
C	1.2 - 1.6	0.6 - 1.2
C2	1.2 - 1.6	0.6 - 1.2
D	1.45 - 1.8	1.0 - 1.45
E	1.45 - 1.8	1.0 - 1.45
F	1.45 - 1.8	1.0 - 1.45

### Ordering Information

Format for ordering is as follows: Alternative Seal (AR), add suffix AR to ordering information

Cable Gland Type	Size	Thread	Barrier Type	Material	(Optional)
ICG 653/UNIV/L	C	M32	(Standard 2 part compound)	Brass	AR
ICG 653/UNIV/L	C	1 1/4 "	EP (ExPress Resin)	Brass	AR

*Two part sealing compound and assembly instructions are supplied with the cable gland*  
 Example Code: ICG 653/UNIV C M32 EP Stainless Steel

# Barrier Gland Options

ExPress barrier resin – a liquid injectable and fast curing resin, allowing for faster installation time than traditional 2-part compounds. Utilising a unique clear compound chamber allowing full visibility of the flameproof seal during installation and inspection, the ExPress barrier resin is unparalleled as a global Exd solution.

QSP 2-part hand mix putty, simple to use with a cure time from 30 minutes. Particularly useful where termination space is limited or cables are running horizontally to the installation area. Can be inspected and repaired if necessary, allowing for the very highest level of safety.

# Cable Gland Tightening Guide

Whilst Hawke International goes to great lengths to ensure products are designed to be as simple to install, inspect and maintain as is possible, differing levels of competency, training and understanding can lead to glands being incorrectly installed. With hazardous area products, any poor installation issues can not only lead to expensive equipment failure, but also potential explosion risks and associated risk to life.

To help address issues with the overtightening of cable glands and the resultant damage to cables and seals, Hawke International has developed the patented **INBUILT TIGHTENING GUIDE**.

Without the need for fiddly measuring systems, the guide provides a permanent visual indication of the gland tightness through installation, inspection and maintenance.

## How it works

The gland is permanently marked with various lines/numbers indicating the correct tightening level related to the cable diameter. Following the relevant cable gland Installation Instructions, the back seal should be tightened until a seal is formed on the cable outer sheath and then tightened one further turn.



Follow cable gland installation instructions until final stage – tightening of rear seal



Tighten backnut until a seal is formed onto the cable, then tighten one further turn



The backnut should be level with the marking guide corresponding to its diameter – this can be visually inspected and adjusted as necessary

*Note: The cable gland installation instructions have a printed cable OD measure for if the cable OD is not known*