

ENCLOSURES

SJIC SERIES



SJIC ENCLOSURES ONLY • SCREW COVER

TECHNE-TERM 



SJIC Series

cCSAus / ATEX / IEC Ex Certified

Ex tb / AEx tb Zone 21 IIIC
T80°C/T100°C/T130°C Db



Enclosure Type 3, 4 & 4X IP66
Report No. 15.70013872

IECEX SIR 14.0053U
SIRA 14ATEX3156U

0518  II 2 G D

Ex e IIC Gb

Ex tb IIIC Db IP66

Service temperature -50°C to +135°C



FEATURES-SPECIFICATIONS

Applications

Panel builders and intergraders building equipment for use in hazardous , corrosive, wet, hose down, dust, dirty , for both hot and cold industrial applications.

- Pulp & Paper Mills
- Breweries
- Electrical Power Plants
- Refineries
- Petrochemical Plants
- Chemical Plants
- Wastewater Treatment
- Grain Facilities
- Marine, Docks, Ports
- Coal Handling
- Off Shore Platforms
- Pumping Stations
- Textile manufacturing
- Food Processing

- Screw covers 316 stainless steel
- Continuous robot welded seams for a hose down tight seal.
- SJIC doors are interchangeable and easily removable.
- Ground/earthing studs in both cover and through wall of the box.
- One piece high temperature closed cell silicone gasket. With superior recovery and re-sealing properties.

- Sturdy 14 gauge box construction helps prevent bending or permanent deflection of the walls when field installing openings.
- Welded one piece mounting flanges top and bottom for strength.
- Openings for glands or conduit

SJIC Enclosures Features—15 Sizes

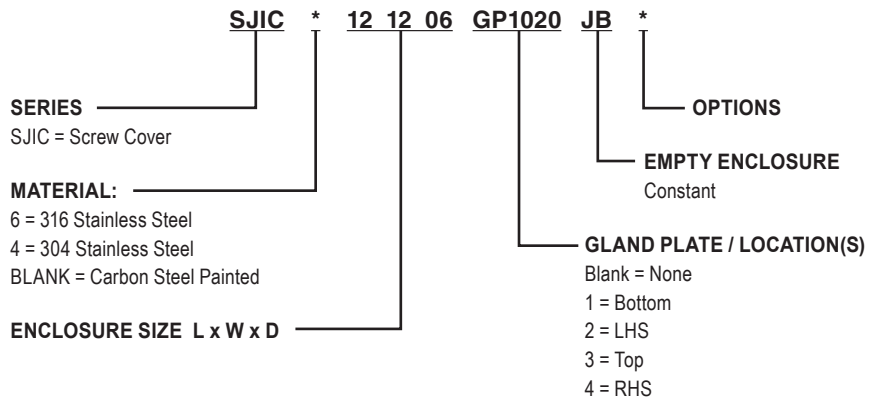



SJIC ENCLOSURES ONLY

TECHNE-TERM[®]

SUFFIX NUMBER	DESCRIPTION
KIT-251	100 amp ground lug
KIT-252	225 amp ground lug
SU3-KDE	Class I Div. 2 Grps A, B, C & D, Type 4X. Ex e IIC Zone 1 IP 66 Drain & breather installed.
SU10-KDE	Class I Div. 2 Grps A, B, C & D, Type 4X. Ex e IIC Zone 1 IP 66 Drain only installed.
DC	Document Wallet (enclosures 10 x 10 and larger only)
SU9	Special paint finish
SU14	Fungus proofing of enclosures

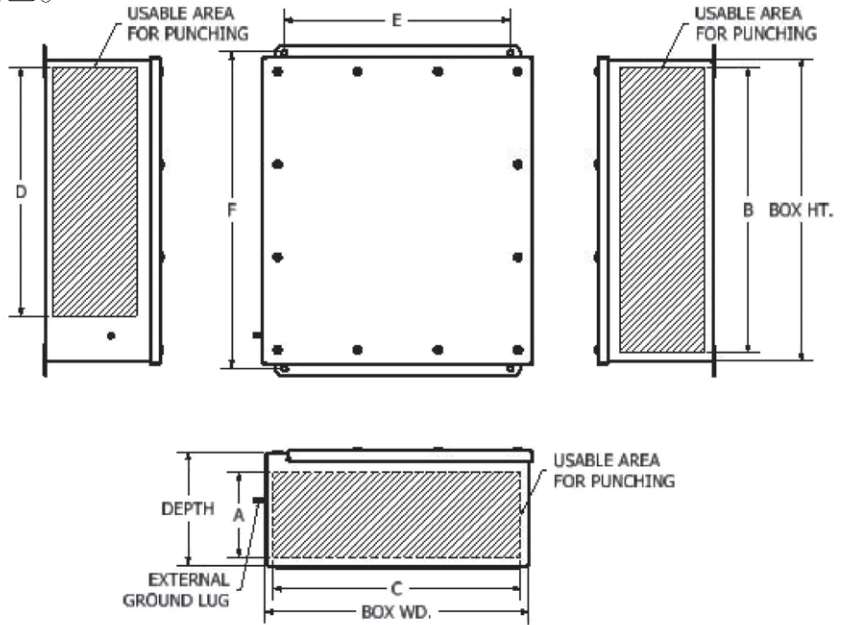

See enclosure modification page for conduit / gland hole sizes and spacing.

CATALOG NUMBER	HEIGHT IN. (MM)	WIDTH	DEPTH	"E"	"F"	"A" BLANK WALL	"B" BLANK WALL	"C" BLANK WALL	"D" BLANK WALL	(W) MAX. POWER	WEIGHT LBS (KG)
SJIC6040404-JB	4 (102)	4 (102)	4 (102)	2.00 (51)	4.75 (121)	2.47(63)	3.13 (79)	3.13 (79)	1.19 (30)	4.1	2.83 (1.3)
SJIC6060404-JB	6 (152)	4 (102)	4 (102)	2.00 (51)	6.75 (171)	2.47(63)	5.13 (130)	3.13 (79)	3.19 (81)	5.2	3.6 (1.6)
SJIC6060604-JB	6 (152)	6 (152)	4 (102)	4.00 (102)	6.75 (171)	2.47(63)	5.13 (130)	5.13 (130)	3.19 (81)	6.1	4.9 (2.2)
SJIC6060606-JB	6 (152)	6 (152)	6 (152)	4.00 (102)	6.75 (171)	4.47 (114)	5.13 (130)	5.13 (130)	3.19 (81)	8.4	5.9 (2.7)
SJIC6080606-JB	8 (203)	6 (152)	6 (152)	4.00 (102)	8.75 (222)	4.47 (114)	7.13 (181)	7.13 (181)	5.19 (132)	10.5	7.5 (3.4)
SJIC6080804-JB	8 (203)	8 (203)	4 (102)	6.00 (152)	8.75 (222)	2.47(63)	7.13 (181)	7.13 (181)	5.19 (132)	8.4	7.9 (3.6)
SJIC6080806-JB	8 (203)	8 (203)	6 (152)	6.00 (152)	8.75 (222)	4.47 (114)	7.13 (181)	7.13 (181)	5.19 (132)	11.4	8.33 (3.8)
SJIC6100804-JB	10 (254)	8 (203)	4 (102)	6.00 (152)	10.75 (273)	2.47(63)	9.13 (232)	7.13 (181)	7.19 (183)	8.4	9.5 (4.4)
SJIC6100806-JB	10 (254)	8 (203)	6 (152)	6.00 (152)	10.75 (273)	4.47 (114)	9.13 (232)	7.13 (181)	7.19 (183)	12.2	10 (4.5)
SJIC6101006-JB	10 (254)	10 (254)	6 (152)	8.00 (203)	10.75 (273)	4.47 (114)	9.13 (232)	9.13 (232)	7.19 (183)	13	11 (5)
SJIC6121005-JB	12 (305)	10 (254)	5 (127)	8.00 (203)	12.75 (324)	3.47 (88)	11.13 (283)	9.13 (232)	9.19 (233)	8.4	12 (5.4)
SJIC6121006-JB	12 (305)	10 (254)	6 (152)	8.00 (203)	12.75 (324)	4.47 (114)	11.13 (283)	9.13 (232)	9.19 (233)	14	13 (5.9)
SJIC6121206-JB	12 (305)	12 (305)	6 (152)	10.00 (254)	12.75 (324)	4.47 (114)	11.13 (283)	11.13 (283)	9.19 (233)	15	15 (6.8)
SJIC6141206-JB	14 (356)	12 (305)	6 (152)	10.00 (254)	14.75 (375)	4.47 (114)	13.13 (334)	11.13 (283)	11.19 (284)	16	16 (7.3)
SJIC6161406-JB	16 (406)	14 (356)	6 (152)	12 (305)	16.75 (425)	4.47 (114)	15.13 (384)	13.13 (334)	13.19 (335)	18	20 (9)

SJIC(H) SERIES INTERNAL MOUNTING PAN

CATALOG NO.	A	B	C	D	THICKNESS
SJIC1010P	7.63 (194)	7.63 (194)	7.00 (178)	7.00 (178)	.13 (3.2)
SJIC1210P	7.63 (194)	9.63 (244)	7.00 (178)	9.00 (228)	.13 (3.2)
SJIC1212P	9.63 (244)	9.63 (244)	9.00 (228)	9.00 (228)	.13 (3.2)
SJIC1412P	9.63 (244)	11.63 (295)	9.00 (228)	11.00 (279)	.13 (3.2)
SJIC1614P	11.63 (295)	13.63 (346)	11.00 (279)	13.00 (330)	.13 (3.2)

All dimension in. (mm)

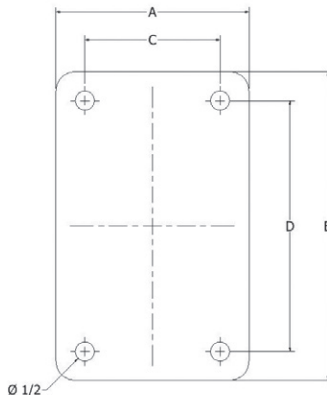

Internal mounting pans are made from high strength aluminum alloy. The aluminum alloy is corrosion resistance and can be drill and tapped in the field for ease of installation of components.

Pans come standard with mounting hardware.

SJIC / SJCH MAXIMUM CONDUIT / GLAND OPENINGS					
W/O GLAND PLATE			W/ GLAND PLATE		
BOX DEPTH	MAX NPT	MAX METRIC	BOX DEPTH	MAX NPT	MAX METRIC
4	1"	M32	4	1/2"	M20
5	1-1/2"	M50	5	1-1/4"	M40
6	3"	M80	6	2"	M63

ENCLOSURES

SJICH SERIES



SJICH ENCLOSURES ONLY • HINGED SCREW COVER

TECHNE-TERM®



SJICH Series

cCSAus / ATEX / IEC Ex Certified

Ex tb / AEx tb Zone 21 IIIC

T80°C/T100°C/T130°C Db

Enclosure Type 3, 4 & 4X IP66

Report No. 15.70013872

IECEX SIR 14.0053U

SIRA 14ATEX3156U

0518 II 2 G D

Ex e IIC Gb

Ex tb IIIC Db IP66

Service temperature -50°C to +135°C



FEATURES-SPECIFICATIONS

Applications

Panel builders and intergraders building equipment for use in hazardous , corrosive, wet, hose down, dust, dirty , for both hot and cold industrial applications.

- Pulp & Paper Mills
- Breweries
- Electrical Power Plants
- Refineries
- Petrochemical Plants
- Chemical Plants
- Wastewater Treatment
- Grain Facilities
- Marine, Docks, Ports
- Coal Handling
- Off Shore Platforms
- Pumping Stations
- Textile manufacturing
- Food Processing

- Screw covers 316 stainless steel
- Continuous robot welded seams for a hose down tight seal.
- SJICH have continuous one piece hinge construction.
- Ground/earthing studs in both cover and through wall of the box.
- One piece high temperature closed cell silicone gasket. With superior recovery and re-sealing properties.

- Sturdy 14 gauge box construction helps prevent bending or permanent deflection of the walls when field installing openings.
- Welded one piece mounting flanges top and bottom for strength.
- Openings for glands or conduit

SJICH Enclosures Features—11 Sizes

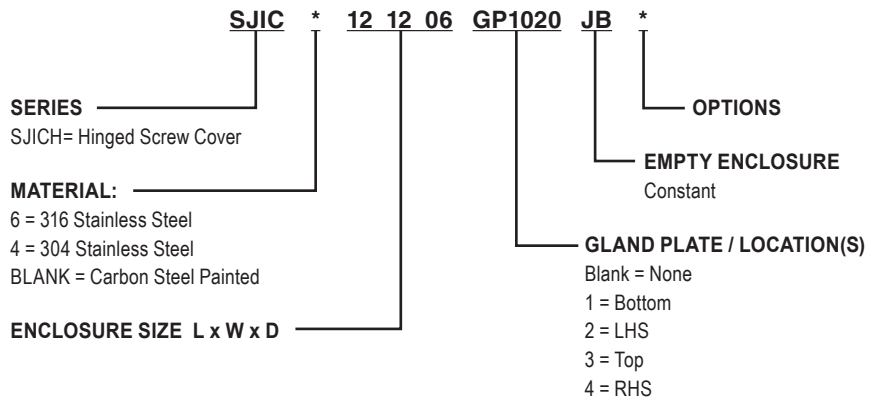



SJICH ENCLOSURES ONLY

TECHNE-TERM[®]

SUFFIX NUMBER	DESCRIPTION
KIT-251	100 amp ground lug
KIT-252	225 amp ground lug
SU3-KDE	Class I Div. 2 Grps A, B, C & D, Type 4X. Ex e IIC Zone 1 IP 66 Drain & breather installed.
SU10-KDE	Class I Div. 2 Grps A, B, C & D, Type 4X. Ex e IIC Zone 1 IP 66 Drain only installed.
DC	Document Wallet (enclosures 10 x 10 and larger only)
SU9	Special paint finish
SU14	Fungus proofing of enclosures

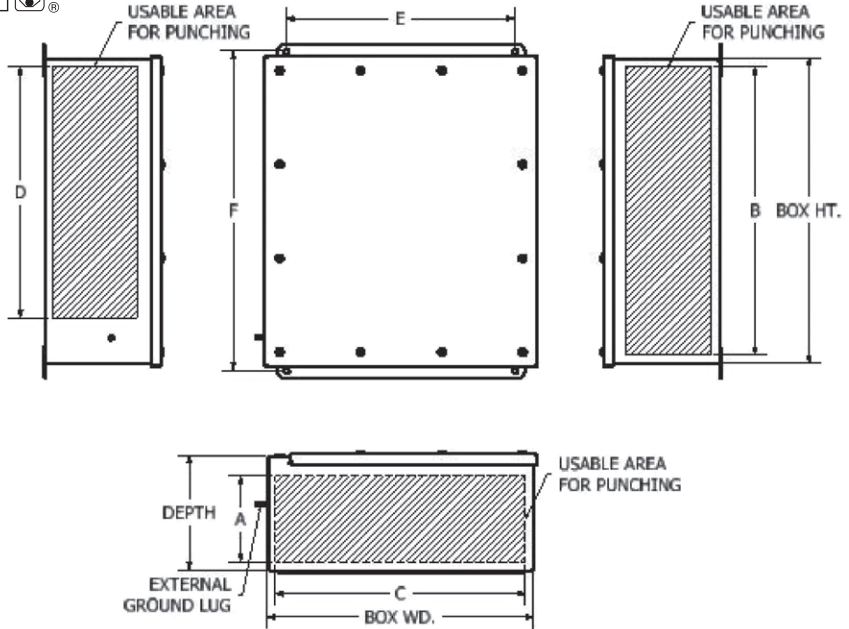

See enclosure modification page for conduit / gland hole sizes and spacing.

CATALOG NUMBER	HEIGHT IN. (MM)	WIDTH	DEPTH	"E"	"F"	"A" BLANK WALL	"B" BLANK WALL	"C" BLANK WALL	"D" BLANK WALL	(W) MAX. POWER	WEIGHT LBS (KG)
SJICH6080606-JB	8 (203)	6 (152)	6 (152)	4.00 (102)	8.75 (222)	4.47 (114)	7.13 (181)	7.13 (181)	5.19 (132)	10.5	7.5 (3.4)
SJICH6080804-JB	8 (203)	8 (203)	4 (102)	6.00 (152)	8.75 (222)	2.47(63)	7.13 (181)	7.13 (181)	5.19 (132)	8.4	7.9 (3.6)
SJICH6080806-JB	8 (203)	8 (203)	6 (152)	6.00 (152)	8.75 (222)	4.47 (114)	7.13 (181)	7.13 (181)	5.19 (132)	11.4	8.33 (3.8)
SJICH6100804-JB	10 (254)	8 (203)	4 (102)	6.00 (152)	10.75 (273)	2.47(63)	9.13 (232)	7.13 (181)	7.19 (183)	8.4	9.5 (4.4)
SJICH6100806-JB	10 (254)	8 (203)	6 (152)	6.00 (152)	10.75 (273)	4.47 (114)	9.13 (232)	7.13 (181)	7.19 (183)	12.2	10 (4.5)
SJICH6101006-JB	10 (254)	10 (254)	6 (152)	8.00 (203)	10.75 (273)	4.47 (114)	9.13 (232)	9.13 (232)	7.19 (183)	13	11 (5)
SJICH6121005-JB	12 (305)	10 (254)	5 (127)	8.00 (203)	12.75 (324)	3.47 (88)	11.13 (283)	9.13 (232)	9.19 (233)	8.4	12 (5.4)
SJICH6121006-JB	12 (305)	10 (254)	6 (152)	8.00 (203)	12.75 (324)	4.47 (114)	11.13 (283)	9.13 (232)	9.19 (233)	14	13 (5.9)
SJICH6121206-JB	12 (305)	12 (305)	6 (152)	10.00 (254)	12.75 (324)	4.47 (114)	11.13 (283)	11.13 (283)	9.19 (233)	15	15 (6.8)
SJICH6141206-JB	14 (356)	12 (305)	6 (152)	10.00 (254)	14.75 (375)	4.47 (114)	13.13 (334)	11.13 (283)	11.19 (284)	16	16 (7.3)
SJICH6161406-JB	16 (406)	14 (356)	6 (152)	12 (305)	16.75 (425)	4.47 (114)	15.13 (384)	13.13 (334)	13.19 (335)	18	20 (9)

SJIC(H) SERIES INTERNAL MOUNTING PAN					
CATALOG NO.	A	B	C	D	THICKNESS
SJIC1010P	7.63 (194)	7.63 (194)	7.00 (178)	7.00 (178)	.13 (3.2)
SJIC1210P	7.63 (194)	9.63 (244)	7.00 (178)	9.00 (228)	.13 (3.2)
SJIC1212P	9.63 (244)	9.63 (244)	9.00 (228)	9.00 (228)	.13 (3.2)
SJIC1412P	9.63 (244)	11.63 (295)	9.00 (228)	11.00 (279)	.13 (3.2)
SJIC1614P	11.63 (295)	13.63 (346)	11.00 (279)	13.00 (330)	.13 (3.2)

All dimension in. (mm)

Internal mounting pans are made from high strength aluminum alloy. The aluminum alloy is corrosion resistance and can be drill and tapped in the field for ease of installation of components.

Pans come standard with mounting hardware.

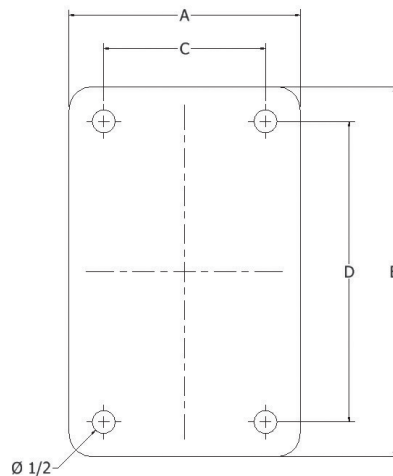

SJIC / SJCH MAXIMUM CONDUIT / GLAND OPENINGS					
W/O GROUND PLATE			W/ GROUND PLATE		
BOX DEPTH	MAX NPT	MAX METRIC	BOX DEPTH	MAX NPT	MAX METRIC
4	1"	M32	4	1/2"	M20
5	1-1/2"	M50	5	1-1/4"	M40
6	3"	M80	6	2"	M63

ENCLOSURES

USF/SJIC/SJICH SERIES



USF / SJIC / SJICH ENCLOSURES



TABLE 1: Minimum distance from edge of box to the center of the conduit / cable entry.

NPT (METRIC)	4"	3-1/2"	3" (M75)	2-1/2" (M63)	2" (M50)	1-1/2" (M40)	1-1/4" (M32)	1" (M25)	3/4" (M20)	1/2" (M16)
IN. (MM)	2-3/4 (70)	2-1/2 (64)	2 (51)	2 (51)	1-5/8 (41)	1-3/8 (35)	1-1/4 (32)	1 (25)	7/8 (22)	3/4 (19)

TABLE 2 Minimum distance from edge of gland plate to the center of the conduit / cable entry.

NPT (METRIC)	4" (M100)	3-1/2" (M80)	3" (M75)	2-1/2" (M63)	2" (M50)	1-1/2" (M40)	1-1/4" (M32)	1" (M25)	3/4" (M20)	1/2" (M16)
IN. (MM)	3-1/4 (83)	3 (76)	2-3/4 (70)	2-1/2 (64)	2-1/8 (54)	1-7/8 (48)	1-3/4 (44)	1-1/2 (38)	1-3/8 (35)	1-1/4 (32)

TABLE 3: NEC / CEC minimum wire bending space from inside wall of the enclosure, North America applications only.

SIZE AWG (MM2)	16 (1.5)	14 (2.5)	12 (4)	10 (6)	8 (10)	6 (16)	4 (25)	2 (35)	1/0 (50)	2/0 (70)	3/0 (95)	4/0 (120)
IN. (MM)	1.5 (38)	1.5 (38)	1.5 (38)	1.5 (38)	1.5 (38)	2 (51)	3 (76)	3.5 (89)	5.5 (140)	6 (152)	6.5 (164)	7 (178)

TABLE 4: Punched hole diameters. For additional sizes not shown please contact the factory.

NPT	4"	3-1/2"	3"	2-1/2"	2"	1-1/2"	1-1/4"	1"	3/4"	1/2"
MAX. HOLE DIA. IN. (MM)	4.53 (115.06)	4.03 (102.36)	3.53 (89.66)	2.905 (73.79)	2.405 (61.08)	1.93 (49.2)	1.69 (42.93)	1.345 (34.16)	1.08 (27.4)	.87 (22.09)
METRIC	M100	M80	M75	M63	M50	M40	M32	M25	M20	M16
MAX. HOLE DIA. MM (IN.)	100.7 (3.94)	80.7 (3.15)	75.7 (2.95)	63.7 (2.48)	50.7 (1.97)	40.7 (1.58)	32.7 (1.26)	25.7 (0.98)	20.7 (0.79)	16.7 (0.63)

TABLE 5: Minimum distance of the center line to center line of the conduit / cable entries.

(NPT) [METRIC]	4 [M100]	3 1/2 [M80]	3 [M75]	2 1/2 [M63]	2 [M50]	1 1/2 [M40]	1 1/4 [M32]	1 [M25]	3/4 [M20]	1/2 [M16]
1/2 [M16]	3 5/8 [92mm]	3 3/8 [86mm]	3 1/8 [80mm]	2 3/4 [70mm]	2 1/2 [64mm]	2 1/4 [58mm]	2 1/8 [54mm]	1 7/8 [48mm]	1 3/4 [45mm]	1 5/8 [41mm]
3/4 [M20]	3 3/4 [96mm]	3 1/2 [89mm]	3 1/4 [83mm]	2 7/8 [74mm]	2 5/8 [68mm]	2 3/8 [60mm]	2 1/4 [58mm]	2 [51mm]	1 7/8 [48mm]	
1 [M25]	3 7/8 [99mm]	3 5/8 [92mm]	3 3/8 [86mm]	3 [77mm]	2 3/4 [70mm]	2 1/2 [64mm]	2 3/8 [60mm]	2 1/8 [54mm]		
1 1/4 [M32]	4 1/8 [105mm]	3 7/8 [99mm]	3 1/2 [89mm]	3 1/4 [83mm]	3 [77mm]	2 3/4 [70mm]	2 1/2 [64mm]			
1 1/2 [M40]	4 1/4 [108mm]	4 [102mm]	3 3/4 [96mm]	3 3/8 [86mm]	3 1/8 [80mm]	2 7/8 [73mm]				
2 [M50]	4 3/4 [121mm]	4 1/2 [115mm]	4 [102mm]	3 5/8 [92mm]	3 3/8 [86mm]					
2 1/2 [M63]	4 7/8 [124mm]	4 5/8 [118mm]	4 1/4 [108mm]	3 7/8 [99mm]						
3 [M75]	5 1/4 [134mm]	5 [127mm]	4 5/8 [118mm]							
3 1/2 [M80]	5 3/4 [147mm]	5 1/2 [140mm]								
4 [M100]	6 1/4 [159mm]									

All dimension in. (mm)