

HUBBELL Power Systems

500 Series - Closed End Cap

By Polycast
Catalog # [DP0500C](#)

The 500 Series Deck Drain is the ideal solution for a wide variety of applications with incidental water run-off. The low profile design is ideally suited for installation in suspended slab applications, such as parking structures, pool decks, and other locations with depth restrictions. DIN Class A - D with Frame E-F

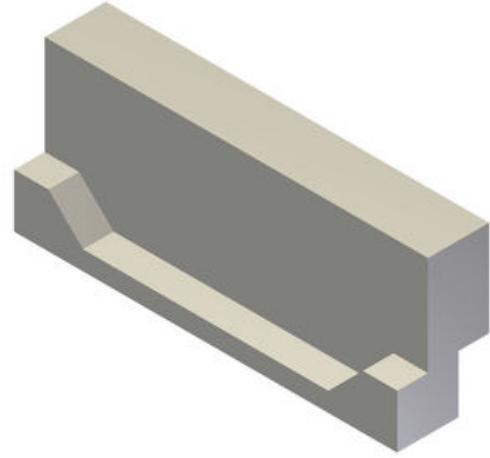

*Representative Image

Features

- The 500 Series is Polycasts shallowest drain
- It is designed to be installed in suspended slab applications, such as parking structures, pool deck areas, and many other thin slab applications
- Available in either polyester for Vinyl Ester polymer concrete

General

Available Options	Available in Vinyl Ester for corrosive or high temperature applications
Color	Gray
Material	Polyester Polymer Concrete
Series	500 Series
Type	Channel Accessories/End Caps

Dimensions

Height	2 in
Length	6 in
Weight	1 lb

Product Assets

[Catalogs - Trench Drains](#)

[Video - Hubbell Power Systems Getting Real About Rust](#)