

Floor Boxes

SystemOne Recessed 10 Gang Floor Box Cover

For Use In Raised Access and Wood Floors

HUBBELL

Features

- 180 degree cover opening to lay flat and reduce tripping hazards
- Two large cable egress doors
- Die cast aluminum cover construction for enhanced durability
- ADA Compliant

Ordering Information

- Compatible with AFB10G55 and AFB10G55CHI
- Rectangular style typical applications: Raised Floors, Wood Floors

Catalog Number	UPC Number	Style	Finish
10GAFBCVRNKC	783585527635	Raised Access / Wood	Nickel Powder Coat

Dimensions	Floor Finish Insert
13-1/16 x 13-3/16 in.	Yes - 6-1/8 x 4-1/2 in.

Specifications

Cover Material	Aluminum
Flange height	0.25 in.
Adjustment Range	0 - 1.0 inch
Load Rating	1500 lbs. (w/ 2x safety factor)

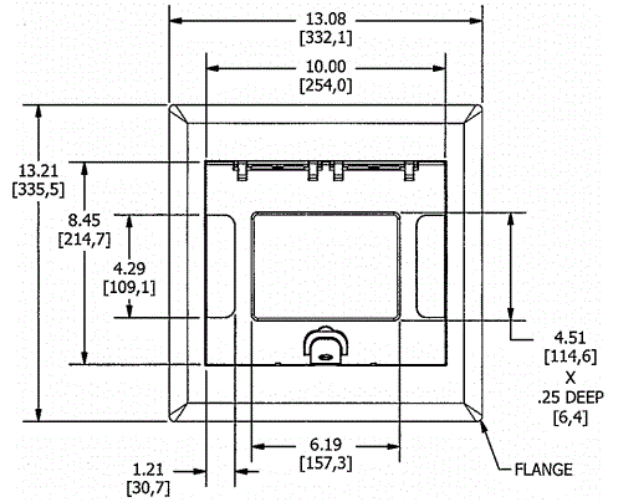

Online Resources

eCatalog