

Floor Boxes
SystemOne Recessed 6 and 10 Gang Floor Box
Cover

HUBBELL

For Use In Concrete Floors

Features

- 180 degree cover opening to lay flat and reduce tripping hazards
- Two large cable egress doors
- Die cast aluminum cover construction for enhanced durability
- Up to 1 in. of upward post pour adjustment
- ADA Compliant

Ordering Information

- Compatible with CFB6G30, CFB6G30CR, CFB10G55 and CFB10G55CR
- Surface style typical applications: Carpet, VCT

Catalog Number	UPC Number	Style	Finish
610GCCVRBKC	783585527284	Surface	Black Powder Coat
Dimensions	Floor Finish Insert		
11-1/2 x 10 in.	Yes - 6-1/8 x 4-1/2 in.		

Specifications

Cover Material	Aluminum
Flange height	0.13 in.
Adjustment Range	0 - 1.0 inch
Load Rating	1500 lbs. (w/ 2x safety factor)

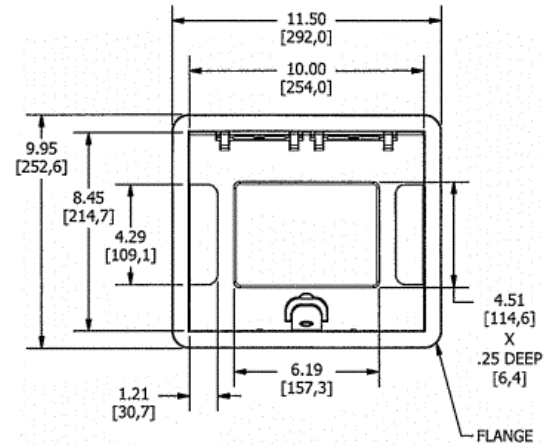
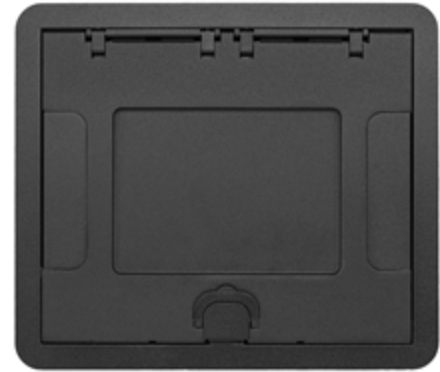

Online Resources

[eCatalog](#)