

**Floor Boxes**  
**SystemOne Recessed 6 and 10 Gang Floor Box**  
**Cover**

# HUBBELL

**For Use In Concrete Floors**

**Features**

- 180 degree cover opening to lay flat and reduce tripping hazards
- Two large cable egress doors
- Die cast aluminum cover construction for enhanced durability
- Up to 1 in. of upward post pour adjustment
- ADA Compliant

**Ordering Information**

- Compatible with CFB6G30, CFB6G30CR, CFB10G55 and CFB10G55CR
- Surface style typical applications: Carpet, VCT

Catalog Number	UPC Number	Style	Finish
610GCCVRBRS	783585446943	Surface	Brass Powder Coat
<b>Dimensions</b>	<b>Floor Finish Insert</b>		
11-1/2 x 10 in.	No		

**Specifications**

Cover Material	Aluminum
Flange height	0.13 in.
Adjustment Range	0 - 1.0 inch
Load Rating	1500 lbs. (w/ 2x safety factor)

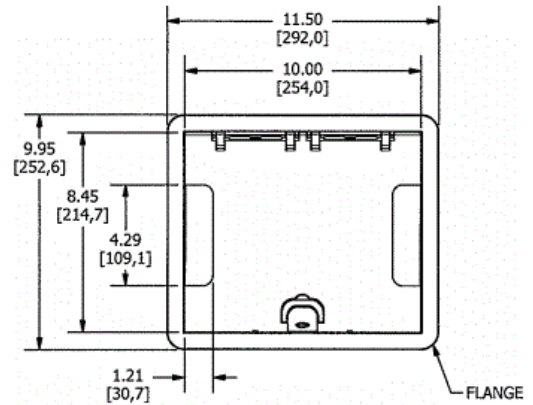
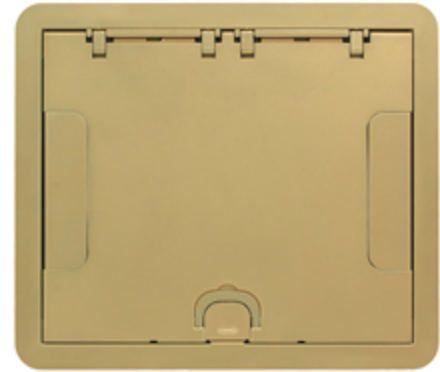

**Online Resources**

[eCatalog](#)