

**Floor Boxes**  
**SystemOne Recessed 6 and 10 Gang Floor Box**  
**Cover**

# HUBBELL

**For Use In Concrete Floors**

**Features**

- 180 degree cover opening to lay flat and reduce tripping hazards
- Two large cable egress doors
- Die cast aluminum cover construction for enhanced durability
- Up to 1 in. of upward post pour adjustment
- ADA Compliant

**Ordering Information**

- Compatible with CFB6G30, CFB6G30CR, CFB10G55 and CFB10G55CR
- Flush style typical applications: Tile, Finished Concrete, Terrazo

<b>Catalog Number</b> 610GTCVRBRS	<b>UPC Number</b> 783585446899	<b>Style</b> Flush	<b>Finish</b> Brass Powder Coat
<b>Dimensions</b> 10-1/2 x 9 in.	<b>Floor Finish Insert</b> No		

**Specifications**

Cover Material	Aluminum
Flange height	0.0 in.
Adjustment Range	0 - 1.0 inch
Load Rating	1500 lbs. (w/ 2x safety factor)

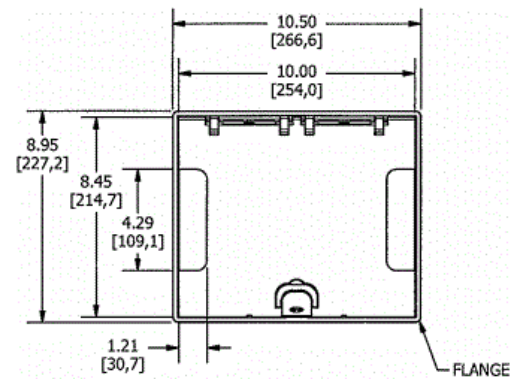
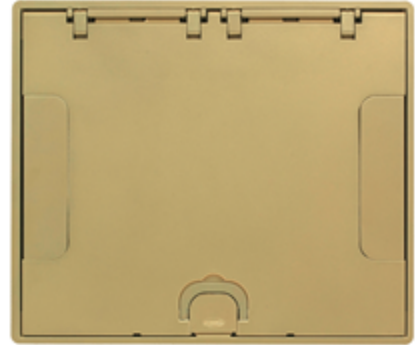

**Online Resources**

eCatalog