

Floor Boxes
SystemOne Recessed 2 Gang Floor Box
For use in Raised Access or Wood Floors

HUBBELL

Features

- 5 in. box depth
- Stamped steel construction
- No knock outs
- Recessed connections or furniture feed applications
- Rectangular covers

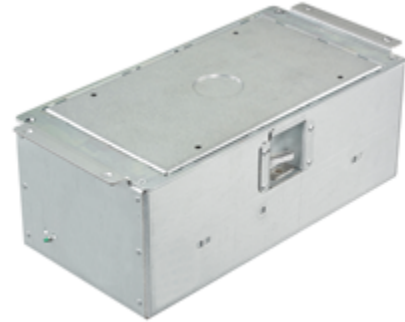

Ordering Information

- Temporary cover for use prior to trim-out
- 6 inch solid conductor ground pigtail in each gang

Catalog Number AFB2G50CHI	UPC Number 783585447216	Cover Series 2GAFBxx / 2GAFBFFxx	Box Type Raised Access
Device Volume 60 cu in.	Depth Behind Mounting Plate 2 3/4 in..	Max. Tile Thickness 2 in.	Min. Tile Thickness 3/4 in.

Specifications

Box Material	16 gauge galvanized steel
Access Cover Material (ordered separately)	Die cast aluminum

Required

Cover
 AFB Style Rectangular Covers (for use with carpet, tile, VCT and [Click here](#) other engineered floors)

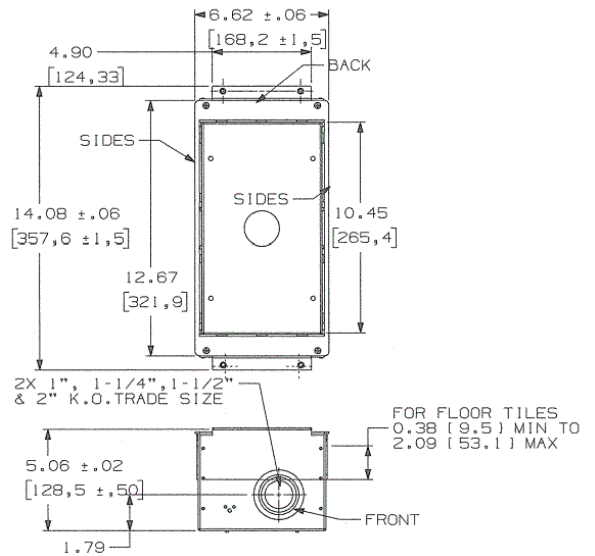

Online Resources

[eCatalog](#)