

**Floor Boxes**  
**SystemOne Recessed 4 Gang Floor Box**  
**For use in Raised Access or Wood Floors**

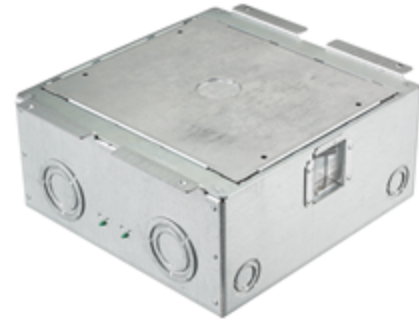

**Features**

- 5 in. box depth
- Stamped steel construction
- 2 in knock outs, one per gang
- Patent pending, labor saving, easy mount device plates
- Rectangular covers



**Ordering Information**

- Temporary cover for use prior to trim-out
- 6 inch solid conductor ground pigtail in each gang

<b>Catalog Number</b> AFB4G50	<b>UPC Number</b> 783585447339	<b>Cover Series</b> 4GAFBxx	<b>Box Type</b> Raised Access
<b>Device Volume</b> 57 1/2 cu in.	<b>Depth Behind Mounting Plate</b> 2 3/4 in..	<b>Max. Tile Thickness</b> 2 in.	<b>Min. Tile Thickness</b> 3/4 in.

**Specifications**

Box Material 16 gauge galvanized steel  
 Access Cover Material (ordered separately) Die cast aluminum

**Required**

Cover  
 AFB Style Rectangular Covers (for use with carpet, tile, VCT and [Click here](#) other engineered floors)

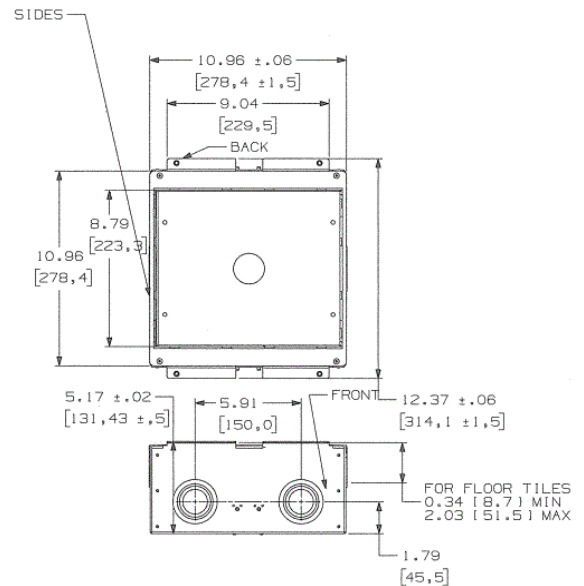

**Online Resources**

[eCatalog](#)

