

# Raceway Metal Raceway Grounding Clamp

# HUBBELL

## Features

- For use with HBL500, HBL700 and HBL750 Series Raceway
- Provides grounding means for 1/2 in. trade size conduit using locknut.

## Ordering Information

Description	Color	UPC Number	Catalog Number
Grounding Clamp	Steel	783585216799	HBL5709GC



## Listings

UL Listed  
CSA Certified

## Specifications

Height	1.04"
Width	1.18"
Length	0.1"

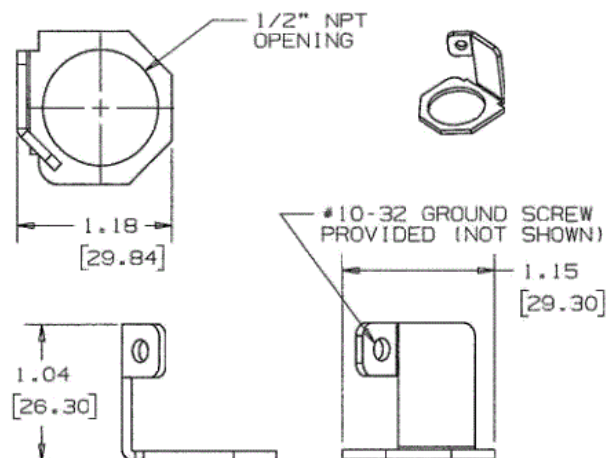

## Online Resources

Customer Use Drawing  
eCatalog  
Installation Instructions