

netSELECT
AV Modules
Fixed 10dB Video Amplifier Module

HUBBELL

Features

- Provides 10dB Video Signal Amplification For Incoming Cable Feeds
- Provides Passive Return to Support Current Digital Cable Systems And Modems
- Pre-mounted Push Pins Snap The Module Quickly Into Place
- Includes RG-59 Cable Jumper To Connect Amplifier To Passive Video Splitter



Ordering Information

Description	Color	CatalogNumber	UPC
120 Volt Powered Fixed Video Amplifier Module	Black	NSOVAMP	883778500336

Listings

UL and cUL Listed
 RoHS Compliant

Specifications

Recommended Wire Gauge	16-14 AWG
------------------------	-----------

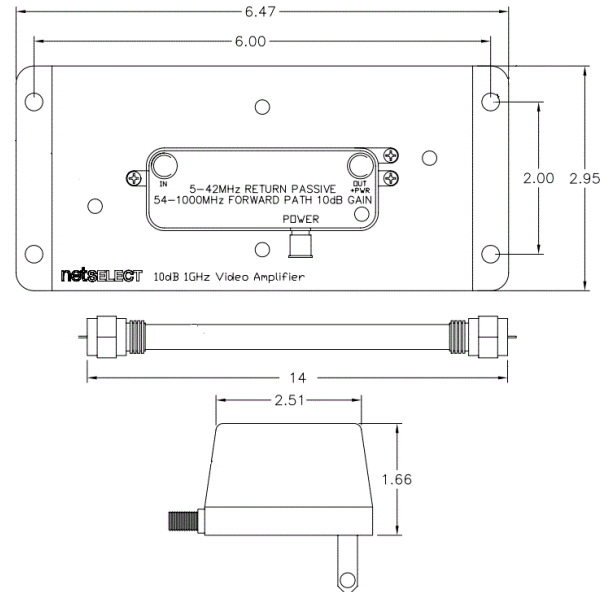

Online Resources

Customer Use Drawing
 eCatalog