

FEATURES

Application

Designed for indoor installation in commercial or industrial applications. Emergency AC power is supplied to lighting fixtures equipped with incandescent, linear fluorescent, compact fluorescent or LED lamps. The lighting load can be installed at a distance of up to 1,000 feet from the LiteGear® central lighting inverter. Observe all required AC conductor sizing requirements. When using LED lamps, consider LED in-rush current in load calculations.

Operation

When normal utility supplied power is interrupted, the LiteGear® Series unit will automatically transfer to emergency mode in less than 2-seconds and begin supplying inverted battery-derived AC power to the load for 90 minutes. The unit is capable of operating normally on, normally off or switched loads. A low voltage battery disconnect circuit will prevent “deep discharge” damage to the battery. The charging circuit will bring the batteries to full recharge within UL time standards. A “brownout” circuit will automatically transfer the unit to emergency power if the utility voltage falls to a pre-determined “low line” limit. 125VA/110W and 250VA/220W versions provide pure sine wave output.

Construction

The LiteGear® enclosure and cover are constructed of heavy-duty, steel with a white powder-coat paint finish.

Compliances

UL 924 (Emergency Lighting)
UL 2043 (Plenum Air Handling Spaces) for LG125T
Life Safety Code (NFPA 101)
National Electrical Code (NFPA 70)
State and Local Code compliant

Warranty

Unit and Electronics: 3 years full*
Spectron® Model Unit and Electronics: 5 years full*
SLA Lead Calcium Battery: 3 years full, 7 years pro-rata

*excludes fuses

Batteries must be connected to an energized charging circuit within 90 days from date of shipment or warranty is void.

LiteGear®



LG250S
250VA Surface
Mount Model



LG125S
125VA Surface
Mount Model



LG125R
125VA Recessed Wall
Mount Model



LG125T
125VA Recessed
Ceiling T-Grid Mount Model

ORDERING GUIDE

LG		Capacity		Mounting		Self-Diagnostics	
Model	Capacity	Mounting	Self-Diagnostics	Model	Capacity	Mounting	Self-Diagnostics
	125 125VA/110W	S Surface Wall	Blank None				
	250 250VA/220W ⁴	R Recessed Wall ¹	I Spectron® Self Testing/Diagnostics ²				
	2 250VA/W ^{3,5}	T Recessed Ceiling T-Grid ¹					

Ordering Notes:

- Only available on 125VA/110W version.
- Only available on 250VA/W version w/ square wave output (LG2SI)
- Only available w/ square wave output and Spectron® Self-Test/Diagnostics (LG2SI)
- Housing (93068300) and batteries (93068259) ship in separate cartons
- Housing (93030104) and batteries (0120935) ship in separate cartons

ACCESSORIES (order separately)

- RTSLG** Remote Test Switch for LG2SI
RTSLP Remote Test Switch for LG125 and LG250S

SPECIFICATIONS

Electronics

Input/Output: 120/120VAC or 277/277VAC, 60 Hz

Input/Output Connections: Terminal block

Operating Temperature Range: 20°C to 30°C (68°F to 86°F)

AC Lockout: Prevents battery discharge following installation when branch circuit AC power is not present.

Low Voltage Battery Disconnect: Protects the battery from damaging "deep discharge" conditions during prolonged power failures.

Brownout Protection: Automatically transfers to emergency power when utility voltage drops to a point that would cause fluorescent lamps to extinguish.

Overload and Short Circuit Protection: AC and DC protection provided by fuses and automatic shut down.

Test Means: Manual "TEST" button.

LED Indicators: LG2SI: "AC-ON/Charging" (green), "Inverter-ON" (amber). LG125/LG250: "AC-ON" (red), "Charging-ON" (green), "Inverter On" (amber)

Battery

Maintenance-free, SLA lead calcium with 10 year rated life.

Optional Spectron® Self-Test/Self Diagnostics

Provides visual indication for battery, charger, transfer circuit and load faults. Conducts automatic 1-minute test every 28 days, a 30-minute test every 6 months, and a 60-minute test once a year. Also includes field selectable 15-minute retransfer delay. Test switch allows for initiation of a 1 minute or a 90-minute system test.

	LG125S	LG125R	LG125T	LG250S	LG2SI
Power Rating (VA - W)	125/110			250/220	250
Power Factor Range	0.44 lead to 0.44 lag				0.8 lead to 0.7 lag
Form and Fit	Wall Mount Surface	Wall Mount Recessed	Ceiling Mount Recessed T-grid	Wall Mount Surface	
Weight (lb) with batteries	42	42	43	60	78
Maximum Input Current (A)	120 VAC: 1.2 A 277 VAC: 0.52 A	120 VAC: 1.2 A 277 VAC: 0.52 A	120 VAC: 1.2 A 277 VAC: 0.52 A	120 VAC: 2.4 A 277 VAC: 1.1 A	120 VAC: 2.5 A 277 VAC: 1.1 A
System DC Voltage	24			48	24
Recharge Time (Hr)	96			96	72

DIMENSIONS

LG125S Wall Mount Surface Model

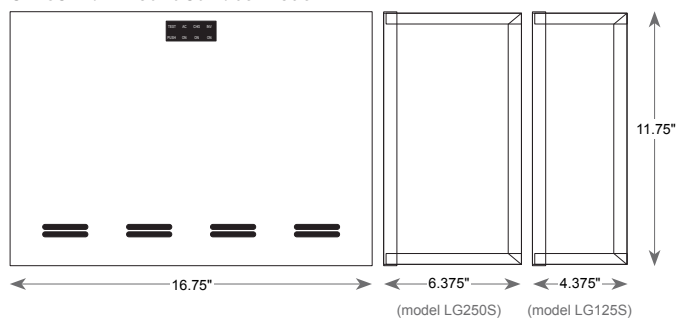

LG125R Recessed Wall Mount Model

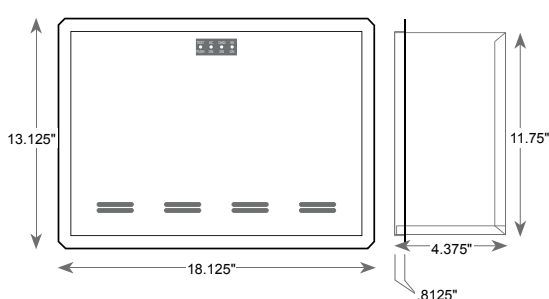

LG125T Recessed Ceiling T-Grid Mount Model

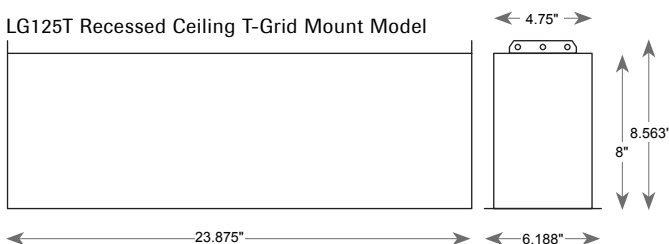

LG2SI Wall Mount Surface Model

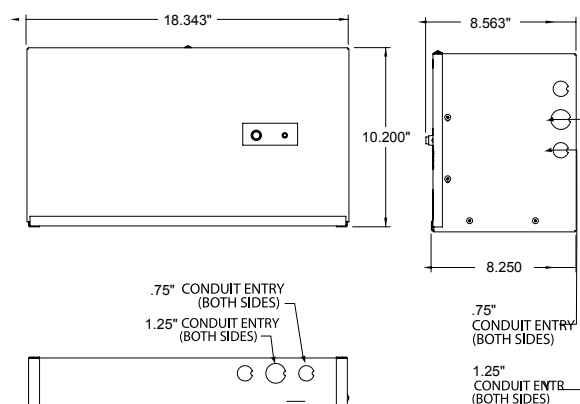

LG250S Wall Mount Surface Model

