

BearTrap™ TU-2TS2

2-way Aluminum Side Break Switches

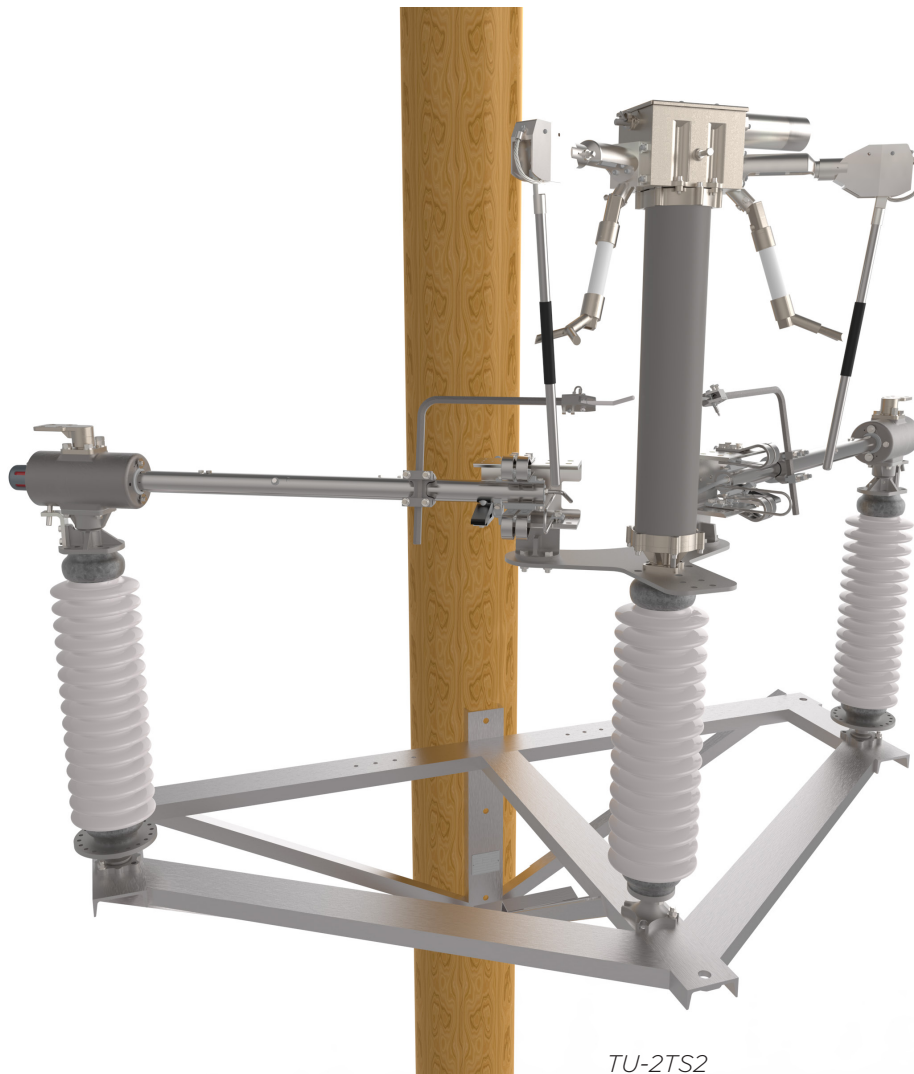

Hubbell has a policy of continuous product improvement. Please visit hubbellpowersystems.com to confirm current design specifications.

Product Information

Overview

The TU-2TS2 2-way switches employ a specially designed, light weight aluminum frame which eliminates the need for pole cross arms or braces. The versatile design makes them ideal for phase-over-phase, the frames are suitable for mounting on wood, steel, concrete, or laminated wood poles. The TU-2TS2 switches help reduce Right-of-Way and real estate issues, as well as associated legal considerations.

Features of the TU-2TS2 Beartrap

- Speed Independent operation—can be closed either fast or slow
- Reverse-loop, silver plated copper jaw contacts— employ the natural repulsion of magnetic fields moving in opposite directions to exert holding forces against the blade edges.
- Components—The 6063-T6 aluminum tubular blade design provides the proper combination of current carrying capacity and rigidity. Silver-plated copper profiles are easily field-replaceable, as are the stationary and moving arcing horns.
- Blade Action—Both the blade and jaw contacts are wiped clean during the closing action to ensure a low re-sistance current transfer. A heavy-duty static blade locking device keeps the blade closed despite temporary faults or surge currents and is designed to pull the blade further into the jaw.
- Anti-Rollover Device—The BearTrap Switch from Turner employs a patented ramp and pin to securely position the blade in the jaw.
- Blade Position Indicator—High visibility stickers provide positive indication of the switch being open or closed. They also have high UV protection and come standard on every switch.
- Current Transfer—There are only two current transfer points in the hinge. The terminal pad is threaded to a stationary contact block creating a spring loaded, silver to silver connection, and the housing transfer current to the blade via a canted coil spring.
- Upgrade-Ability—Ratings can be increased from 600 amps to 1200 amps by adding bolt-on contact fingers to the jaw.
- Main Bearing Assembly And Stationary Insulator Mounting—The main pivot bearing assembly consists of two tapered roller bearings, which are adjusted and factory lubricated.
- Leveling —Leveling screws are provided on the movable and stationary insulator mounting flange for alignment of the insulator stacks.
- Mounting—All frames are designed and constructed for termination of the transmission line a 10,000 pounds working load. Line angles at full tension are limited to +/-5 Degrees of 90 or 180 Degree dead end. If there is an application outside of these parameters, please contact the factory. Generally, 2 and 3 way switches at 115kV and above must be mounted on steel, concrete, or laminated wood poles.

Accessories (Operating Mechanism complete with any of the following)

- Swing Handle (standard)
- Worm Gear
- Motor Operator

Load Break Devices

- TECORupters
 - Full Load Break
 - Loop Split
 - Line Charging
- High Speed Quick Whips

Configurations

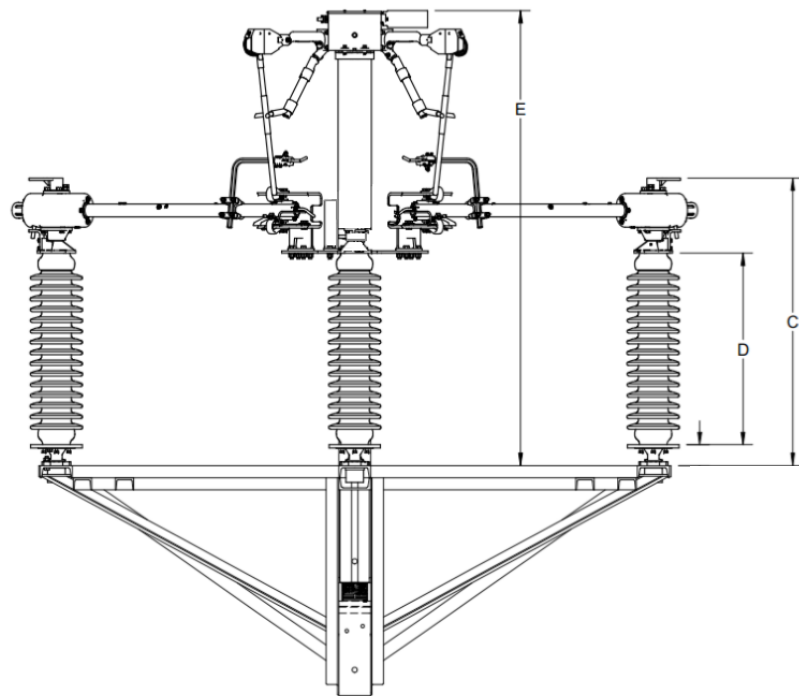
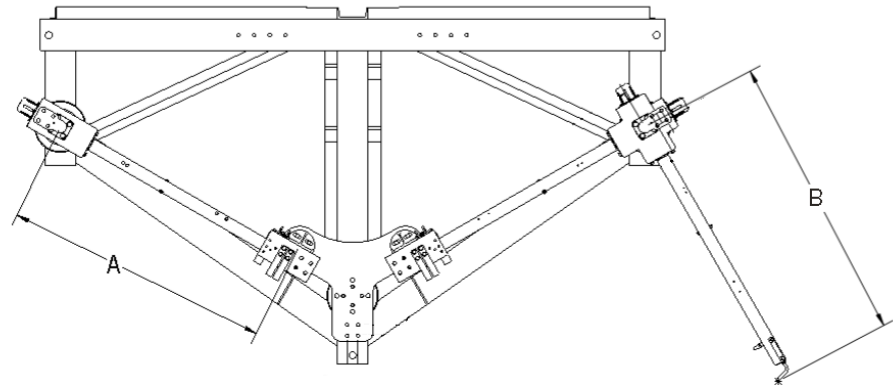
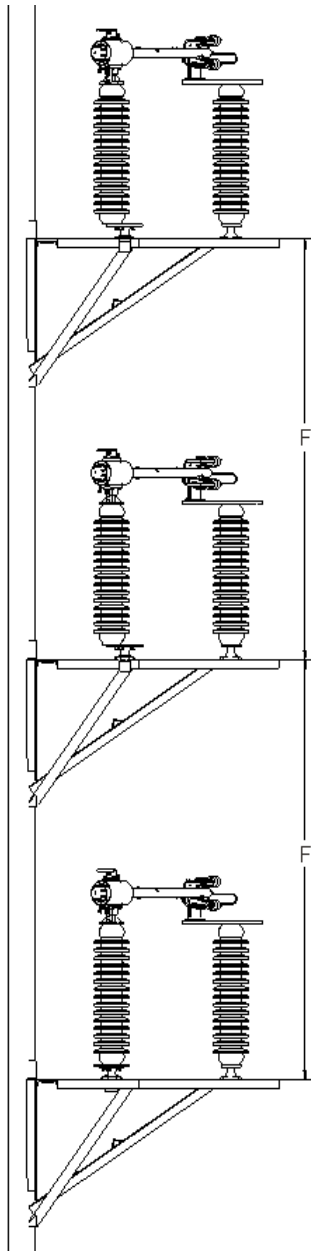

Dimensions (inches)							
kV	A	B	C	D	E	F	F*
38	25	29	33	18	78	57	89
48	30	34	37	22	84	64	96
72	42	46	45	30	98	89	120
123	60	64	62-1/4	45	123-1/2	162	215
145	72	76	71-1/4	54	132-3/4	177	239
170	84	88	79-1/4	62	142-1/4	196	265

F* - with TECO-Ruptor

F* - and F dimensions are minimum required

Numbering Sequence

TU-2TS2	V	A	I	P	TR	LB	OP
	038	06	INC	3		QW	SH
	048	12	NA	5	SEE CHART	VI	WG
	072	20	SIP				MO
	123		DS			LS	
	145					FL	
	170						

Variant Configuration Key

V - Voltage (kV)
A - Current (A)
I - Insulator Ship Method
P - Pivot Size (inches)
TR - Insulator TR
LB - Load Break Device
OP - Operator

Insulator Shipping Methods

INC - With Insulators
NA - Insulators Not Included
SIP - Ship in Place
DS - Direct Ship

Load Break Devices

QW - Quick Whip
VI - Vacuum Interrupter
 • **FL** - Full Load
 • **LS** - Loop Split

OPERATOR

SH - Swing Handle
WG - Worm Gear
MO - Motor Operator

Example

TU-2TS20721INC3216VIFLSH

kV	BIL	TR	Whip Rating (A)	ACCC
38	200	210	18	D06
48	250	214	16	D06
72	350	216	12	D06
123	550	286	10	D06
145	650	288	10	D06
170	750	291	10	D06

Continuous Current (A)	Short Time Rating- 3 Sec (kA)	Peak Withstand Current (kA)
600	25	65
1200	38	99
2000	63	164