

# TU-1AD CUT SHEET

## 1 Way Copper Side Break Switch

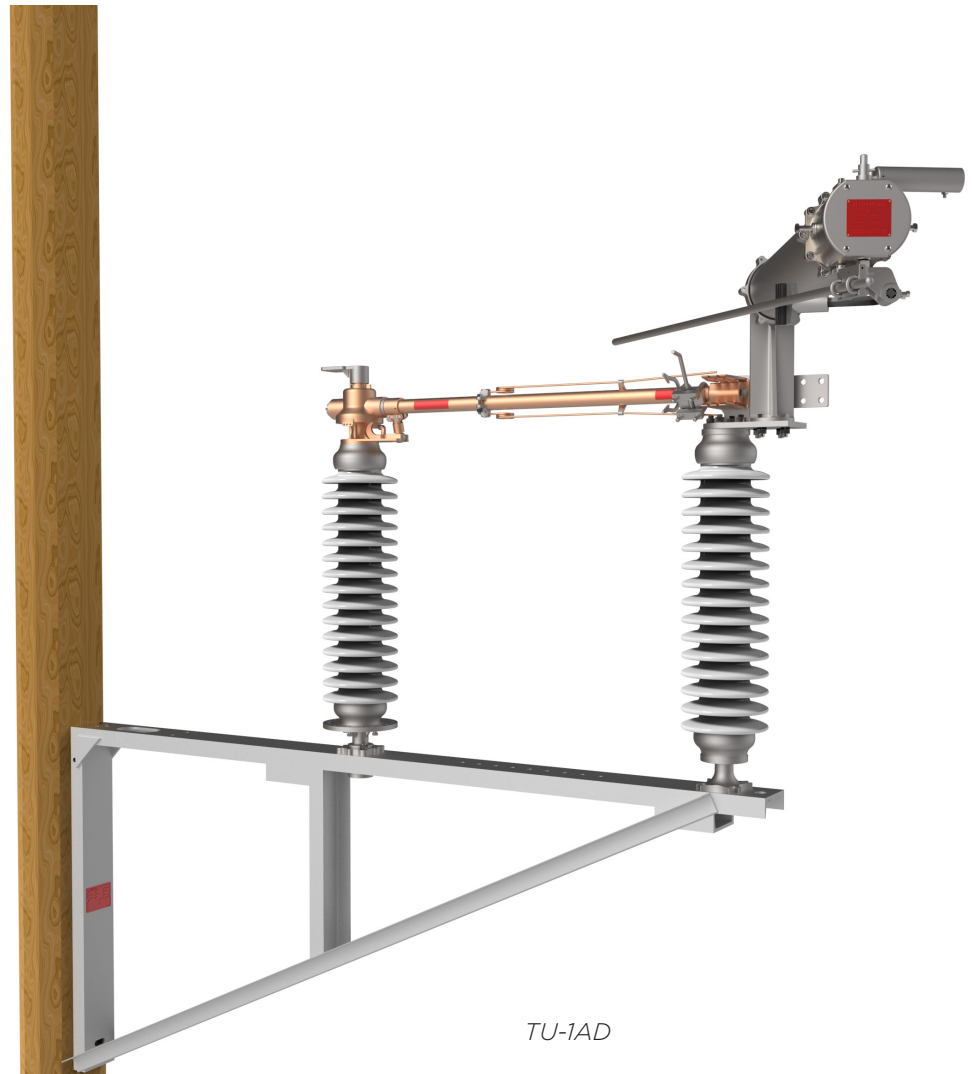

Hubbell has a policy of continuous product improvement. Please visit [hubbellpowersystems.com](http://hubbellpowersystems.com) to confirm current design specifications.

# Product Information

## Overview

The TU-1AD offers the most versatility. The unique frame design, with conductor deadends right on the frame, easily orients to the line angle. Additional positions can be added quickly and with minimal effort. The TU-1AD can also be offered in two, three, and four way mounting configurations for inline or 90 degree takeoffs. Add to this a specially designed “Pole Bracket” and you have maximum switching flexibility.

## Features of the TU-1AD

- Simple Design—switch designed with minimal parts, simplifying the current transfer process
- Copper Design—hard-drawn tubular design provides the proper combination of current carrying capacity and rigidity.
- High Pressure Jaw—jaws are made from Beryllium copper, providing the highest conductivity and strength
- Blade Action—Both the blade and jaw contacts are wiped clean during the closing action to ensure a low resistance current transfer.
- High Speed Double Whips—all switches come with whips standard, breaking limited amounts of line charging current and keeping arcing away from the contact surfaces.
- Blade Lock—A adjustable blade locking device keeps the blade closed despite temporary faults or surge currents.
- Current Transfer—There are only two current transfer points in the hinge. The terminal pad is threaded to a stationary contact block creating a spring loaded, silver to silver connection, and the housing transfer current to the blade via a silver rivets.
- Main Bearing Assembly And Stationary Insulator Mounting—The main pivot bearing assembly consists of two tapered roller bearings, which are adjusted and factory lubricated.
- Leveling —Leveling screws are provided on the movable and stationary insulator mounting flange for alignment of the insulator stacks. Three bolts are also on the jaw end for small final adjustments.
- Mounting—All frames are designed and constructed for termination of the transmission line a 10,000 pounds working load. Line angles at full tension are limited to +/-5 Degrees of 90 or 180 Degree dead end. If there is an application outside of these parameters, please contact the factory.

## Accessories (Operating Mechanism complete with any of the following)

- Swing Handle (standard)
- Motor Operator

## Load Break Devices

- TECORupters™
  - Full Load Break
  - Loop Split
  - Line Charging
- High Speed Quick Whips

# Configurations

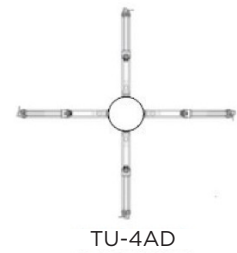
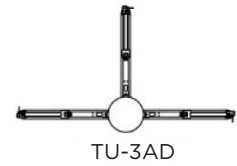
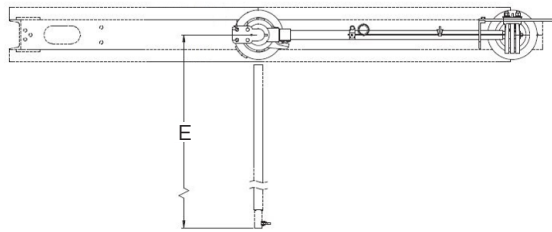
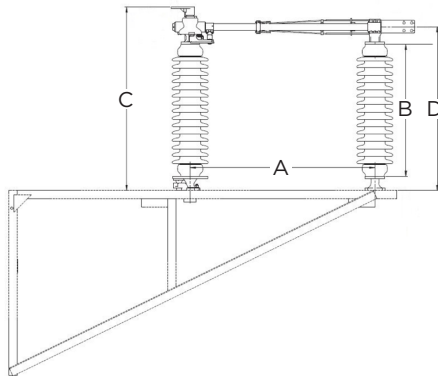
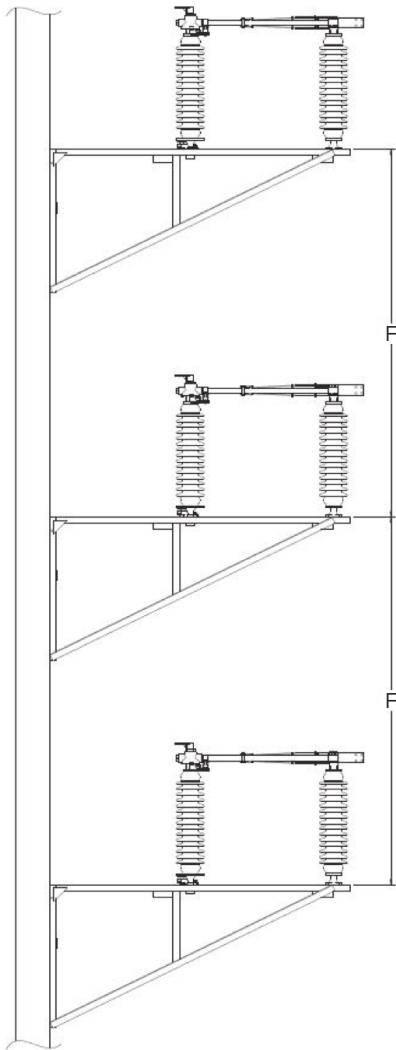

Dimensions (inches)							
kV	A	B	C	D	E	F	F*
38	25	18	29 3/4	25 1/4	25 3/8	72	89
48	30	22	33 3/4	29 1/4	31 3/8	84	96
72	42	30	41 3/4	37 1/4	43 3/8	86	108
123	60	45	59	54 1/2	61 3/8	144	180
145	72	54	68	63 1/2	73 3/8	156	240
170	84	62	79	72 1/4	85 3/8	168	240

F\* - with TECO-Ruptor

F\* - and F dimensions are minimum required

# Numbering Sequence

TU-1AD	V	A	I	P	TR	LB	OP
	038	06	INC	3		QW	SH
	048	12	NA	5	SEE CHART	VI	MO
	072	20	SIP				
	123		DS			LS	
	145					FL	
	170						

## Variant Configuration Key

**V** - Voltage (kV)  
**A** - Current (A)  
**I** - Insulator Ship Method  
**P** - Pivot Size (inches)  
**TR** - Insulator TR  
**LB** - Load Break Device  
**OP** - Operator

## Insulator Shipping Methods

**INC** - With Insulators  
**NA** - Insulators Not Included  
**SIP** - Ship in Place  
**DS** - Direct Ship

## Load Break Devices

**QW** - Quick Whip  
**VI** - Vacuum Interrupter  
 • **FL** - Full Load  
 • **LS** - Loop Split

## OPERATOR

**SH** - Swing Handle  
**MO** - Motor Operator

## Example

TU-1AD07212INC3216VIFLSH

kV	BIL	TR	Whip Rating (A)	ACCC
38	200	210	18	D06
48	250	214	16	D06
72	350	216	12	D06
123	550	286	10	D06
145	650	288	10	D06
170	750	291	10	D06

Continuous Current (A)	Short Time Rating- 3 Sec (kA)	Peak Withstand Current (kA)
600	25	65
1200	38	99
2000	63	164