

FlexMO

Solid State Motor Operator



Hubbell has a policy of continuous product improvement. Please visit hubbelpowersystems.com to confirm current design specifications.

Product Information

The new Turner Solid State Motor Operator (FlexMO) elevates motor operation of high voltage switches to the next level. The FlexMO uses state of the art motor control with one of the widest ranges of capabilities found in any operator on the market today. Designed with the ability to produce up to 20,000 in-lbs. operating torque and operate 90° in 0.5 seconds, the FlexMO is a high performing stock motor. Whether you need a motor operator for a Transmission, Substation, or Distribution switch, the FlexMO could be the last unit you need to purchase

The FlexMO is a completely self-contained electric motor-driven switch operator. With the flexibility to operate switches size from 15kV to 765kV, even switches that require 2 speed closing, the FlexMO is the perfect choice for stocking. The added ability to operate distribution switches means you now have one motor to service all of your existing switches.

The integrated position sensor gives real time updates of the exact vertical operating pipe (VOP) position and provides quick and easy set up of the open and close set points.

The FlexMO offers speed variability control, even during switch operation. The FlexMO can be adjusted to eliminate any switch momentum at the end of the opening/closing cycle, reducing blade oscillations.

With the increasing demand for SCADA ready units, the FlexMO is designed for easy connection. A plug connects your communication device with the standardized controller.

FlexMo Nomenclature

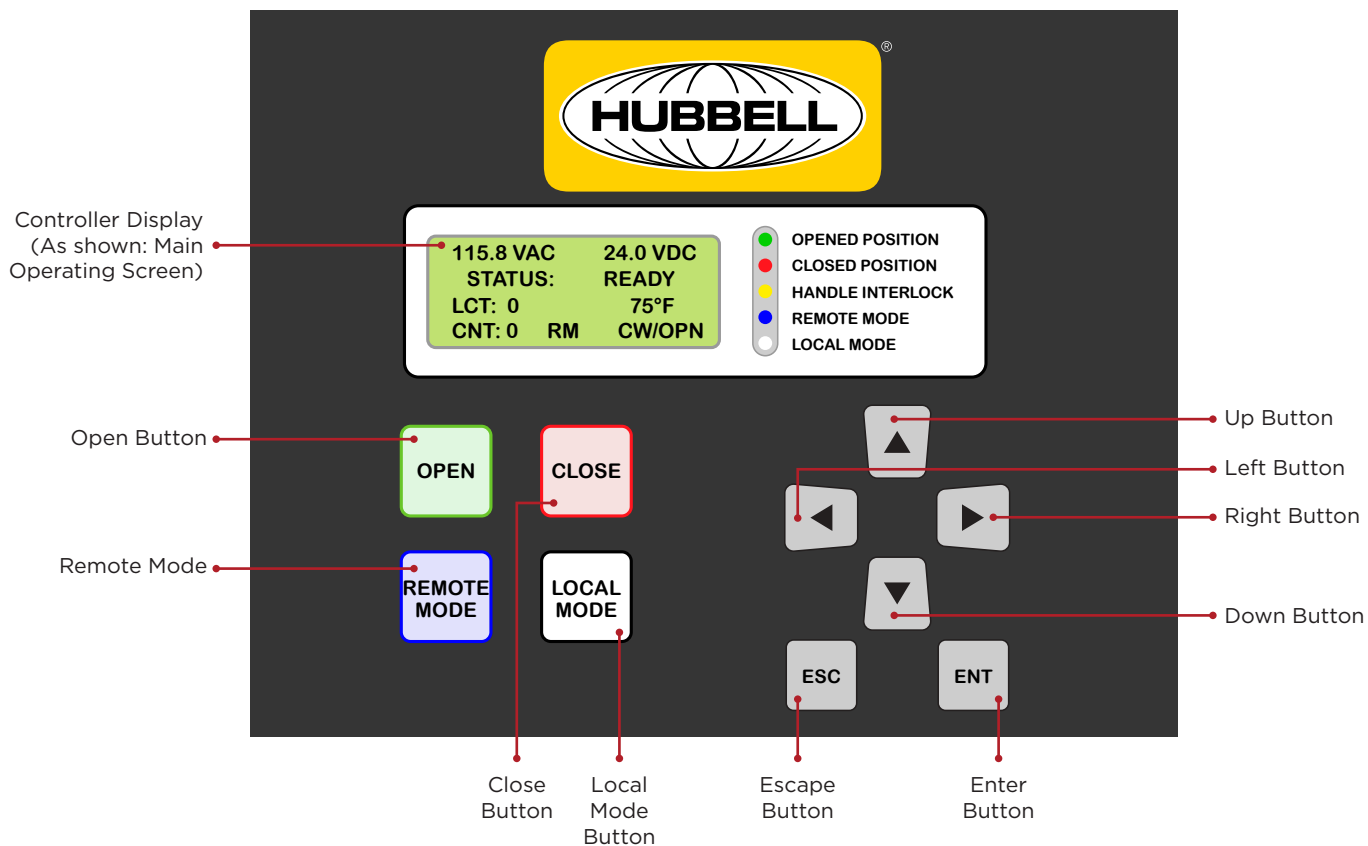

Figure 1. FlexMO motor operator

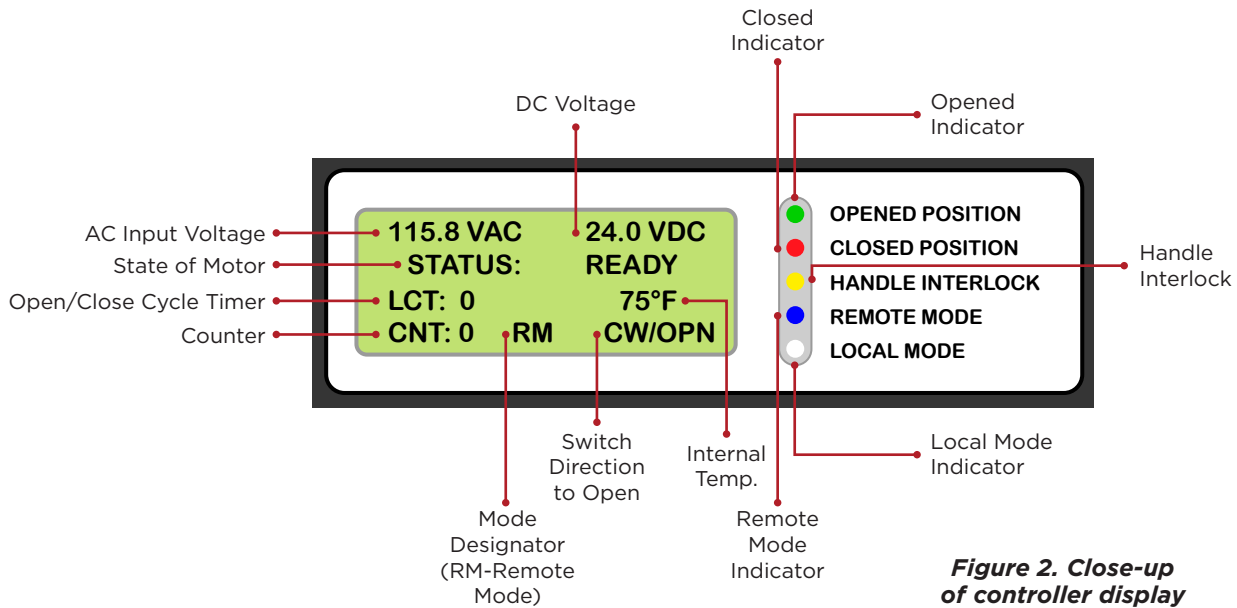

Figure 2. Close-up of controller display

Standard Features

- Variable Speed Control
- Adjustable Auxiliary Relays (up to I2)
- Open/Close Push Button
- Local-Remote Push Buttons
- LED Indicating Lights
- LED Cabinet light
- Fully Adjustable Thermostatically controlled heater (F or C)
- De-coupler for vertical operating pipe
- 3 types of motor overload protection
- Circuit Breaker protection of motor/control and heater
- Dynamic Brake
- Manual hand crank
- Swing Handle
- Motor lockout when hand crank inserted
- Programmable operation delay—open or close
- A/C Alarm (High/Low)
- A/C Auto Switch Open (time delayed)
- A/C Voltage Meter
- D/C Alarm (High/Low)
- D/C Voltage Meter
- Electronic position sensing
- Lockable in Remote "only"
- Lockable in Local "only"
- Software Selectable Switch Rotation
- Solid State Switching
- Removable doors
- Vented Cabinet
- GFI Outlet
- Operations Counter—locked or resettable
- Din Rail Terminal Block

Standard Status Updates

- Open/Close Status
- Circuit Breaker Status
- Local/Remote Status
- Locked Rotor Status
- Loss of A/C Status
- Loss of DC Status
- Door Alarm
- External Interlock Contact
- D/C Operation Lockout - Bad D/C

Optional Features

- Battery Monitoring
- Pre-wired RTU Harness
- SCADA Communication Capability
- Pre-Wired Radio Harness
- Customer specified RTU
- Customer specified Communications
- Battery Backup (24V)

Dimensional Data:

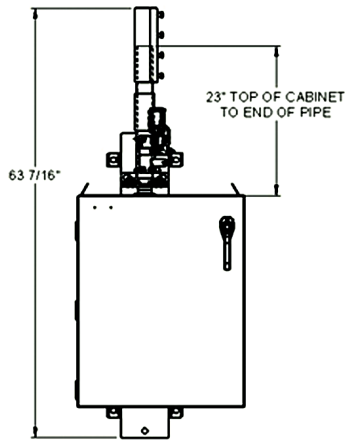

Front

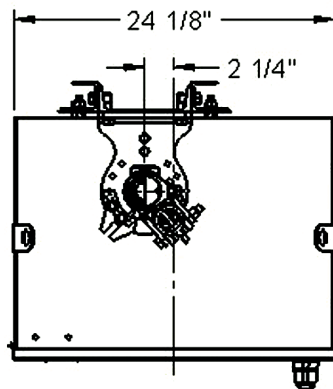

Top

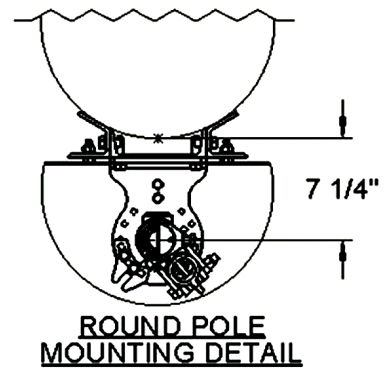

ROUND POLE MOUNTING DETAIL

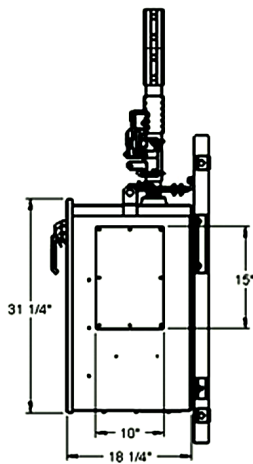

Side

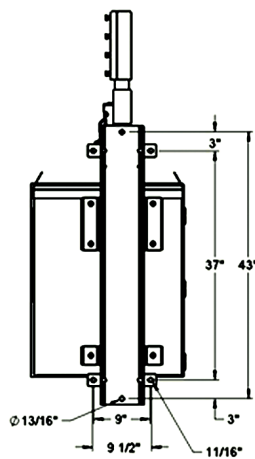

Back

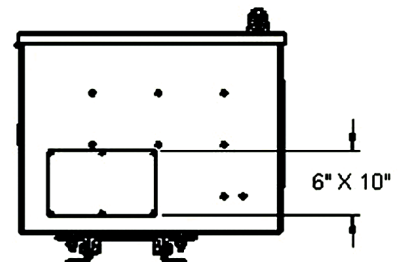

Bottom

Ratings

- Operating Torque: up to 20,000 in-lbs
- Operating Voltages: 24, 48, and 125 VDC, 120 VAC and 240 VAC
- Operating Speed: programmable
- Cabinets: Powder Coated Galvanized Steel (NEMA 3R), Aluminum (NEMA 3R), and Stainless Steel (NEMA 4X)

Hubbell Power Systems, Inc. | hubbellpowersystems.com

HUBBELL
Power Systems, Inc.

©Copyright 2018 Hubbell Incorporated. Because Hubbell has a policy of continuous product improvement, we reserve the right to change design and specifications without notice.



Printed in the U.S.A. | SF_10_189E