

Floor Boxes

SystemOne Recessed 6 and 10 Gang Floor Box Cover

For Use In Concrete Floors

Features

- 180 degree cover opening to lay flat and reduce tripping hazards
- Two large cable egress doors
- Die cast aluminum cover construction for enhanced durability
- Up to 1 in. of upward post pour adjustment
- ADA Compliant

Ordering Information

- Compatible with CFB6G30, CFB6G30CR, CFB10G55 and CFB10G55CR
- Flush style typical applications: Tile, Finished Concrete, Terrazo

Catalog Number	UPC Number	Style	Finish
610GTCVRNK	783585446875	Flush	Nickel Powder Coat
Dimensions	Floor Finish Insert		
10-1/2 x 9 in.	No		

Specifications

Cover Material	Aluminum
Flange height	0.0 in.
Adjustment Range	0 - 1.0 inch
Load Rating	1500 lbs. (w/ 2x safety factor)

HUBBELL

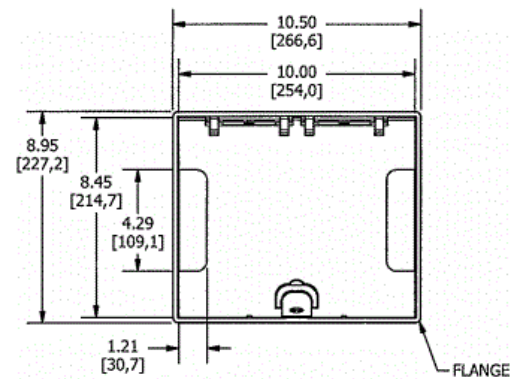

Online Resources

[Customer Use Drawing](#)
[eCatalog](#)
[Installation Instructions](#)

Dimensions in Inches (mm)

Hubbell Wiring Device-Kellems • Hubbell Incorporated (Delaware) • 40 Waterview Drive • Shelton, CT 06484

Phone (800) 288-6000 • Fax (800) 255-1031 • Specifications subject to change without notice.

