

# H-MOSS Controls Adaptive Dual Technology Wall Switch Sensor

# HUBBELL

## Features

- Dual technology sensing combines the individual advantages of passive infrared and ultrasonic detection
- Built in photocell with manual super saver mode for daylight harvesting
- Impact resistant hard lens is standard and color matched to the switch
- 0-10V Dimming with compatible IEC 60929 standard compliant ballasts/LED drivers



## Ordering Information

Description	Color	UPC Number	Catalog Number
DualTech Wall Switch Sensor with Dimming	Ivory	783585427881	ADD200111

## Listings

cULus Listed  
ASHRAE 90.1  
CEC Title 24 Certified

## Specifications

Housing	High-impact injection-molded plastic (UL-94-5V)
Lens	Impact-resistant lens
Mounting Height	42 to 54 Inches Above Floor
Sensing	Passive Infrared and Ultrasonic
Dimming	0-10V, Sink up to 30mA

## Performance

<b>Controls</b>	On/Raise Button & Off/Lower Button
Front Press Switch	Optional Photocell, Adjustable Light Override, 10 to 500 foot candles
Ambient Light	
Timer Time Outs	Auto mode: 4-20 minutes; self-adjusts based on occupancy; fixed mode: 4, 8, 15, and 20 minutes; Test mode: 5 seconds
<b>Electrical</b>	
Ratings	120V AC: 800W Electronic ballast/LED driver 1,000W Magnetic ballast 277V AC: 1,200W Magnetic ballast/ Electronic ballast/LED driver
<b>Environmental</b>	
Operating Temperature	Indoor use only, operating temperature: 32° to 104°F (0° to 40°C), relative humidity (non-condensing): 0% to 95%

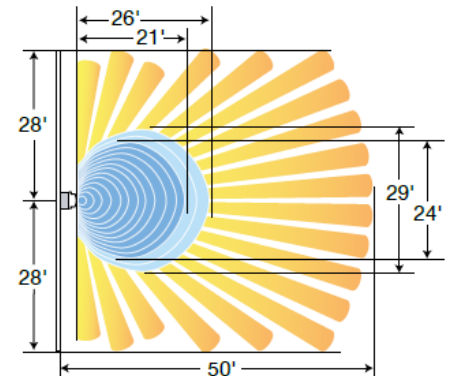
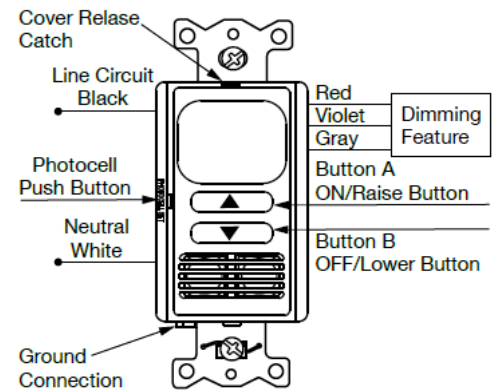

Dimensions in Inches (mm)

Hubbell Wiring Device-Kellems • Hubbell Incorporated (Delaware) • 40 Waterview Drive • Shelton, CT 06484

Phone (800) 288-6000 • Fax (800) 255-1031 • Specifications subject to change without notice.

