

Floor Boxes
 Flush Rectangular Cast Iron
 Concrete Floor Boxes



Features

- Corrosion resistant for on-grade applications
- Gray Powder Coat Paint
- Adjustable Before and After Concrete Pour



Ordering Information

Description	Collar Material	UPC Number	Catalog Number
One Gang Floor Box	Brass	783585100609	B2437

Listings

UL Listed File Number E92074
 CSA File Number LR18416

Specifications

Style	Cast Iron
Capacity Per Gang	30.0 cu. in. (491.7 cm ³)
Threaded NPT Hubs	(4) 3/4"

Performance

Installation Information	
Min. Depth of Pour	3.00" (76.2)
Post Pour Adjustment	0.38"

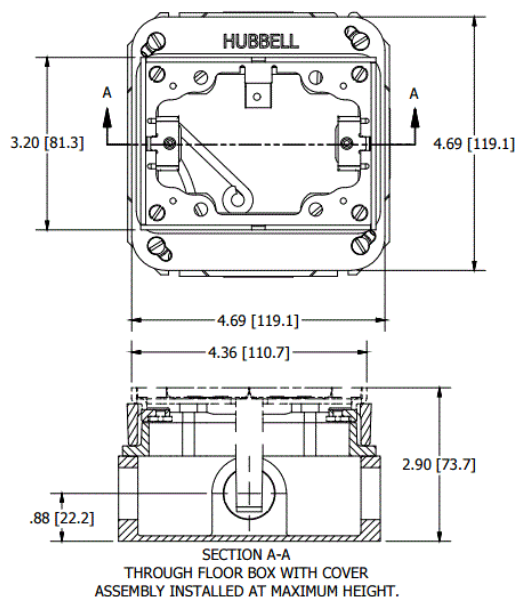

Complementary Products

Replacement Collar	C2400
Replacement Brass Cover Flange	S5017A

Online Resources

Customer Use Drawing
 eCatalog
 Installation Instructions

Dimensions in Inches (mm)

Hubbell Wiring Device-Kellems • Hubbell Incorporated (Delaware) • 40 Waterview Drive • Shelton, CT 06484

Phone (800) 288-6000 • Fax (800) 255-1031 • Specifications subject to change without notice.

