

Ground Fault Products
 Portable GFCI Line Cords
 Commercial Grade, Automatic and Manual
 Set

HUBBELL

Features

- High impact UV stabilized housing for long life
- All-glass circuit board provides moisture immunity
- Watertight GFCI housing for use in harsh environments



Ordering Information

Description	Length	UPC	Catalog Number
15A GFCI in line GFCI, triple tap, automatic set, 15A 120V AC	2' (60.9 cm), 5-15 single tap, automatic set, 12/3 SJTW	783585692081	GFPI15125TRIA

Listings

UL Listed
 CSA Certified

Specifications

Housing	Polycarbonate
---------	---------------

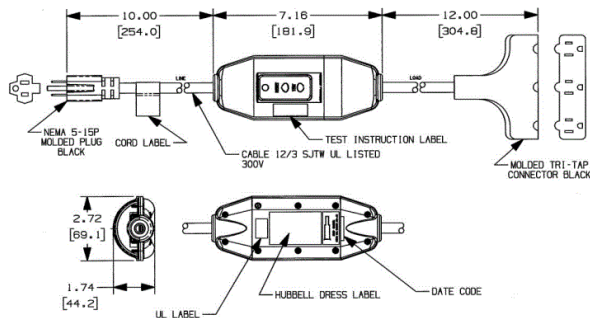

Online Resources

Customer Use Drawing
 eCatalog
 Installation Instructions

Dimensions in Inches (mm)

Hubbell Wiring Device-Kellems • Hubbell Incorporated (Delaware) • 40 Waterview Drive • Shelton, CT 06484

Phone (800) 288-6000 • Fax (800) 255-1031 • Specifications subject to change without notice.

