

Non-NEMA Twist-Lock® Devices
20A Accessories
Weatherproof Boot

HUBBELL

Features

- Weather protective covering
- Durable thermoplastic elastomer material
- Ribbed design provides a secure grip



Ordering Information

Description	Device Color	UPC	Catalog Number
Seal-Tite® triple seal boot for Variload® connector bodies	Black	783585809236	HBL6028

Specifications

Material	Thermoplastic Elastomer
----------	-------------------------

Performance

Environmental

Moisture Resistance	IP55
Operating Temperatures	Maximum Continuous 75°C; Minimum -40°C (w/o impact)

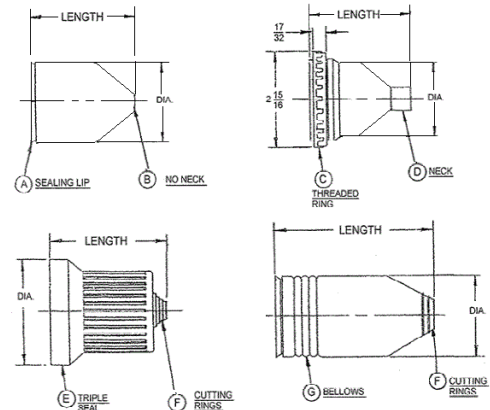

CATALOG NO.	DIA.	LENGTH	COLOR	DETAILS
HBL60CM23	1 27/32	2 23/32	YELLOW	A-F
HBL60CM24	2 19/32	3 29/32	YELLOW	E-F
HBL60CM31V	2 5/16	3 15/32	YELLOW	A-F
HBL60CM32	3 1/32	4 13/16	YELLOW	E-F
HBL60CM32V	3 1/32	4 13/16	YELLOW	E-F
HBL60CM33V	3 1/8	2 5/16	YELLOW	C-F

CATALOG NO.	DIA.	LENGTH	COLOR	DETAILS
HBL7440V	1 3/8	1 7/8	BLACK	E-D
PH7440	1 3/8	1 7/8	YELLOW	A-B
PH7499	1 3/8	2 3/8	YELLOW	A-B
HBL77CM15	2 5/8	5 3/8	YELLOW	C-F-G
HBL77CM16	2 5/8	5 5/16	YELLOW	A-F-G
HBL77CM17	2 5/8	6 5/16	YELLOW	A-F-G

Accessories

Connector Accommodation	Variload Twist-Lock®
-------------------------	----------------------

Resources

Customer Use Drawing
eCatalog

Dimensions in Inches (mm)

Hubbell Wiring Device-Kellems • Hubbell Incorporated (Delaware) • 40 Waterview Drive • Shelton, CT 06484

Phone (800) 288-6000 • Fax (800) 255-1031 • Specifications subject to change without notice.

