

# Non-NEMA Twist-Lock® Devices 10A, 250V, 15A, 125V, 2 Pole, 3 Wire Grounding Stainless Steel Flanged Receptacle

# HUBBELL

## Features

- Heat resistant thermoset construction
- Stainless steel casing
- #8-32 terminal screws
- Mounting screws included

## Ordering Information

Description	Device Color	UPC	Catalog Number
Stainless steel casing, brown phenolic	Brown/Stainless	783585237671	HBL7557G

## Listings

Listed to UL 498  
Fed. Spec. W-C-596  
Certified to CSA C22.2 No.42

## Specifications

Flange	Stainless steel
Blades	Brass
Terminal Screws	Brass
Mounting Screw	Nickel plated brass

## Performance

### Electrical

Current Interrupting	Certified for current interrupting at full rated current
Dielectric Voltage	Withstands 2,000V minimum

### Mechanical

Terminal Accommodation #18 AWG -#10 AWG solid or stranded copper wire only.

Terminal Identification Terminals identified in accordance with UL 498

### Environmental

Flammability	HB or better per UL94/CSA 22.2 No.0.17
Moisture Resistance	IP20 Suitability
Operating Temperatures	Maximum Continuous 75°C; Minimum -40°C (w/o impact)

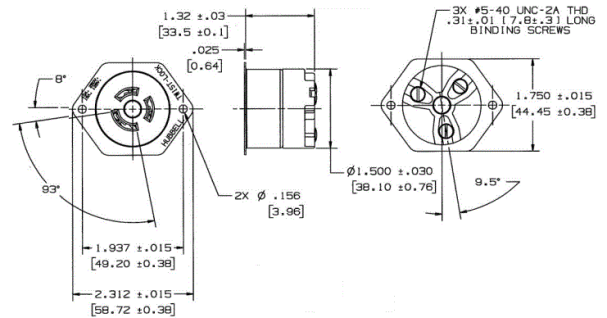

## Accessories

Plug	HBL7567C
------	----------

## Resources

Customer Use Drawing  
eCatalog

Dimensions in Inches (mm)

Hubbell Wiring Device-Kellems • Hubbell Incorporated (Delaware) • 40 Waterview Drive • Shelton, CT 06484

Phone (800) 288-6000 • Fax (800) 255-1031 • Specifications subject to change without notice.

