

Straight Blade Devices

15A, 125V, 2 Pole, 3 Wire Grounding

HBL[®] Extra Heavy Duty MAX Hospital Grade Duplex Receptacle

HUBBELL

Features

- Slender/compact design
- Impact-resistant finder groove face
- Triple wipe contacts
- Entire face illuminated by two LEDs

Ordering Information

Description	Device Color	UPC Number	Catalog Number
Illuminated face, back and side wired.	Red	783585016467	HBL8200ILR

Listings

CSA Certified
UL Listed to UL498 File No. E2186
Fed. Spec. W-C-596
NEMA[®] WD-6 Compliant

Specifications

Face	Polycarbonate
Base	PBT
By-Pass Power Contacts	.036". (.9) Nickel plated brass
Ground Contacts	.031 in. (.8) Brass
Clamp	Nickel plated steel
Terminal Screws	Brass
Mounting Strap	Brass
Automatic Self-grounding Clip	.050 in. (1.3) Nickel plated brass
Mounting Screws	Stainless Steel

Performance

Electrical	
Current Interrupting	Certified for current interrupting at full rated current
Dielectric Voltage	Withstands 2,000V minimum

Mechanical	
Product Identification	Ratings are a permanent part of the device
Terminal Accommodation	#14-#10 AWG stranded or solid copper wire only
Terminal Identification	Terminals identified in accordance with UL 498 and CSA

Environmental	
Flammability	UL 94V-2
Operating Temperatures	Maximum continuous 75°C; minimum -40°C (w/o impact)



15A 125V AC
NEMA 5-15R
UL CSA
0.5 HP

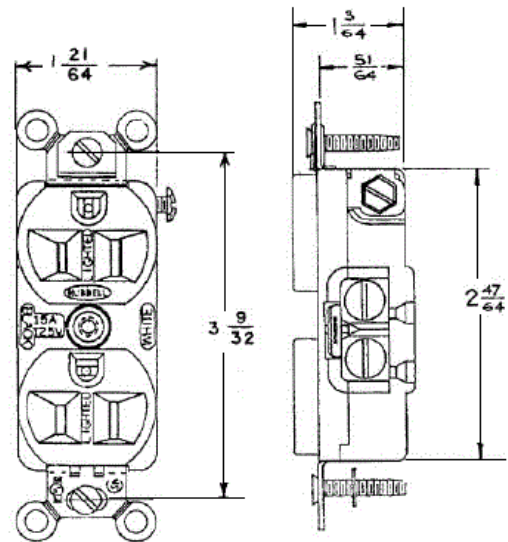

Complementary Products

Wallplate or Weatherproof Cover

Duplex Opening

Online Resources

Customer Sales Drawings
eCatalog
Installation Instructions

Dimensions in Inches (mm)

Hubbell Wiring Device-Kellems • Hubbell Incorporated (Delaware) • 40 Waterview Drive • Shelton, CT 06484

Phone (800) 288-6000 • Fax (800) 255-1031 • Specifications subject to change without notice.

