

Raceway
Aluminum Raceway
HBLALU2000 Series Ground Adapter
(Plated)

HUBBELL

Features

- For connection of equipment grounding conductor to provide an additional ground to raceway.
- Screws included.

Ordering Information

Description	Material	UPC Number	Catalog Number
Ground Adapter (Plated)	Galvanized Steel	783585110615	HBLALU2009

Listings

UL Listed
CSA Certified

Specifications

Height	0.2"
Width	2.35"
Length	1.18"

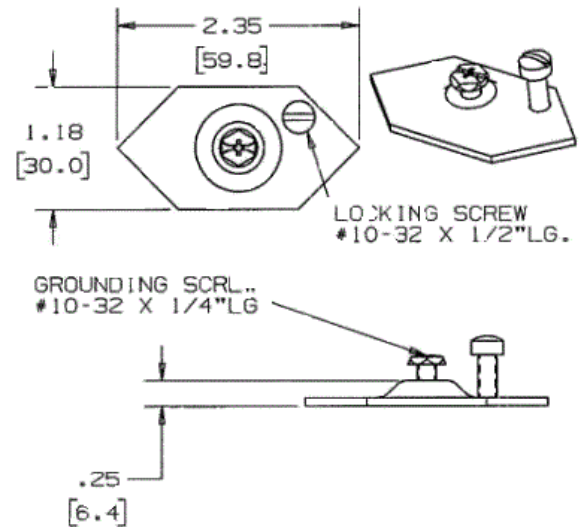

Online Resources

Customer Use Drawing
eCatalog
Installation Instructions

Dimensions in Inches (mm)

Hubbell Wiring Device-Kellems • Hubbell Incorporated (Delaware) • 40 Waterview Drive • Shelton, CT 06484

Phone (800) 288-6000 • Fax (800) 255-1031 • Specifications subject to change without notice.

