

Raceway
Aluminum Raceway
HBLALU4800 Series Two Channel Inverted
Internal Elbow

HUBBELL

Features

- For connecting a vertical run of HBLALU4800 with a horizontal run with its cover facing up.
- HBLALU5701 couplings included.
- See page R-44 for cover plates.



Ordering Information

| Description | Material | UPC Number | Catalog Number |
|-------------------------|-------------------|--------------|----------------|
| Inverted Internal Elbow | Anodized Aluminum | 783585218816 | HBLALU4817N |

Listings

UL Listed
 CSA Certified

Specifications

| | |
|--------|-------|
| Height | 2.10" |
| Width | 6.00" |
| Length | 5.98" |

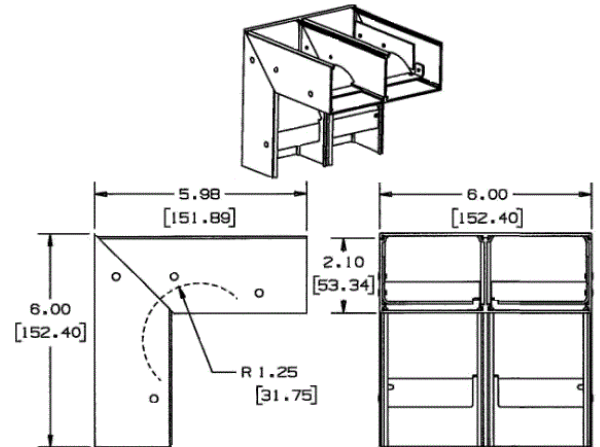

Online Resources

Customer Use Drawing
 eCatalog
 Installation Instructions

Dimensions in Inches (mm)

Hubbell Wiring Device-Kellems • Hubbell Incorporated (Delaware) • 40 Waterview Drive • Shelton, CT 06484

Phone (800) 288-6000 • Fax (800) 255-1031 • Specifications subject to change without notice.

