

Raceway
Aluminum Raceway
HBLALU7620 Series Grounding Adapter

HUBBELL

Features

- For connection of equipment grounding. #10-32 Locking screws included.

Ordering Information

Description	Material	UPC Number	Catalog Number
Grounding Adapter	Galvanized Steel	783585110820	HBLALU5709

Listings

UL Listed
CSA Certified

Specifications

Height	3.37"
Width	2.00"
Length	0.20"

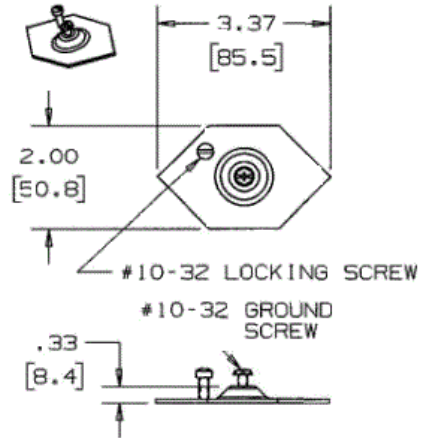

Online Resources

Customer Use Drawing
eCatalog
Installation Instructions

Dimensions in Inches (mm)

Hubbell Wiring Device-Kellems • Hubbell Incorporated (Delaware) • 40 Waterview Drive • Shelton, CT 06484

Phone (800) 288-6000 • Fax (800) 255-1031 • Specifications subject to change without notice.

