

High/Low Bay Sensors with 0-10V Dimming Capability

Features

- Digital passive infrared sensor. Low profile design, no minimum load
- Two (2) Built-in photocell for daylight harvesting
- 208/240V AC, 1 double pole relay
- Supports mounting heights up to 45 ft for high bay configurations and between 8-16 ft for low bay configurations

Ordering Information

Description	Device Color	UPC Number	Catalog Number
High/Low bay PIR sensor, 1 double pole relay with photocell	White	783585564777	HBS28D

Listings

cULus Listed
Meets ASHRAE 90.1
CEC Title 24 Compliant

Specifications

Casing	High-impact injection-molded thermoplastic
Size	4.0" Diameter x 1.5" height
Weight	7 oz.
Mounting	Mounts directly to the end of a fixture

Performance

Electrical	
Current Sinking Capacity	30mA
Lighting Load Capacity	208/240V AC: 0-1200 watts ballast, 5A LED driver
User Interface	12-pin DIP switch

Environment

Operating Location	Indoor use only
Operating temperature	32°F to 149°F (-40°C to 65°C)
Relative humidity	0% to 95%

Timer time-outs

Primary	8-second test mode 4, 8, 16 and 30 minutes.
Secondary	Disabled, 30, 60 and 90 minutes. Available on dual relay versions only.

HUBBELL

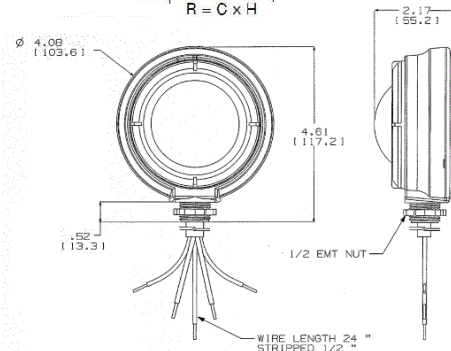
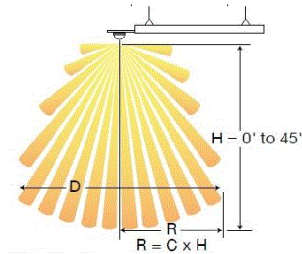

Complementary Products

Extension Mounting Adapter	HMHBSA
High bay replacement lens, 360°	HBRL360
Low bay replacement lens, 360°	LBRL360

Online Resources

Customer Use Drawing
eCatalog
Installation Instructions