

netSELECT

Network Enclosures

14-Inch Network Enclosure

Features

- Horizontal And Vertical Module Mounting Holes For Maximum Flexibility
- Horizontal And Vertical Module Mounting Holes For Maximum Flexibility
- Recommended Module Unit Capacity: 5

Ordering Information

Description	Color	UPC Number	CatalogNumber
14-Inch Network Enclosure, With Panel Cover	White	883778503122	NSOBOX14BC

Listings

UL and cUL Listed
RoHS Compliant

Specifications

Material	18 Gauge Steel
Finish	White, Powder Coat
Dimensions in (mm) (H x W x D)	15.55 (395) x 15.65 (398) x 4.08 (104)
Module Unit Capacity	5
Includes	Mounting Hardware Kit and Wiring Label

Complementary Products

Power Kit	NSOKPTR
Surge Protected Power Kit	NSOKPS

Online Resources

Customer Use Drawing
eCatalog

HUBBELL

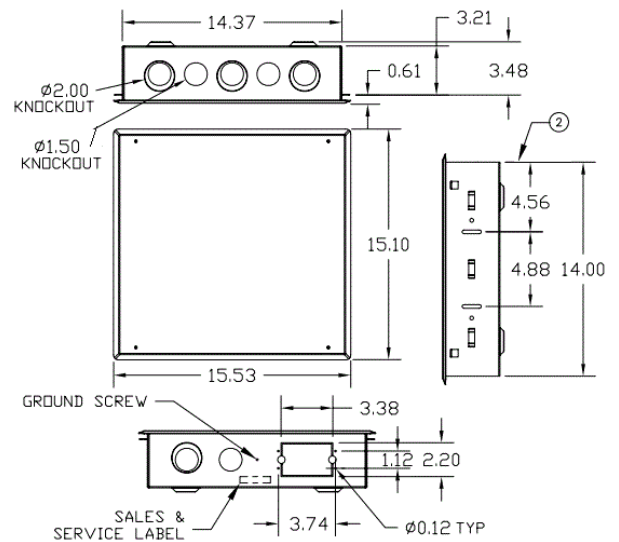

Dimensions in Inches (mm)

Hubbell Wiring Device-Kellems • Hubbell Incorporated (Delaware) • 40 Waterview Drive • Shelton, CT 06484

Phone (800) 288-6000 • Fax (800) 255-1031 • Specifications subject to change without notice.

