

netSELECT

Network Enclosures

14-Inch Network Enclosure

Features

- Horizontal And Vertical Module Mounting Holes For Maximum Flexibility
- Horizontal And Vertical Module Mounting Holes For Maximum Flexibility
- Recommended Module Unit Capacity: 5

Ordering Information

Description	Color	UPC Number	CatalogNumber
14-Inch Network Enclosure, Box Only	White	883778503139	NSOBOX14B

Listings

UL and cUL Listed
RoHS Compliant

Specifications

Material	High Impact Thermoplastic UL 94 V-0
Units	1

Complementary Products

Power Kit	NSOKPTR
Surge Protected Power Kit	NSOKPS
Panel Cover	NSOBOX14C
Hinged Door	NSOBOX14D

Online Resources

Customer Use Drawing
eCatalog

HUBBELL

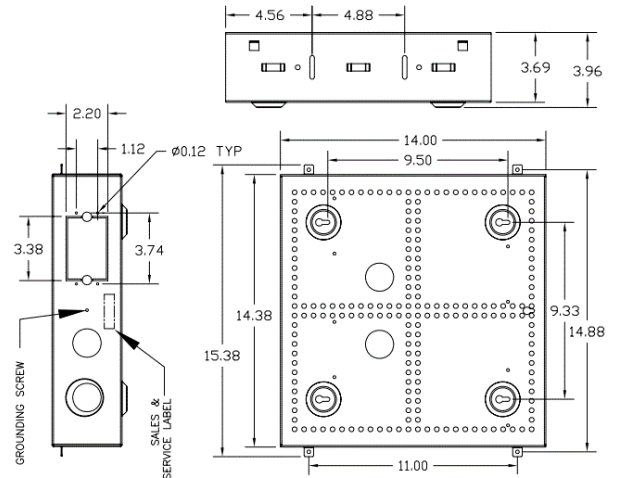

Dimensions in Inches (mm)

Hubbell Wiring Device-Kellems • Hubbell Incorporated (Delaware) • 40 Waterview Drive • Shelton, CT 06484

Phone (800) 288-6000 • Fax (800) 255-1031 • Specifications subject to change without notice.

