

Raceway
Non-Metallic Raceway
PL1 LANTrak® (Latching) External Elbow
Base and Cover

HUBBELL

Features

- Full capacity 1¼ in. bend radius external elbow.

Ordering Information

Description	Color	UPC Number	Catalog Number
External Elbow Base and Cover	Black	783585562650	PL1EECBK

Listings

UL Listed
CSA Certified

Specifications

Height	1.57"
Width	5.06"
Length	5.06"

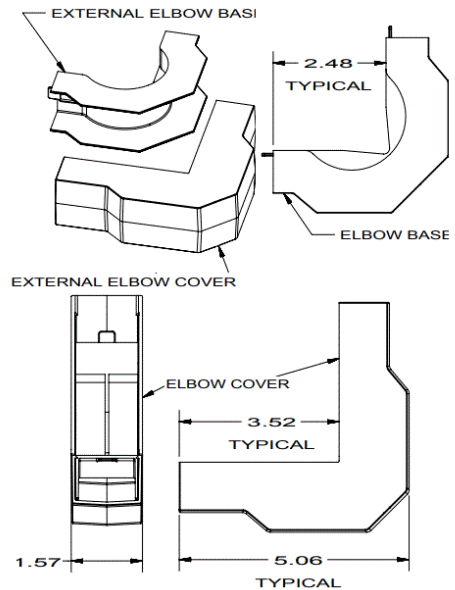
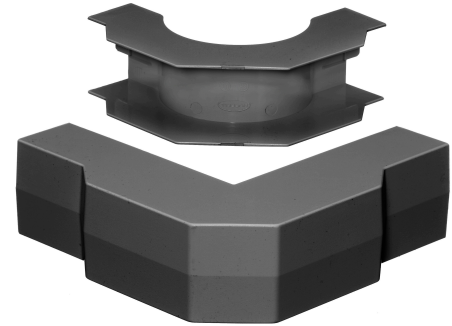

Online Resources

Customer Use Drawing
eCatalog
Installation Instructions

Dimensions in Inches (mm)

Hubbell Wiring Device-Kellems • Hubbell Incorporated (Delaware) • 40 Waterview Drive • Shelton, CT 06484

Phone (800) 288-6000 • Fax (800) 255-1031 • Specifications subject to change without notice.

