

Raceway  
Non-Metallic Raceway  
Non-Latching PremiseTrak® External Elbow  
Cover

# HUBBELL

### Features

- For outside surfaces at right angles.

### Ordering Information

Description	Color	UPC Number	Catalog Number
External Elbow Cover	Office White	783585337999	PT1EE

### Listings

UL Listed  
CSA Certified

### Specifications

Height	0.88"
Width	1.24"
Length	1.24"

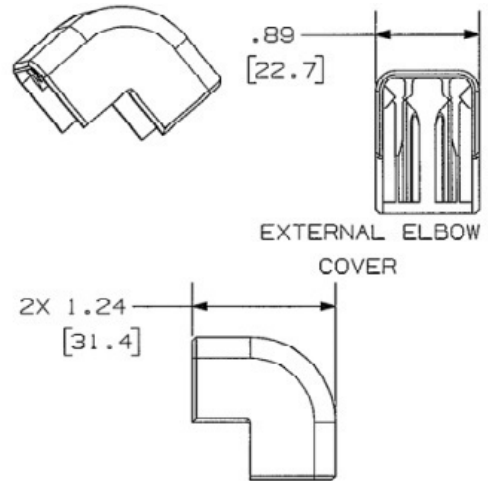

### Online Resources

Customer Use Drawing  
eCatalog  
Installation Instructions

Dimensions in Inches (mm)

Hubbell Wiring Device-Kellems • Hubbell Incorporated (Delaware) • 40 Waterview Drive • Shelton, CT 06484

Phone (800) 288-6000 • Fax (800) 255-1031 • Specifications subject to change without notice.

