

Raceway
Non-Metallic Raceway
PW2 WallTrak® (Latching) Internal Elbow
Base and Cover

HUBBELL

Features

- Full capacity 1¼ in. bend radius external elbow.

Ordering Information

| Description | Color | UPC Number | Catalog Number |
|-------------------------------|--------------|--------------|----------------|
| Internal Elbow Base and Cover | Office White | 783585090702 | PW2IEBC |

Listings

UL Listed
CSA Certified

Specifications

| | |
|--------|-------|
| Height | 2.32" |
| Width | 2.83" |
| Length | 2.83" |

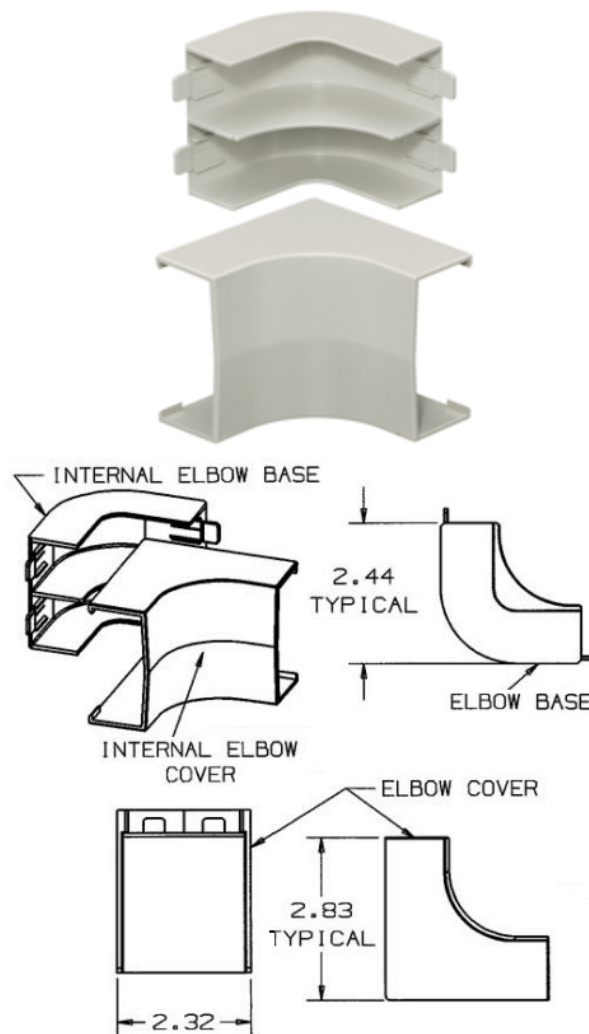

Online Resources

Customer Use Drawing
eCatalog
Installation Instructions

Dimensions in Inches (mm)

Hubbell Wiring Device-Kellems • Hubbell Incorporated (Delaware) • 40 Waterview Drive • Shelton, CT 06484

Phone (800) 288-6000 • Fax (800) 255-1031 • Specifications subject to change without notice.

