

Switches and Lighting Controls

500W Max, 120V AC

Vacancy Sensor Switch

HUBBELL

Ordering Information

Color	UPC	Catalog Number
Almond	883778112690	RMS101AL

Specifications

Sensing Range	42 to 54 Inches above the Floor
Indicator(s) Type	PIR= Red LED
Application	1-Button
Operating Cycles	6,000 Cycles Minimum
Mounting Hardware	Screw Mounting
California Title 24 Compliant	No Auto-On

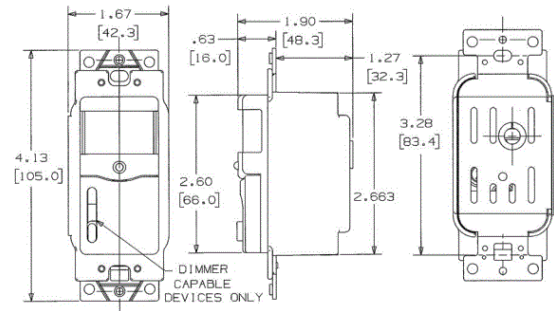

Online Resources

[Customer Sales Drawings](#)
[eCatalog](#)
[Installation Instructions](#)

Dimensions in Inches (mm)

Hubbell Wiring Device-Kellems • Hubbell Incorporated (Delaware) • 40 Waterview Drive • Shelton, CT 06484

Phone (800) 288-6000 • Fax (800) 255-1031 • Specifications subject to change without notice.

