

Switches, Single Pole
15A, 120-277V AC
SNAPConnect® Heavy Duty Style Line®
Decorator Switches

HUBBELL

Features

- Steel, zinc plated bridge is corrosion resistant
- Thread cleaning captive mounting screw
- Self-grounding staple assures continuity to wall box

Ordering Information

Description	Toggle Color	UPC	Catalog Number
SNAPConnect® Rocker	White	783585189536	SNAP2101WNA

Listings

UL Listed
CSA Certified

Specifications

Top Material	Thermoplastic, Blue
Base Material	Thermoplastic, Black
Rocker Material	Thermoplastic
Contacts	Silver Alloy
Terminals	Brass

Performance

Electrical

Dielectric Voltage	Withstands 1500V AC minimum for 1 minute
Max. Continuous Current	15A
Max. Working Voltage	277V AC
Overload	Minimum 4.8 times rated current for 100 cycles
Temperature Rise	30°C maximum at rated current

Mechanical

Terminal Accommodations Uses SNAPConnect Connector

Environmental

Flammability	UL 94V-2
Operating Temperature	Max. continuous: 75°C; Min. continuous: -40°C without impact

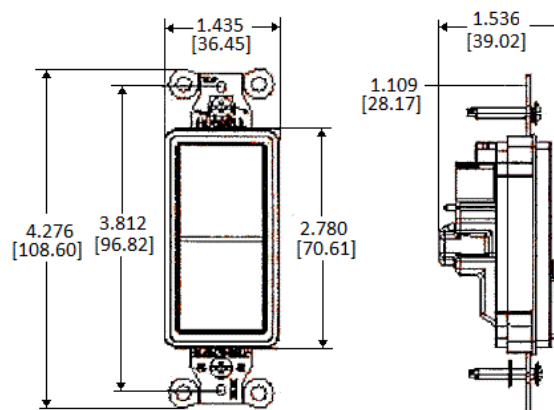

Online Resources

Customer Use Drawing
eCatalog
Installation Instructions

Dimensions in Inches (mm)

Hubbell Wiring Device-Kellems • Hubbell Incorporated (Delaware) • 40 Waterview Drive • Shelton, CT 06484

Phone (800) 288-6000 • Fax (800) 255-1031 • Specifications subject to change without notice.

