

## Straight Blade Devices

15 Amp, 125 Volt, 2-Pole, 3-Wire

# SNAPConnect<sup>®</sup> Extra Heavy Duty Receptacle

# HUBBELL

## Features

- Audible SNAP, indicates solid connection
- Reduces installation time
- Tamper-Resistant, Split Circuit
- Assembled in USA

## Ordering Information

Description	Device Color	UPC Number	Catalog Number
Tamper-Resistant, Split Circuit	Red	783585551623	SNAP2152RSCTRA



## Listings

UL Listed to UL498 File No. E2230  
Certified to CSA, C22.2, No. 42 File 329  
Fed. Spec. W-C-640  
NEMA<sup>®</sup> WD-6 Compliant

## Specifications

Face	Nylon
Base	Nylon
Line Contact	Brass
Ground Contact	Brass

## Performance

### Electrical

Current Interrupting	Certified for current interrupting at full rated current
Dielectric Voltage	Withstands 2,000V minimum

### Mechanical

Product Identification	Ratings are a permanent part of the device
------------------------	--

### Environmental

Flammability	UL 94V-2
Operating Temperature	Maximum continuous 75°C; minimum -40°C (without impact)

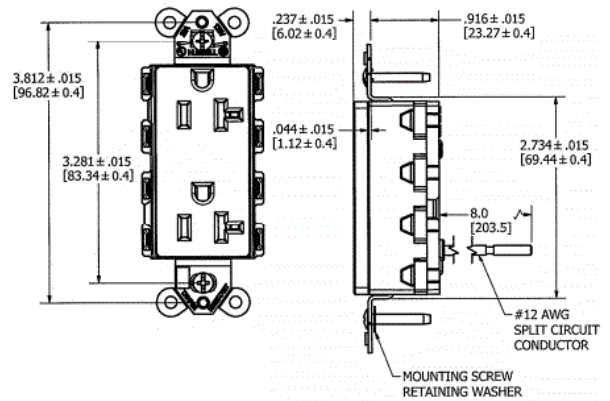

## Complementary Products

Wallplate or Weatherproof Cover  
Opening

## Online Resources

eCatalog

Dimensions in Inches (mm)

Hubbell Wiring Device-Kellems • Hubbell Incorporated (Delaware) • 40 Waterview Drive • Shelton, CT 06484

Phone (800) 288-6000 • Fax (800) 255-1031 • Specifications subject to change without notice.

