

Straight Blade Devices

20A, 125V, 2 Pole, 3 Wire Grounding

Hospital Grade SNAPConnect® Receptacle

HUBBELL

Features

- Requires minimal box space
- Self-grounding clip makes installation ease
- One-piece nickel-plated brass integral ground strap

Ordering Information

Description	Device Color	UPC Number	Catalog Number
Standard Duplex	White	883778305566	SNAP8300USBW

Listings

UL Listed to UL498 File No. E2561
Certified to CSA, C22.2, No. 42 File 682
Fed. Spec. W-C-993
NEMA® WD-6 Compliant

Specifications

Face	Nylon
Base	PBT
Power Contacts	Brass
Ground Contacts	Brass
Mounting Strap	Brass
Automatic Self-Grounding Clip	Stainless Steel
Mounting Screws	Zinc plated steel

Performance

Electrical	
Current Interrupting	Certified for current interrupting at full rated current
Dielectric Voltage	Withstands 2,000V minimum
Mechanical	
Product Identification	Ratings are a permanent part of the device
Environmental	
Flammability	UL 94V-8
Operating Temperature	Maximum continuous 75°C; minimum -40°C (without impact)

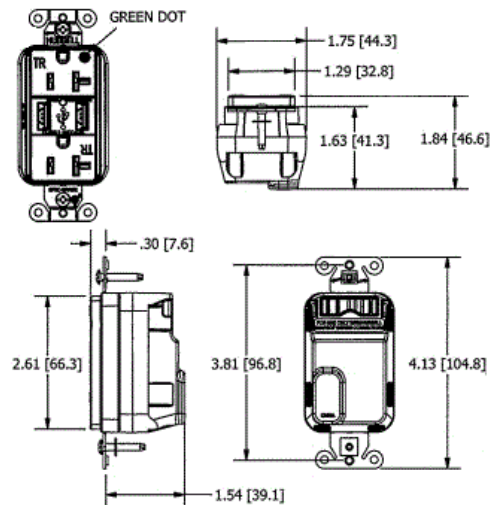

Complementary Products

Wallplate or Weatherproof Cover
Opening

Online Resources

Customer Sales Drawing
eCatalog
Installation Instructions

Dimensions in Inches (mm)

Hubbell Wiring Device-Kellems • Hubbell Incorporated (Delaware) • 40 Waterview Drive • Shelton, CT 06484

Phone (800) 288-6000 • Fax (800) 255-1031 • Specifications subject to change without notice.

