

Features

- Flip top link design
- Fiberglass reinforced nylon construction
- Highly wear resistant design provides corrosion resistance

Ordering Information

Color Black	UPC 783585343341	Catalog Number HCT102191
-----------------------	----------------------------	------------------------------------

Specifications

Application	Cable and Hose Carrier
Depth	0.75
Wire Size	.900"

Performance

Environmental	
Max. Operating Speed	600 FPM (feet per minute), 180 MPM (meters per minute)
Max. Unsupported Travel Distance	HCT16 Series without sag 9 ft. (2.8 m) with sag 10.5 ft. (3.2 m); HCT25 Series without sag 13.5 ft. (4.1 m) with sag 17 ft. (5.2 m)
Operating Temperature	Continuous +20°F to +100°F (-7°C to 38°C); Intermittent* -40°F to +220°F (-40°C to 104°C)

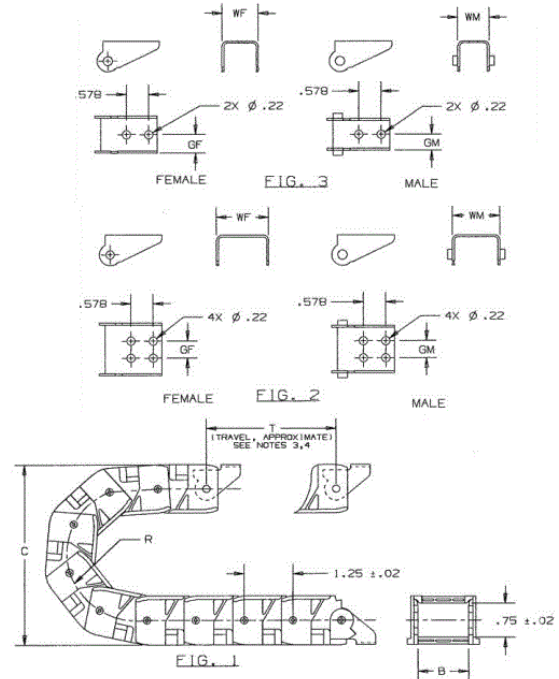

Online Resources

- Customer Sales Drawings
- eCatalog
- Installation Instructions