

Ordering Information

Color Black	UPC 783585022116	Catalog Number HCTSP25PK12
-----------------------	----------------------------	--------------------------------------

Specifications

Application	Cable and Hose Carrier
--------------------	------------------------

Performance

Environmental

Maximum Operating Speed	600 FPM (feet per minute), 180 MPM (meters per minute)
Operating Temperature	Continuous +20°F to +100°F (-7°C to 38°C); Intermittent* -40°F to +220°F (-40°C to 104°C).

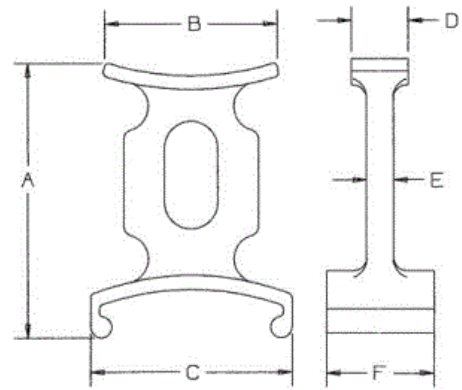
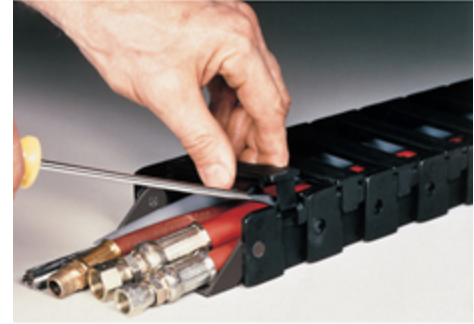

Online Resources

Customer Sales Drawings
eCatalog
Installation Instructions