

Type:
Job:
Ordering Example:

1A / AE17H3 / 150PMH277 / LG-P / HA37S / HAF2

Mtg Fixture Elec Module Finish Options

Ordering Information

Always refer to the specific luminaire catalog, and the ordering information page within that catalog. Place the optional Heritage Arm catalog number as an "Option" following the Fixture catalog numbers

Approvals:

Date:
Page: 1 of 2

Specifications

HA37L

Large Arm

for Kim RA25, AE21, BE21, and LET26 fixtures only.

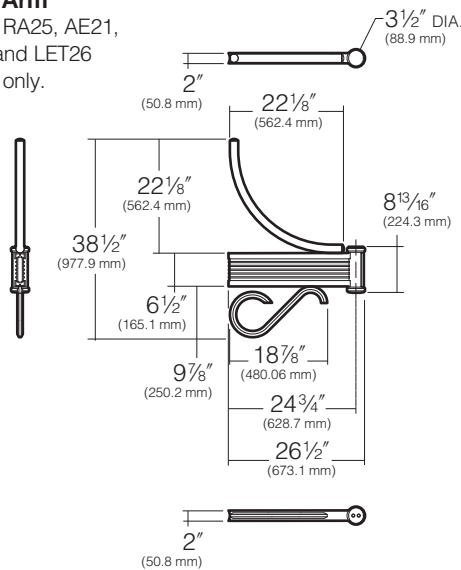

HA37S

Small Arm

for Kim RA17, AE17, BE17, and LET19 fixtures only.

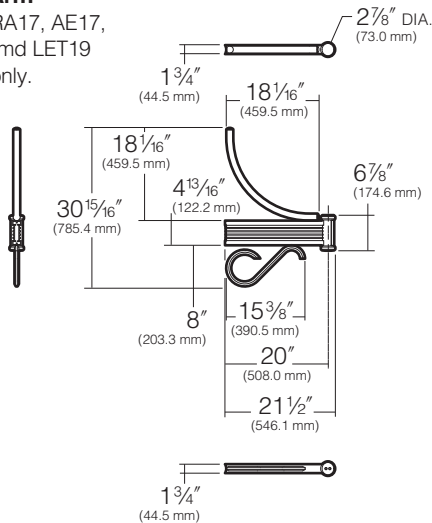

Arm: Extruded aluminum side-mounted arm with extruded aluminum curved brace mounted to top and cast aluminum scroll mounted to bottom. Brace is extruded aluminum tube attached to the fixture support arm on one end and to pole on the opposite end. Scroll attached to bottom of arm. Fixture mounting hub is open for access to wiring connections and stainless steel mounting rods, and enclosed by a flush mounted cast aluminum cover secured with stainless steel screws. Cast aluminum finial may be selected to close off top of mounting hub (flat cap standard). Attachment to pole is by 3/8" stainless steel rods, nuts and washers. Stainless steel rods thread into a pole backing plate located inside the pole. Pole backing plate is heavy gauge zinc plated steel, and includes a wire strain relief and grounding connection. For round poles, arm is circular cut for the specific pole diameter. Arm-to-luminaire attachment is by concealed stainless steel rods, projecting into the fixture where nuts and washers secure the mounting. Small arm utilizes 3/8" studs and large arm utilizes 1/2" studs.

Finish: Premium Super TGIC thermoset polyester power coating, 2.5 mil nominal thickness, applied over a titanated zirconium conversion coating. Arm color is always provided to match the selected pole and luminaire color.

Optional Arm Finial: (See page 2)





Optional Wall Mount not available.

NOTES:





- 1) Refer to page **75** of Arms and Poles Selection Guide for wind map and application information.
- 2) Refer to pages **78** and **79** of Arms and Poles Selection Guide for luminaire Optical Centerline Matrix.
- 3) A regularly scheduled maintenance program must be established to insure paint coating is intact, corrosion or structural damage has not occurred, and all mounting rods, nuts and bolts are tight. Failure to do so could lead to damage or serious personal injury.

Type:
Job:

Standard Features

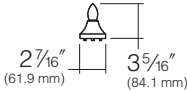
ERA® Arm	Arm/Fixture	Mounting Configuration				
HA37		Plan View:				
		Cat. No.:	1A	2B	3Y	4C
	Large HA37L - RA25 HA37L - AE21/BE21 HA37L - LET26 Small HA37S - RA17 HA37S - AE17/BE17 HA37S - LET19	EPA:				
			2.8	5.6	6.9	7.4
			2.7	5.4	6.6	7.0
			2.8	5.6	6.8	7.3
			1.8	3.6	4.5	4.8
	1.7	3.4	4.2	4.5		
	2.0	4.0	5.0	5.5		

Optional Features

<p>Arm Finials</p>	<p>Traditional style finial available to close off mounting hub opposite the fixture. Finial is cast aluminum finished to match arm and fixture powder coat color.</p>	 <p>2 7/16" (61.9 mm)</p>	 <p>3 5/16" (84.1 mm)</p>	 <p>1 7/8" (47.6 mm)</p>	 <p>2 9/16" (65.1 mm)</p>
		Cat. No: HAF2		Cat. No: HAF2	