

H8643

Shallow Depth, Wide Beam Downlight
One 26-32-42W Triple Tube Compact Fluorescent
6" Square Parabolic Trim

Optics and Applications

The socket is mounted horizontally in an ellipsoidal primary reflector for wide distribution and reduced recess depth in shallow plenums. Use in low to medium height ceilings for corridors, entries and for general and area lighting.

Design Features

A steel housing protects and aligns reflectors and lamps. The socket and ballast will accept all triple tube wattages interchangeably. The square trim is stabilized by a proprietary steel web to prevent racking and is held to the ceiling by constant pressure springs. Maximum ceiling thickness 1 1/2". Ballast and lamp service from below.

Finish

Housings and structural parts are painted matte black to suppress stray light leaks. Standard trim is anodized Softglow® clear. Special colors available, see accessories.

Ballast

Programmed rapid start, microprocessor controlled for rated lamp life and end of lamp life protection. Input voltage range is from 120V through 277V. Operates 26W, 32W or 42W triple tube lamps. Power factor .98. Starting temperature 0° F (-18°C), THD <10%.

General

Fixtures are pre-wired, UL and C-UL listed for damp location and eight wire 75°C branch circuit wiring. All products are union made. Designed and manufactured in the USA.

Warranty

5 Year Warranty. See www.kurtversen.com for details or select hyperlink.

Accessories

- SB Softglow black.
- SG Softglow gold.
- SW Softglow wheat.
- SY Softglow pewter.
- R2 26" support rails.
- R5 52" support rails.
- FR Frosting on lens, specify lens type.
- FLT6 Full lens trim, specify lens type, e.g. H8643-FLT6LL.
- DM Dimming ballast. Specify watts and volts.
- DM1 1% Lutron. Specify watts and volts.
- EM Emergency power includes integral charger light and test switch visible through aperture. Battery operation for 90 minutes.
- WRL Wattage restriction label, specify wattage.
- WT White trim flange.
- WHT White complete trim.
- LL Linear spread lens.
- SO Solite lens.

Dimensions and Lamps

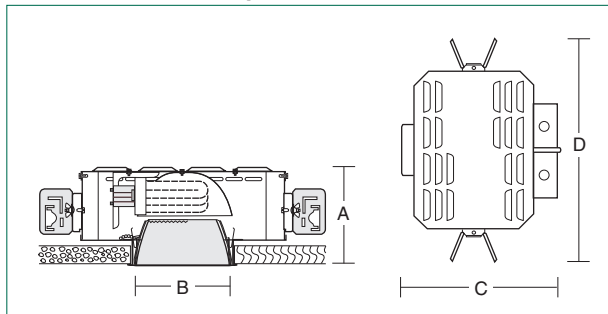

Number	A Depth	B Aperture	C Width	D Length	Lamps
H8643	6 1/2" 165mm	6" sq. 153mm	13 1/2" 343mm	19" 483mm	26-32-42W TripleTube compact fluorescent

Brightness

Number	Lamps	85°	75°	65°	55°	45°
H8643	32W T/E Osram/Syl	31	97	203	1221	10019
	32W PL-T Philips	37	108	218	6698	13729
	42W PL-T Philips	40	151	273	6857	19941
	42W T/E Osram/Syl	53	185	367	4566	17420

Data in footlamberts. Photometer readings, Maximum Brightness Method.

H8643

Cut out dimensions: 6^{21/32"}. Outer flange dimension: 7^{1/8"}.

Performance Datachart

Single Unit Initial Footcandles, 30" Work Plane						Ceiling to Floor		Multiple Units Initial Footcandles, 30" Work Plane							
H8643 One 32W Philips Triple Tube Read Top Data								Ceiling 80% Walls 50% Floor 20%							
H8643 One 42W Philips Triple Tube Read Bottom Data								Spacing is Maximum Over Work Plane							
Nadir		10		20		30		Spacing		RCR 1		RCR 3		RCR 8	
FC	FC	Diam	FC	Diam	FC	Diam									
19	18	2'	16	4'	10	6'	8'	7'	23	19	15				
29	27	2'	21	4'	13	6'		6'	38	32	21				
21	13	2'	11	5'	7	8'	9'	8'	16	14	11				
18	19	2'	15	5'	10	8'		7'	27	23	15				
10	10	3'	8	5'	5	9'	10'	9'	12	10	8				
16	14	3'	11	5'	7	9'		8'	20	17	11				
8	8	3'	7	6'	4	10'	11'	10'	10	8	6				
12	11	3'	9	6'	6	10'		9'	16	14	9				
6	6	3'	5	7'	3	11'	12'	12'	8	6	5				
10	9	3'	7	7'	4	11'		10'	13	11	7				

Candlepower Distribution

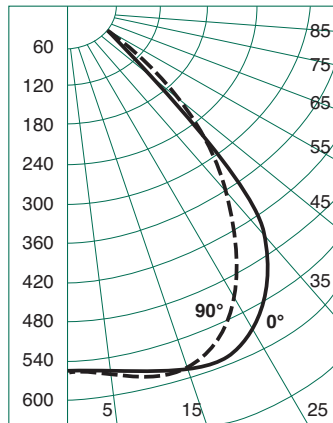

H8643 One 32W Triple Tube Philips
Eff. 39% S/M 0 1.30 S/M 90 1.14

Candelas

	0		90	
	2400*	2400*	2400*	2400*
0	560	560	560	560
5	561	565	565	565
10	568	579	579	579
15	585	581	581	581
20	588	567	567	567
25	558	516	516	516
30	521	431	431	431
35	455	359	359	359
40	358	283	283	283
45	256	194	194	194
50	165	124	124	124
55	92	59	59	59
60	22	21	21	21
65	9	12	12	12
70	0	0	0	0
75	0	0	0	0
80	0	0	0	0
85	0	0	0	0
90	0	0	0	0

Vertical Angles
* Initial Lamp Lumens

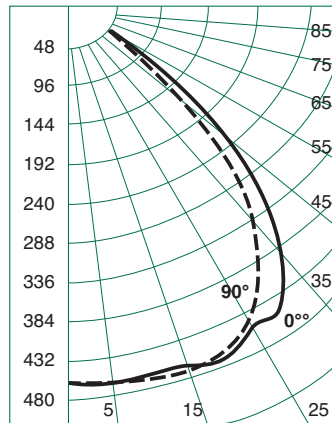

H8643 One 32W Triple Tube Osram Sylvania
Eff. 33% S/M 0 1.36 S/M 90 1.24

	0		90	
	2400*	2400*	2400*	2400*
0	457	457	457	457
5	466	460	460	460
10	464	470	470	470
15	469	476	476	476
20	475	473	473	473
25	448	452	452	452
30	457	399	399	399
35	396	337	337	337
40	316	255	255	255
45	233	170	170	170
50	136	99	99	99
55	52	34	34	34
60	13	14	14	14
65	8	9	9	9
70	6	7	7	7
75	0	0	0	0
80	0	0	0	0
85	0	0	0	0
90	0	0	0	0

Vertical Angles
* Initial Lamp Lumens

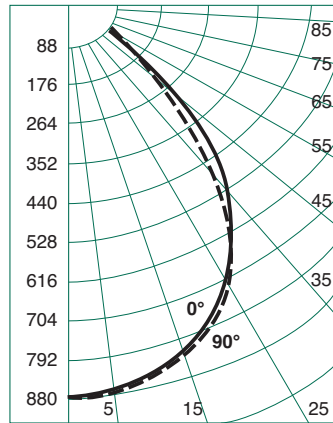

H8643 One 42W Triple Tube Philips
Eff. 38% S/M 0 1.07 S/M 90 1.06

	0		90	
	3200*	3200*	3200*	3200*
0	880	880	880	880
5	866	869	869	869
10	842	843	843	843
15	813	816	816	816
20	768	781	781	781
25	694	710	710	710
30	619	602	602	602
35	508	461	461	461
40	386	322	322	322
45	266	235	235	235
50	172	173	173	173
55	107	113	113	113
60	50	50	50	50
65	19	17	17	17
70	0	0	0	0
75	0	0	0	0
80	0	0	0	0
85	0	0	0	0
90	0	0	0	0

Vertical Angles
* Initial Lamp Lumens

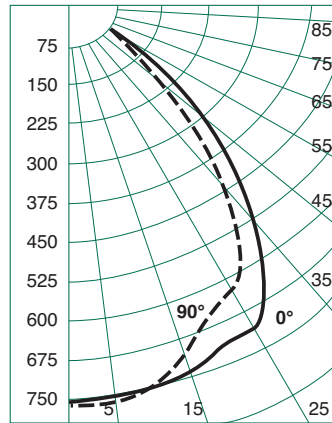

H8643 One 42W Triple Tube Osram Sylvania
Eff. 35% S/M 0 1.21 S/M 90 1.13

	0		90	
	3200*	3200*	3200*	3200*
0	757	757	757	757
5	750	761	761	761
10	751	741	741	741
15	746	704	704	704
20	725	647	647	647
25	718	625	625	625
30	632	569	569	569
35	529	454	454	454
40	408	315	315	315
45	288	194	194	194
50	185	128	128	128
55	102	81	81	81
60	40	36	36	36
65	15	15	15	15
70	0	0	0	0
75	0	0	0	0
80	0	0	0	0
85	0	0	0	0
90	0	0	0	0

Vertical Angles
* Initial Lamp Lumens

Notes

- Softglow® cone multipliers: Gold x .89, Wheat x .87, Pewter x .73.
- Single unit Datachart pattern diameters are determined by the number of degrees from each side of nadir. Therefore a 20 diameter represents a total 40 pattern width at the work plane 30" above the floor. Footcandle values are at the edge of that diameter.
- Datachart spacing is rounded off to the nearest foot.
- Data by IES methods. Compact fluorescent data vary due to lamp lumen differences, power input, burning position, ambient temperature and ballast characteristics. A modification factor should be applied.

Brightness

Number	Lamps	85°	75°	65°	55°	45°
H8643	32W T/E Osram/Syl	31	97	203	1221	10019
	32W PL-T Philips	37	108	218	6698	13729
	42W PL-T Philips	40	151	273	6857	19941
	42W T/E Osram/Syl	53	185	367	4566	17420

Data in footlamberts. Photometer readings. Maximum Brightness Method.

Coefficients of Utilization

Ceiling	80%					70%		50%		30%		0
	70	50	30	10	50	10	50	10	50	10	0	
Wall %	70	50	30	10	50	10	50	10	50	10	0	
RCR	Zonal Cavity Method - Floor Reflectance 20%											
1	.43	.41	.40	.39	.41	.39	.39	.38	.38	.36	.35	
2	.40	.38	.36	.35	.37	.34	.36	.34	.35	.33	.31	
3	.38	.35	.33	.31	.34	.31	.33	.30	.32	.30	.29	
4	.35	.32	.30	.28	.32	.28	.31	.27	.30	.27	.26	
5	.33	.29	.27	.25	.29	.25	.28	.25	.28	.24	.24	
6	.31	.27	.25	.23	.27	.23	.26	.22	.26	.22	.22	
7	.29	.25	.23	.21	.25	.21	.24	.21	.24	.20	.20	
8	.28	.23	.21	.19	.23	.19	.23	.19	.22	.19	.18	
9	.26	.22	.19	.18	.22	.18	.21	.17	.21	.17	.17	
10	.25	.20	.18	.16	.20	.16	.20	.16	.20	.16	.16	

H8643 One 42W Philips
H8643 One 32W Philips x 1.00

H8643 One 42W Osram x .93
H8643 One 42W Osram x .86