

Type: _____
 Project Name: _____
 Notes: _____

Sample AA-39 S 4 B P BBT
 Ordering _____ / _____ / _____ / _____ / _____ / _____
A B C D E F

DETAILS

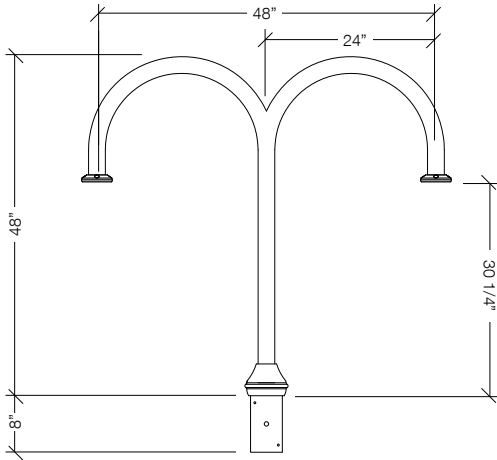

WALL BRACKET DETAILS

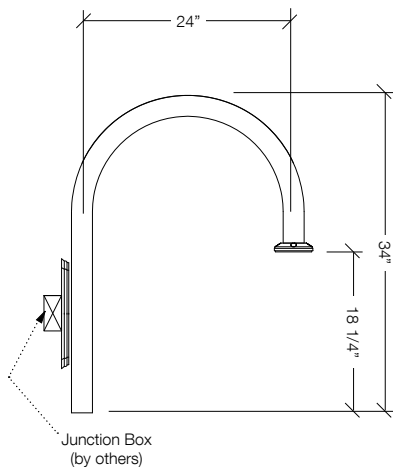

WALL PLATE DETAILS

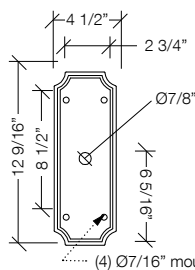

Due to our continued efforts to improve our products, product specifications are subject to change without notice.

A. MODEL

AA-39 Railroad

B. POST SHAFT PROFILE

W wall mount
S smooth
F fluted

C. POST SHAFT DIAMETER

4 4"
5 5"
6 6"

OTHER _____

D. ARRANGEMENT

_____ see arrangement table below

E. LUMINAIRE MOUNTING

P pendant

F. COLOR

BBT basic black textured
BMT black matte textured
WHT white textured
MBT metallic bronze textured
BZT bronze textured
DBT dark bronze textured
GYS gray smooth
DPS dark platinum smooth
GNT green textured
MST metallic silver textured
MTT metallic titanium textured
OWI old world iron
RAL _____

Construction: All cast aluminum parts shall be low copper alloy A356. All extruded aluminum parts shall be alloy 6061-T6, 6063-T5 or equal.

EPA (effective projected area): EPA is defined as (projected surface area X drag factor) and measured in ft². Allowable post, luminaire arm, luminaire and accessory EPAs are derived from the most current published AASHTO (American Association of State Highway and Transportation Officials) standard, currently AASHTO 2001 (50yr design life). Customer assumes all responsibility for selecting the appropriate post for installation (consult factory for assistance). Luminaire arm, luminaire and accessory EPA must be equal to or less than allowable EPA of post. Consult a professional engineer for compliance with local codes and standards.

Fasteners: All fasteners shall be Corrosion Resistant. When tamper resistant fasteners are required, spanner HD (snake eye) style shall be provided (special tool required, available at additional cost).

Finish: Finish shall be a Beacote V polyester powder-coat electro-statically applied and thermocured. Beacote V finish shall consist of a five stage iron phosphate chemical pretreatment regimen with a polymer primer sealer, oven dry off, and top coated with a thermoset super TGIC polyester powder coat finish. The finish shall meet the AAMA 605.2 performance specification which includes passing a 3000 hour salt spray test for corrosion resistance and resists cracking or loss of adhesion per ASTM D522 and resists surface impacts of up to 160 inch-pound.

Limited Warranty: Beacon Products warrants its products, to the original purchaser, against defects in materials and workmanship for proper usage for a period of 5 years after date of production, when properly installed, maintained and appropriately specified. See Warranty Information on www.beaconproducts.com for complete details and exclusions.

		arrangement (EPA index ft ² / weight (lbs))									
		A	B	C	D	E	F	G	H	I	J
shaft Ø											
wall	weight	10	-	-	-	-	-	-	-	-	-
Ø4"	EPA	-	1.83	2.70	-	2.79	3.30	-	3.35	4.38	-
	weight	-	14	19	-	25	31	-	31	36	-
Ø5"	EPA	-	1.92	2.79	-	2.88	3.39	-	3.44	4.47	-
	weight	-	15	20	-	26	32	-	32	37	-
Ø6"	EPA	-	2.01	2.88	-	2.97	3.48	-	3.53	4.56	-
	weight	-	16	21	-	27	33	-	33	38	-