

Revisions

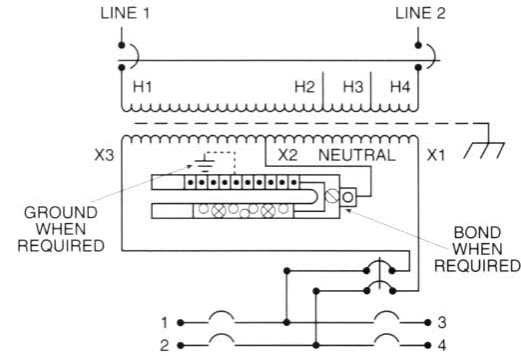
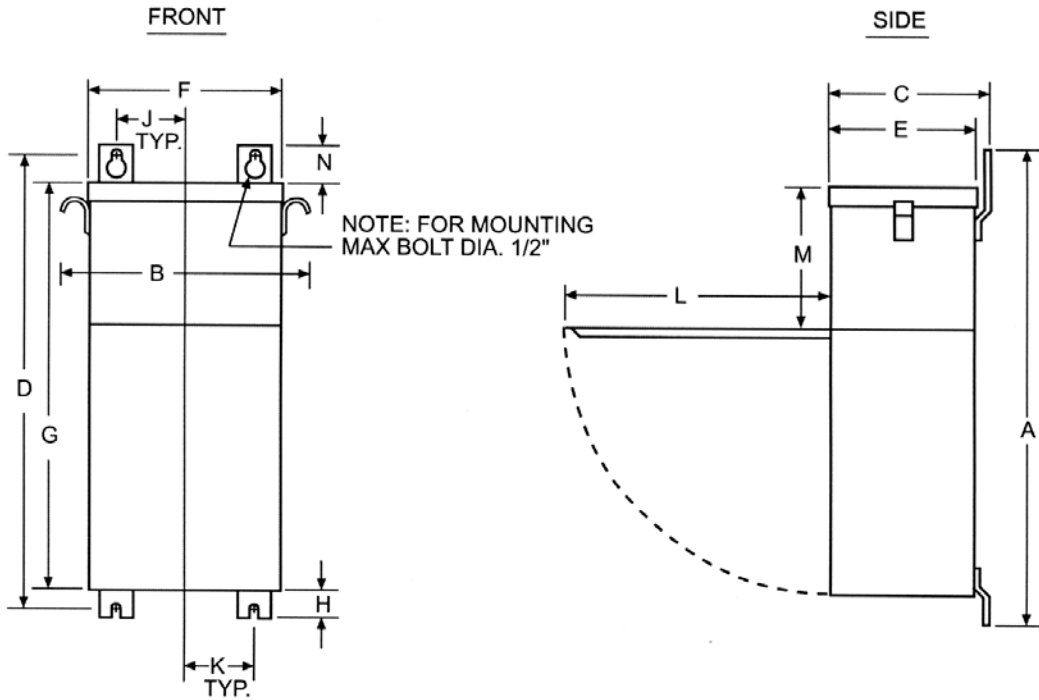

PANEL-TRAN

Type No.

| KVA | CATALOG NUMBER | VOLTAGE | | Stainless Steel | WEIGHT | PHASE | FREQ. |
|-----|------------------------|---------|---------|-----------------|---------|----------|-------|
| | | HIGH | LOW | | | | |
| 5.0 | PT06-1150005-SS | 480 | 120/240 | 304 | 120 Lbs | 1 ϕ | 60 Hz |

TYPICAL PERFORMANCE DATA

| | |
|--------------|-------|
| Winding Rise | 115°C |
| Insulation | 180°C |
| Sound Level | 40 dB |

| | |
|----------------|---|
| 120 V (1-Pole) | 8 |
|----------------|---|

| | |
|----------------|---|
| 240 V (2-Pole) | 4 |
|----------------|---|

| | |
|--------------------|--|
| Typical Efficiency | |
| Full Load Losses | |
| No Load Losses | |

| A | B | C | D | E | F | G | H | J | K | L | M | N | | |
|-------|-------|------|-------|------|-------|-------|------|------|------|-------|-------|------|--|--|
| 32.13 | 13.25 | 7.63 | 30.63 | 7.06 | 10.31 | 27.81 | 1.50 | 3.00 | 3.00 | 17.25 | 10.06 | 2.63 | | |

| | | | | | | | | | |
|--|--|--|--|--|--|----------|-----------|------------------|------------------------|
| | | | | | | A | PRINTS TO | CONTROL 7 | PT06-1150005-SS |
|--|--|--|--|--|--|----------|-----------|------------------|------------------------|