

# Revisions

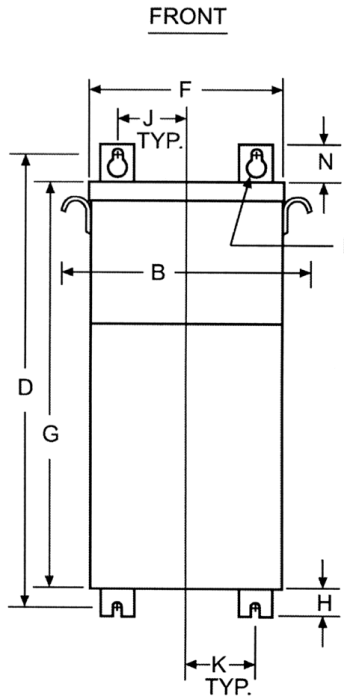

NOTE: FOR MOUNTING  
MAX BOLT DIA. 1/2"

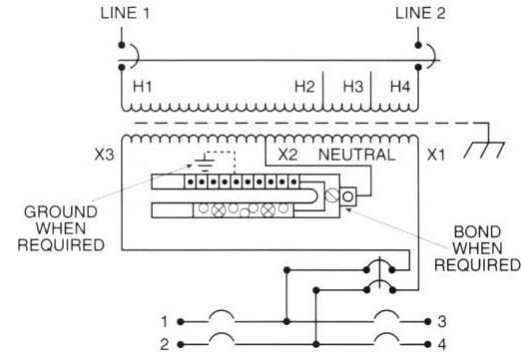
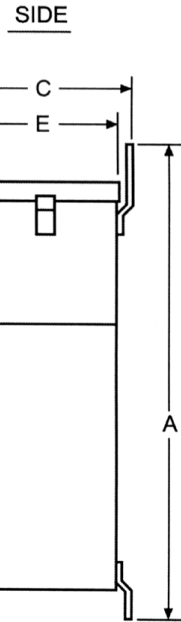

## PANEL-TRAN

Type No.

KVA	CATALOG NUMBER	VOLTAGE		Enclosure	WEIGHT	PHASE	FREQ.
		HIGH	LOW				
15	<b>PT06-1150015-LS</b>	480	120/240	NEMA-3R	240 Lbs	1 $\phi$	60 Hz

### TYPICAL PERFORMANCE DATA

Winding Rise	115°C
Insulation	180°C
Sound Level	45 dB

120 V (1-Pole)	12
-------------------	----

240 V (2-Pole)	6
-------------------	---

Typical Efficiency	
Full Load Losses	
No Load Losses	

A	B	C	D	E	F	G	H	J	K	L	M	N		
34.38	17.13	12.38	32.88	10.68	14.18	30.06	1.50	4.00	4.00	15.75	13.69	2.63		

					<b>A</b>	PRINTS TO	<b>CONTROL 7</b>	<b>PT06-1150015-LS</b>
--	--	--	--	--	----------	--------------	----------------------	------------------------