

# Revisions

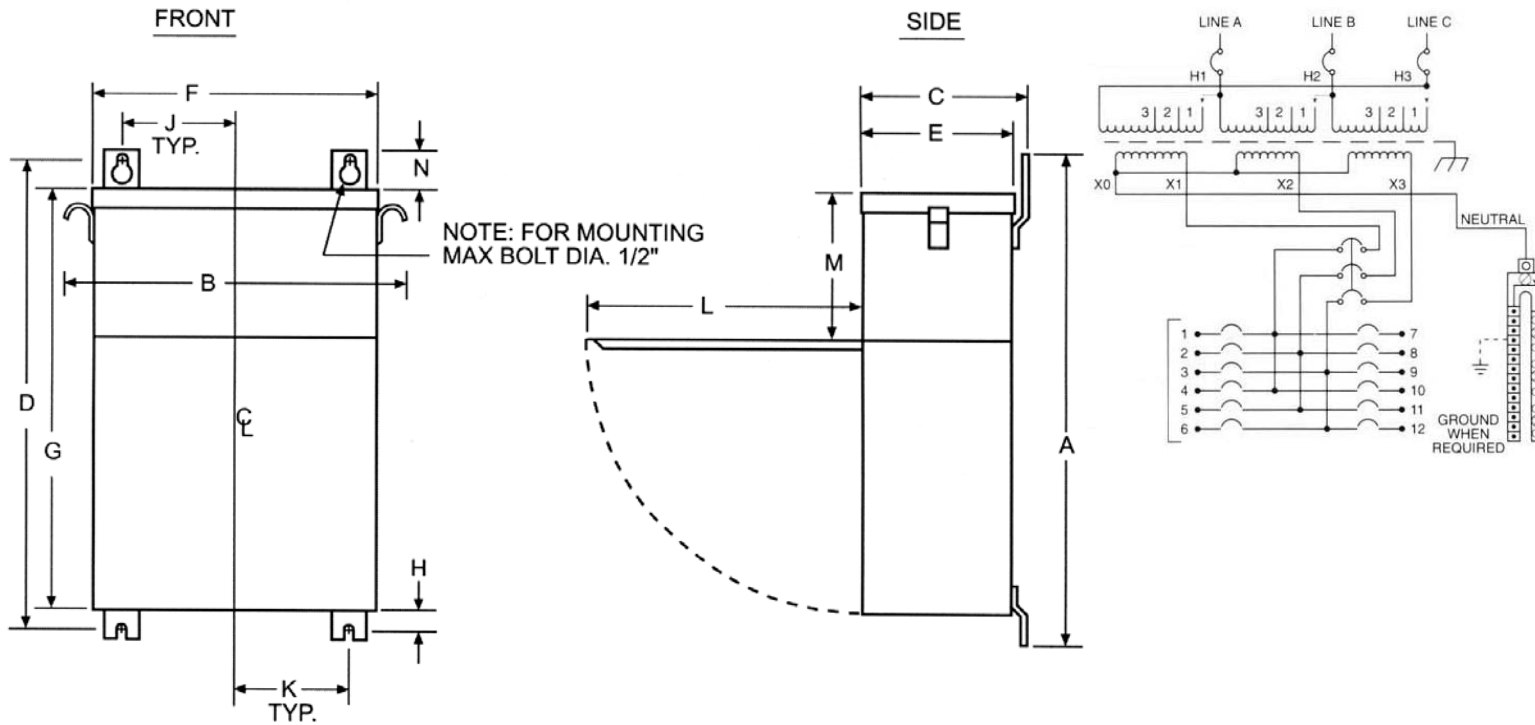

## PANEL-TRAN

Type No.

KVA	CATALOG NUMBER	VOLTAGE		Stainless Steel	WEIGHT	PHASE	FREQ.
		HIGH	LOW				
15	<b>PTBA-3150015-SS</b>	480Δ	208Y/120	304	385 Lbs	3φ	60 Hz

### TYPICAL PERFORMANCE DATA

Winding Rise	115°C	120 V (1-Pole)		12	208 V (3-Pole)		4	Typical Efficiency	
Insulation	180°C							Full Load Losses	
Sound Level	45 dB							No Load Losses	

A	B	C	D	E	F	G	H	J	K	L	M	N		
34.13	22.13	12.38	33.75	11.81	19.19	31.06	1.44	8.00	8.00	16.88	13.56	2.63		

					<b>A</b>	PRINTS TO	<b>CONTROL 7</b>	<b>PTBA-3150015-SS</b>
--	--	--	--	--	----------	-----------	------------------	------------------------