

Revisions

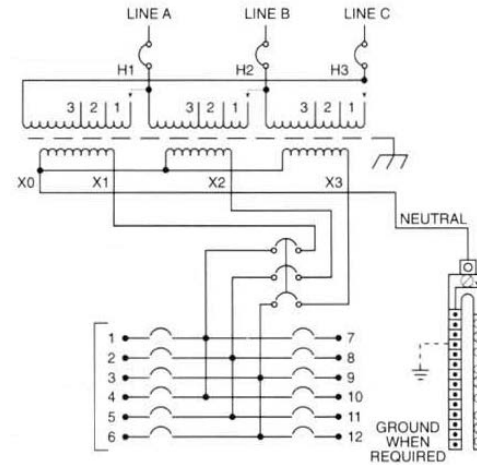

Reference Drawing Only
See Circuit Breaker Data Below.

Primary Volts	%	Connect Leads To Tap Number
480	100	1
456	95	2
432	90	3

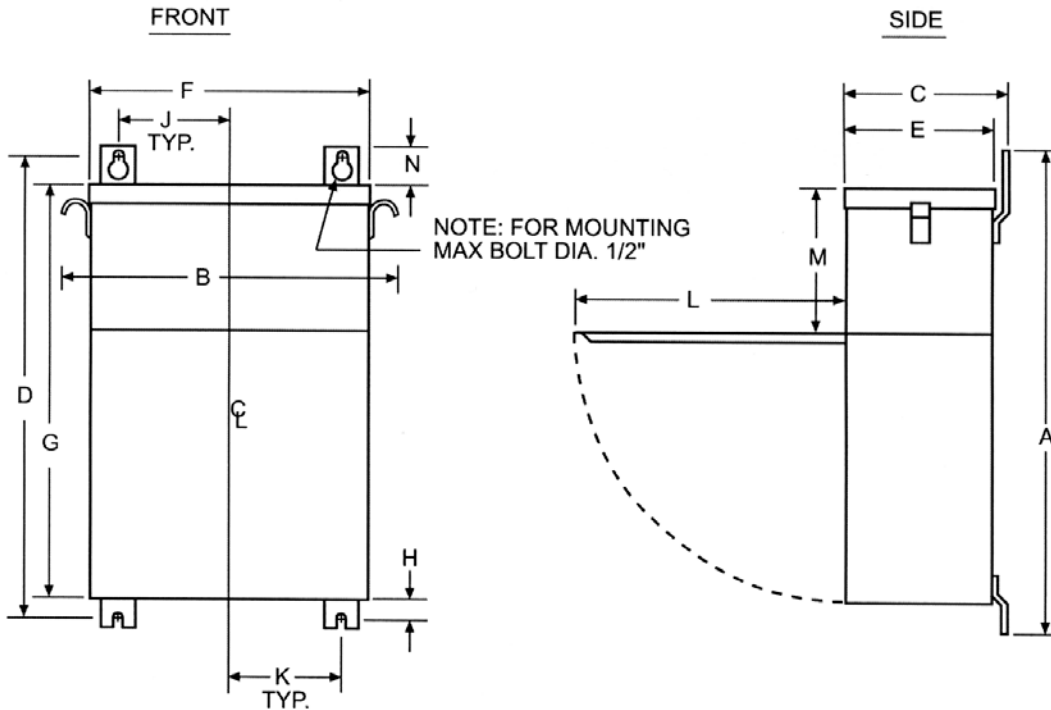

PANEL-TRAN

Type No.

KVA	CATALOG NUMBER	VOLTAGE		Stainless Steel	WEIGHT	PHASE	FREQ.
		HIGH	LOW				
30	PTBA-3150030-SS	480Δ	208Y/120	304	680 Lbs	3φ	60 Hz

TYPICAL PERFORMANCE / CIRCUIT BREAKER DATA

Winding Rise	115°C
Insulation	180°C
Sound Level	45 dB

120 V (1-Pole)	24
-----------------------	-----------

208 V (3-Pole)	8
-----------------------	----------

NEMA	3R
Primary Breaker:	90A-3P
Secondary Main Breaker:	100A-3P

A	B	C	D	E	F	G	H	J	K	L	M	N
43.75	33.00	13.75	42.25	13.19	30.06	39.56	1.44	8.00	8.00	22.88	16.06	2.63

Primary -----18,000 AIC

Secondary – 10,000 AIC

A

PRINTS TO

CONTROL 7

PTBA-3150030-SS