

Revisions

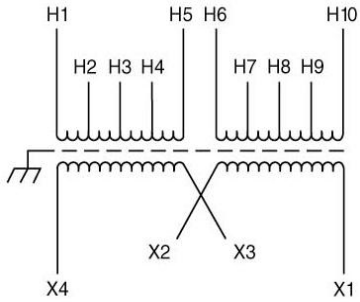

Primary Volts	Connect Primary Lines To	Inter-Connect	Connect Secondary Lines To
190	H1 & H7	H1 to H6 H2 to H7	
200	H1 & H8	H1 to H6 H3 to H8	
208	H1 & H9	H1 to H6 H4 to H9	
220	H1 & H10	H1 to H6 H5 to H10	
380	H1 & H7	H2 & H6	
400	H1 & H8	H3 & H6	
416	H1 & H9	H4 & H6	
440	H1 & H10	H5 & H6	
Secondary Volts			
240		X2 to X3	X1-X4
120/240		X2 to X3	X1-X2-X4
120		X1 to X3 X2 to X4	X1-X4

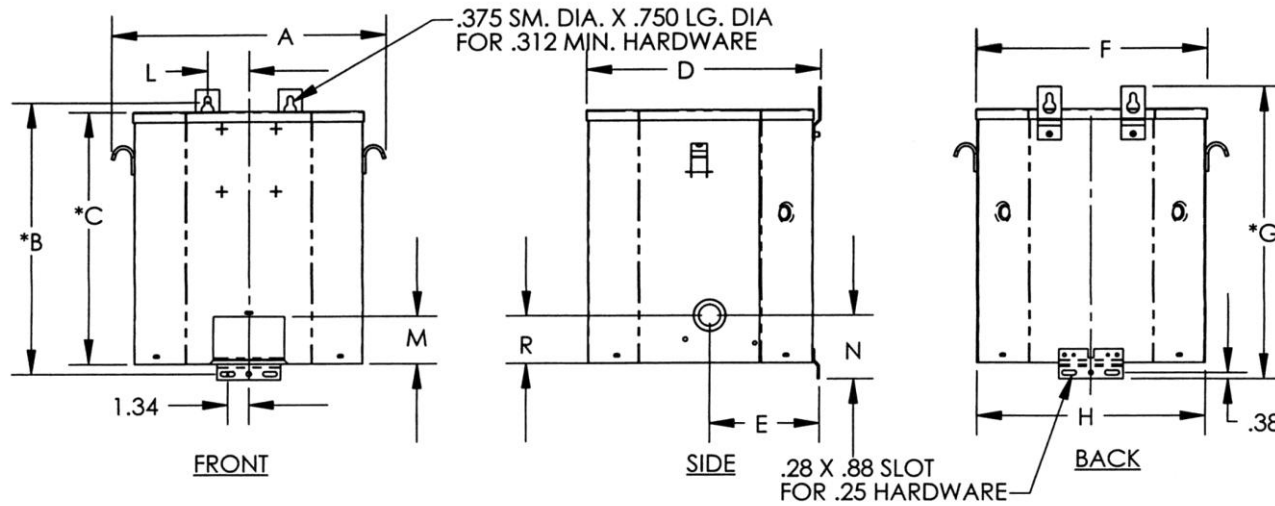
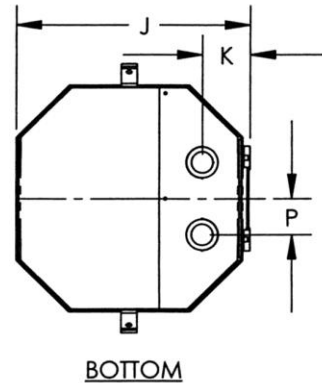

Type No.

KVA	CATALOG NUMBER	VOLTAGE		Enclosure	WEIGHT	PHASE	FREQ.
		HIGH	LOW				
10	TF-2-52795-S	190/200/208/220 380/400/416/440	120/240	NEMA-3R	125 Lbs	1	50/60 Hz

TYPICAL PERFORMANCE DATA

Winding Rise	115°C
Insulation	180°C
Sound Level	45 dB

Regulation @ 100% PF	
----------------------	--

IMPEDANCE	
-----------	--

Typical Efficiency	
Total Load Losses	242.5W
No Load Losses	

DATE: Oct 1, 2008

A	B	C	D	E	F	G	H	J	K	L	M	N	P	R
13.50	14.18	12.81	10.84	4.85	11.12	15.19	11.00	10.63	2.18	1.75	2.25	3.13	1.88	3.00

A

PRINTS TO

CONTROL
7