

Revisions

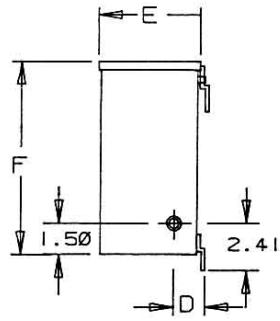

SIDE

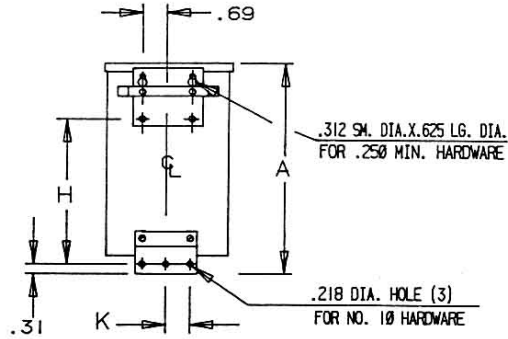

BACK (1)

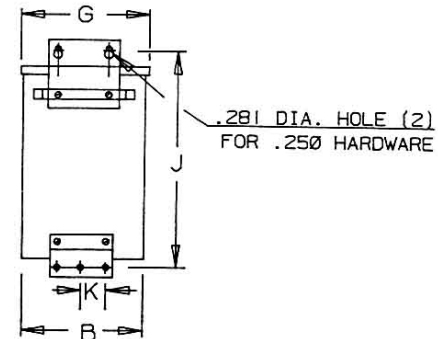

BACK (2)

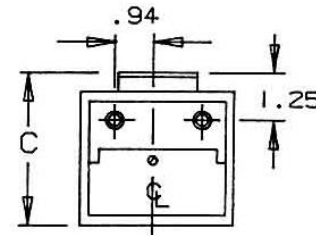

BOTTOM

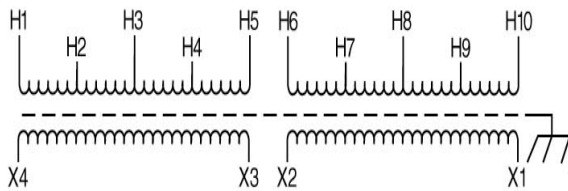

Primary Volts	Connect Primary Lines To	Inter-Connect	Connect Secondary Lines To
190	H1 & H7	H1 to H6 H2 to H7	
208	H1 & H8	H1 to H6 H3 to H8	
220	H1 & H9	H1 to H6 H4 to H9	
240	H1 & H10	H1 to H6 H5 to H10	
380	H1 & H7	H2 to H6	
416	H1 & H8	H3 to H6	
440	H1 & H9	H4 to H6	
480	H1 & H10	H5 to H6	
Secondary Volts			
240		X2 to X3	X1 - X4
120/240		X2 to X3	X1 - X2 - X4
120		X1 to X3 X2 to X4	X1 - X4

KVA	CATALOG NUMBER	VOLTAGE		WIRING DIAGRAM	WEIGHT	PHASE	FREQ.
		HIGH	LOW				
2.0	TF-2-79261-S	190/208/220/240 380/416/440/480	120/240		38 Lbs	1φ	50/60 Hz

TYPICAL PERFORMANCE DATA

Winding Rise	115°C	Regulation @ 100% PF	IMPEDANCE	Typical Efficiency	
Insulation	180°C			Full Load Losses	
Sound Level	45 dB			No Load Losses	

A	B	C	D	E	F	G	H	J	K
12.52	5.40	5.13	1.67	4.92	11.68	5.50	9.03	13.00	1.50



Type No.

A

PRINTS TO

CONTROL
7