



Application Guide

M-2264B Application Guide

**BECKWITH
ELECTRIC**  **CO. INC.**

Adapter Panel M-2264B

Adapts M-2001 Series Digital Tapchanger Control to Replace Balance Beam Controls for General Electric ML-32 Regulators

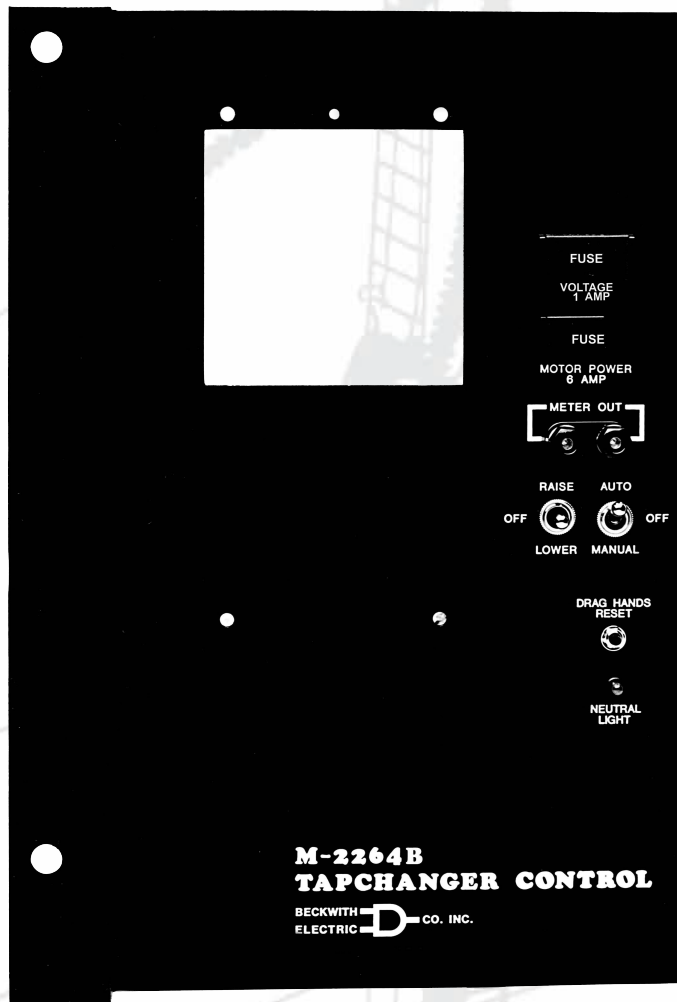

- Connects easily to the M-2001 Series Digital Tapchanger Control using mounting screws and 24-pin connector
- Provides direct mechanical replacement of the existing regulator control using the same two thumbscrews
- Provides built-in CT shorting protection when the M-2001 Series Digital Tapchanger Control is removed

The M-2264B is an adapter panel which, when combined with the M-2001 Series Digital Tapchanger Control, provides convenient direct replacement of balance beam controls for General Electric ML-32 regulators. The M-2264B mounts into the control cabinet using the same two thumbscrews which *must be saved* from the original control.

Interface

External connections are made via a wiring harness that connects from a fifteen-position terminal block to the terminal block on the existing control cabinet. An additional terminal block provides access to auxiliary functions, including self-test alarm, user-programmable alarm, auto disable and manual raise/lower.

Features

Separate fuses for voltage sensing and motor power are on the front panel. Spare fuses for each are in the fuse holder.

Binding post on the front panel allows easy connections for test procedures.

RAISE/OFF/LOWER and **AUTO/OFF/MANUAL** switches, **DRAG HANDS RESET** button, and **NEUTRAL LIGHT** are standard.

NEUTRAL LIGHT will light to indicate that the regulator is in the neutral position, for those regulators equipped with a circuit for this purpose.

Testing Specifications

High Voltage: All input and output terminals will withstand 1500 V ac rms to chassis or instrument ground for one minute with a leakage current not to exceed 25 mA, for all terminals to ground. Input and output circuits are electrically isolated from each other, from other circuits and from ground.

Surge Withstand Capability: All input and output circuits are protected against system transients. Units pass all requirements of ANSI/IEEE C.37.90.1-1989 defining surge withstand capability.

Radiated Electromagnetic Withstand Capability: All units are protected against electromagnetic radiated interference from portable communications transceivers.

Environmental

Temperature Range: Functionality is maintained from -40° to $+85^{\circ}$ C.

Humidity: Functionality is maintained under 95% relative humidity (non-condensing).

Fungus Resistance: A conformal printed circuit board coating inhibits fungus growth.

Physical

Size with M-2001 Series Digital Tapchanger Control: 15.38" high x 10.45" wide x 5.125" deep
(39.07 cm x 26.54 cm x 13.02 cm)

Approximate Weight: 3 lbs (1.36 kg)

Approximate Shipping Weight: 8 lbs (3.63 kg)

Approximate Weight with M-2001 Series Digital Tapchanger Control: 7 lbs, 5 oz (3.32 kg)

Approximate Shipping Weight with M-2001 Series Digital Tapchanger Control: 14 lbs (6.4 kg)

Warranty

The M-2264B Adapter Panel is covered by a five year warranty from date of shipment.

Specification subject to change without notice.

BECKWITH ELECTRIC CO., INC.

6190 - 118th Avenue North • Largo, Florida 33773-3724 U.S.A.

PHONE (727) 544-2326 • FAX (727) 546-0121

marketing@beckwithelectric.com

www.beckwithelectric.com

ISO9001:2015

WARNING

DANGEROUS VOLTAGES, capable of causing death or serious injury, are present on the external terminals and inside the equipment. Use extreme caution and follow all safety rules when handling, testing or adjusting the equipment. However, these internal voltage levels are no greater than the voltages applied to the external terminals.

DANGER! HIGH VOLTAGE



- This sign warns that the area is connected to a dangerous high voltage, and you must never touch it.

PERSONNEL SAFETY PRECAUTIONS

The following general rules and other specific warnings throughout the manual must be followed during application, test or repair of this equipment. Failure to do so will violate standards for safety in the design, manufacture, and intended use of the product. Qualified personnel should be the only ones who operate and maintain this equipment. Beckwith Electric Co., Inc. assumes no liability for the customer's failure to comply with these requirements.



- This sign means that you should refer to the corresponding section of the operation manual for important information before proceeding.



Always Ground the Equipment

To avoid possible shock hazard, the chassis must be connected to an electrical ground. When servicing equipment in a test area, the Protective Earth Terminal must be attached to a separate ground securely by use of a tool, since it is not grounded by external connectors.

Do NOT operate in an explosive environment

Do not operate this equipment in the presence of flammable or explosive gases or fumes. To do so would risk a possible fire or explosion.

Keep away from live circuits

Operating personnel must not remove the cover or expose the printed circuit board while power is applied. In no case may components be replaced with power applied. In some instances, dangerous voltages may exist even when power is disconnected. To avoid electrical shock, always disconnect power and discharge circuits before working on the unit.

Exercise care during installation, operation, & maintenance procedures

The equipment described in this manual contains voltages high enough to cause serious injury or death. Only qualified personnel should install, operate, test, and maintain this equipment. Be sure that all personnel safety procedures are carefully followed. Exercise due care when operating or servicing alone.

Do not modify equipment

Do not perform any unauthorized modifications on this instrument. Return of the unit to a Beckwith Electric repair facility is preferred. If authorized modifications are to be attempted, be sure to follow replacement procedures carefully to assure that safety features are maintained.

PRODUCT CAUTIONS

Before attempting any test, calibration, or maintenance procedure, personnel must be completely familiar with the particular circuitry of this unit, and have an adequate understanding of field effect devices. If a component is found to be defective, always follow replacement procedures carefully to that assure safety features are maintained. Always replace components with those of equal or better quality as shown in the Parts List of the Instruction Book.

Avoid static charge

This unit contains MOS circuitry, which can be damaged by improper test or rework procedures. Care should be taken to avoid static charge on work surfaces and service personnel.

Use caution when measuring resistances

Any attempt to measure resistances between points on the printed circuit board, unless otherwise noted in the Instruction Book, is likely to cause damage to the unit.

TABLE OF CONTENTS

M-2264B ADAPTER PANEL

Application Guide

1.0	Introduction	1
1.1	Description	1
2.0	Application	2
	<i>Figure 1</i> M-2001 (Comprehensive and BASE-T) and M-2264B Panel Typical Connections with Optional Voltage Reduction and SCADA Switches	3
	<i>Figure 2</i> M-2001 (BASE-R) version and M-2264B Panel Typical Connections without Optional Voltage Reduction and SCADA Switches	4
	<i>Figure 3</i> External Connections	5
	<i>Figure 4</i> M-2264B Wiring Harness and External Connections	6
	<i>Table 1</i> Multi-step Voltage Reduction External Connections	7
	<i>Figure 5</i> Tapchanger Control and LTC Backup Control Interconnections	8
3.0	Installation	9
	<i>Figure 6</i> Outline Dimensions	9
	<i>Figure 7</i> General Electric Control in Cabinet	10
	<i>Figure 8</i> M-2001 Harness Connector	11
	<i>Figure 9</i> M-2001 V-Notch Orientation	11
	<i>Figure 10</i> M-2264B Adapter Panel and M-2001 Series Tapchanger Control in Cabinet	12
4.0	Bench Test (M-2001 Connected to M-2264B)	13
	<i>Table 2</i> Initial Settings	13
	<i>Figure 11</i> M-2264B Test Procedure External Connections (Comprehensive or BASE-T Version)	15
	<i>Figure 12</i> M-2264B Test Procedure External Connections (BASE-R Version)	16
5.0	Checkout Procedure	17
	<i>Figure 10</i> M-2264B Setup for Current Checkout Procedure	18

This Page Left Intentionally Blank

1.0 Introduction

The Beckwith Electric M-2264B Adapter Panel, used in conjunction with the M-2001 Series Digital Tapchanger Control, uses modern electronic digital design and digital processing circuitry to achieve an overall stability and resolution unattainable with electromechanical and analog design tapchanger controls. CMOS semiconductors are used throughout the design.

This application guide should be used in conjunction with the M-2001C Instruction Book for M-2001 Series applications information.

■ **NOTE:** The two thumbscrews *must be saved* from the original control.

1.1 Description

Standard Features

The M-2264B Adapter Panel, with the M-2001 Series Digital Tapchanger Control, provides a voltage control relay designed to directly replace controls for General Electric ML-32 regulators. The combination of the Tapchanger Control and Adapter Panel includes the following features:

- Voltage waveform sampling and digital processing circuitry ensure accurate rms voltage sensing in the presence of distortion on the input voltage and current.
- Control accuracy is $\pm 0.3\%$ when tested in accordance with the ANSI/IEEE C57.15.9-1999 standard over a temperature range of -30°C to $+65^{\circ}\text{C}$. The control accuracy is $\pm 0.5\%$ when tested over the full operational temperature range of -40°C to $+85^{\circ}\text{C}$.
- Input and output circuits are protected against system transients. Units pass all requirements of ANSI/IEEE C37.90.1-1989, which defines surge withstand capability. All input and output terminals will withstand 1500 V ac RMS to chassis or instrument ground for one minute with a leakage current not to exceed 25 mA, for all terminals to ground. Input and output circuits are electrically isolated from each other, from other circuits and from ground.

Control Switches

RAISE/LOWER/OFF switch allows local manual raise and lower commands to be initiated

DRAG HANDS RESET pushbutton resets the tapchanger position indicator drag hands.

AUTO/OFF/MANUAL switch allows manual operation of the control.

Status Indicators

Separate Motor Power (6A) and Voltage (1A) sensing fuses are provided with spare fuses located in their respective fuseholders.

NEUTRAL light illuminates when the regulator is in the neutral tap position.

Binding Posts

METER OUT binding posts allow reading of the input voltage when used in conjunction with the **BIAS TEST VOLTAGE** screen of the M-2001 Tapchanger Control.

2.0 Application

Typical Connections for General Electric Regulators

In general, the tapchanger motor must be operated from a different transformer than the vt used to measure regulated voltage. If this is not done, hunting at the upper band edge may result. As soon as the motor starts and before it is sealed in, the motor current can drop the voltage within the band and reset the control. Some motor seal-in schemes are fast enough to prevent this, but others are not.

A typical connections for the M-2264B are shown in Figures 1 and 2. Connections are simplified and may not show all functions required in a typical load tapchanging transformer control scheme; for example, seal-in contacts, limit switches, etc.

External Connections

Power and voltage sensing are obtained either from a common source or from independent sources having a nominal 120 V ac output. Normally, this is line-to-neutral voltage, although line-to-line voltage can also be used if recognition is made of any phase shift between the voltage and current signals when using line drop compensation.

Load current must be reduced by an appropriate auxiliary current transformer to 0.2 A “full scale” before connecting to the M-2264B current inputs. The Beckwith Electric M-0121 (5.0 A to 0.2 A) or M-0169A (5.0 A or 8.66 A to 0.2 A) Auxiliary Current Transformer can be used for this purpose.

The M-0121 can be used with Beckwith Electric Tapchanger Controls when the only burden present is the Line Drop Compensator circuit of the voltage regulating relay.

The M-0169A is used in high burden circuits, such as are found in paralleling schemes. Outputs of the auxiliary CTs are protected against overvoltage. For further information, obtain Beckwith Electric Application Note #17, “*Basic Considerations for the Application of LTC Transformers and Associated Controls.*”

The external connections for the M-2264B are made to terminal blocks TB1 and TB2 on the printed circuit board at the base of the adapter panel. The wiring harness and external connections for the M-2264B are shown in Figure 4.

Lightning Protection

▲ **CAUTION:** For proper protection against system surges, chassis ground must be connected to earth ground.

It has been determined that transient voltages in excess of 1500 V ac rms can exist on the “ground” lead normally tied to TB1-8 on the printed circuit board of the adapter panel. In the Tapchanger Controls, these voltages are suppressed by varistors which still permit the unit to pass a 1500 V ac Hi Pot test for one minute with a leakage current of approximately 15 mA, all terminals to ground.

Multiple VT grounds far apart must be avoided since a varying difference in ground voltage could add or subtract from the effective voltage and cause variation in the Tapchanger Control’s bandcenter voltage setpoint.

Neutral Light Circuit

The M-2264B is prepared for use with regulators which use a neutral light. General Electric products require that the Neutral Light terminal be grounded when the light is to be illuminated. A switch on the printed circuit board is used to select the desired configuration (Up-Neutral, Down-Hot).

To configure the Neutral Light to be illuminated when TB1-11 is grounded inside the regulator, place the **S1** toggle switch (located on the upper right hand corner of the adapter panel printed circuit board, see Figure 4) in the “Up” (Neutral) position.

Non-Sequential Operation (N/A for BASE-R Version)

▲ **CAUTION:** Voltage applied through dry contacts to actuate non-sequential input *must* be +12 V dc obtained from pin TB2-28 of the M-2264B adapter panel. If an M-0293 analog-version tapchanger control had previously been installed, the wiring harness must be reconfigured to remove the 120 V ac “wetting” voltage obtained from TB1-9. Carefully examine the contacts of these functions to remove 120 V ac wetting voltages.

The operation of the M-2264B can be interrupted during tapchanger operation by applying the “wetting” voltage of terminal TB2-28 to TB1-1 (timer reset for non-sequential operation input) on the printed circuit board through an external contact. This causes the output to de-energize and reinitialize the time delay circuit when the reset signal is removed. This function can be used to cause the LTC transformer, if so equipped, to wait for the unit to time out between tapchanges.

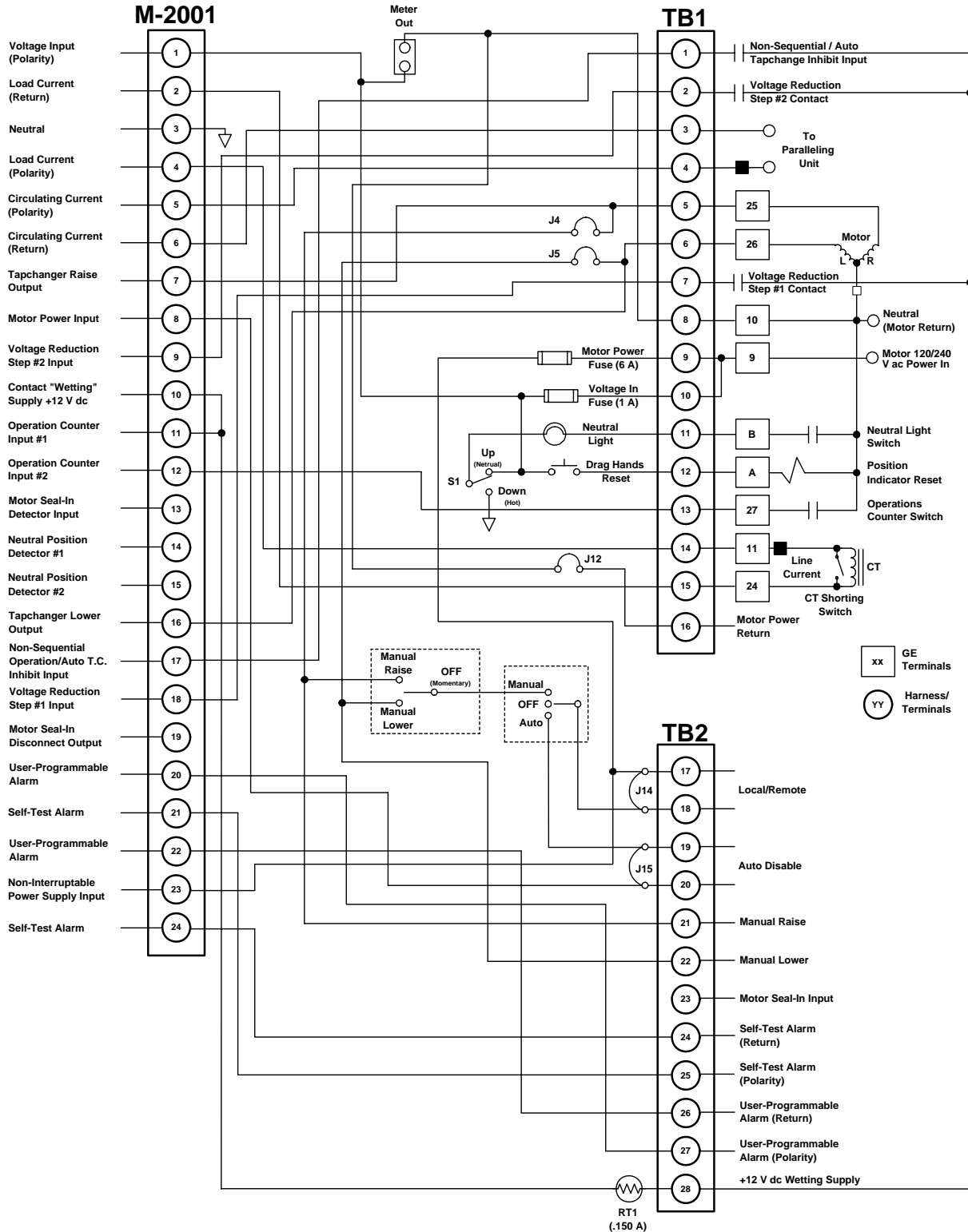

Figure 1 M-2001 (Comprehensive and BASE-T) and M-2264B Panel Typical Connections

M-2264B Application Guide

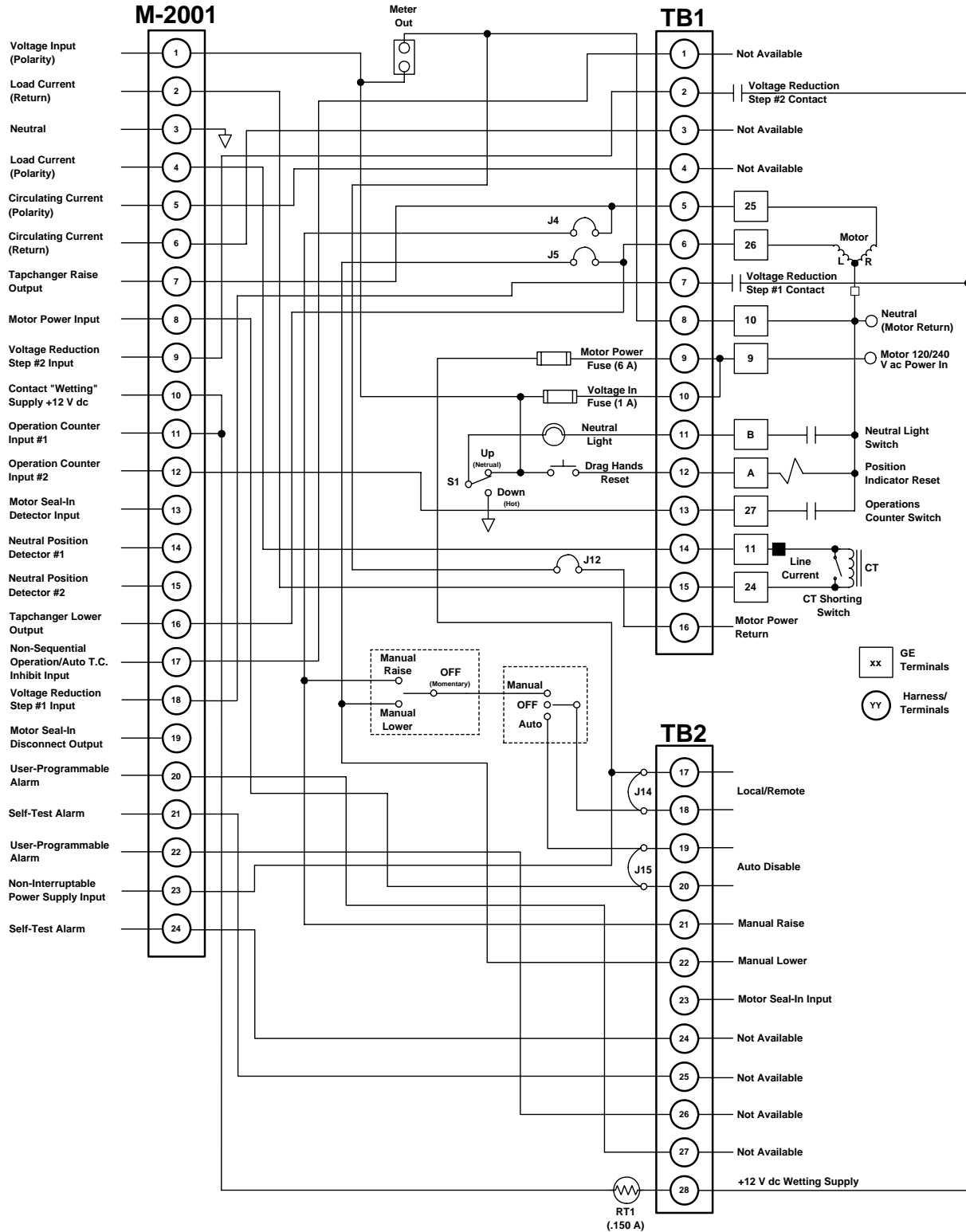
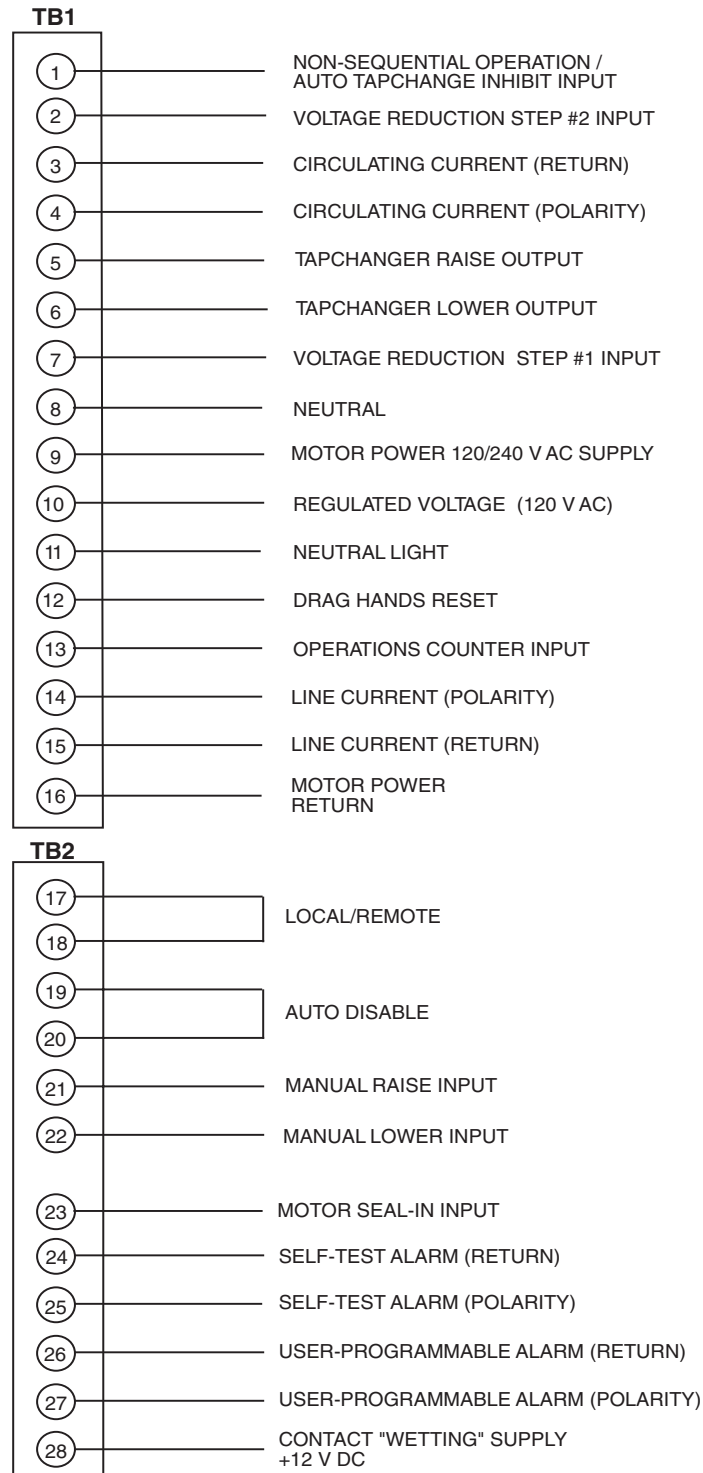
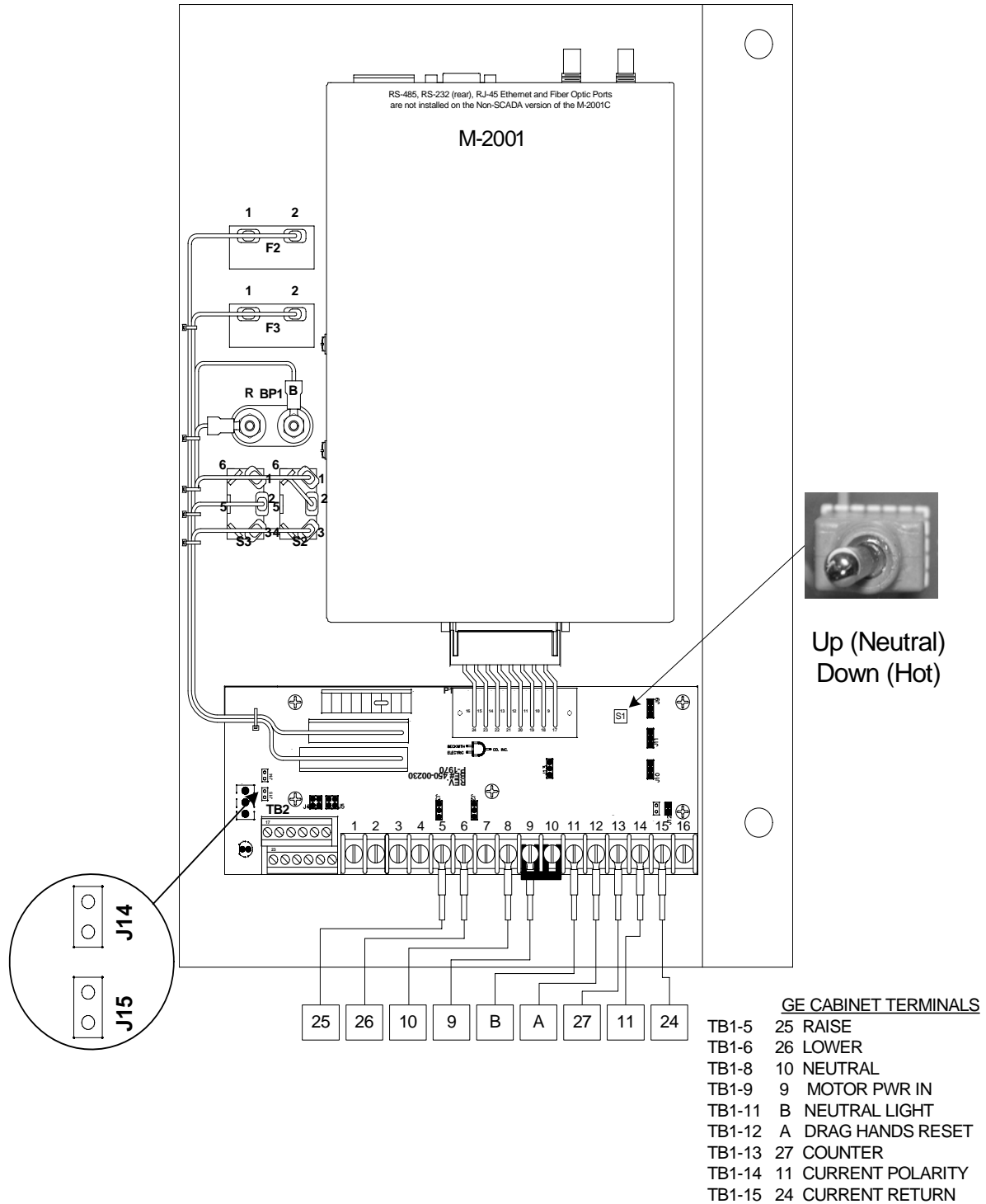

Figure 2 M-2001 (BASE-R) version and M-2264B Panel Typical Connections



● WARNING: Open CT secondary will result in high voltage at CT terminals. Death, severe injury or damage to equipment can occur. Do not operate with CT secondary open. Short circuit or apply burden at CT secondary during operation.

Figure 3 External Connections



■ **NOTE:** The self-test alarm and user-programmable alarm contacts are shown in the de-energized state (no voltage applied). The self-test alarm contacts open after the M-2001 passes the self-test; the user-programmable alarm contacts close when an alarm is recognized.

● **WARNING:** In no case should the line current circuit be interrupted with the regulator or transformer energized. Do not remove auxiliary current transformers without shorting the current inputs. Death or severe electrical shock can occur.

Figure 4 M-2264B Wiring Harness and External Connections

Auto Disable Input

To disable automatic operation of the M-2264B, remove Jumper #15 (See Figure 4, for location) on the printed circuit board.

If SCADA is used to enable and disable this function, a contact rated at 6 A minimum can be connected between the terminals.

Auto disable may also be accomplished by closing a contact between pin TB1-1 and TB2-28.

Operations Counter Input

▲ **CAUTION:** Do not apply either +12 V dc or 120 V ac to this terminal.

An operations count is registered by momentarily grounding TB1-13 through an external dry contact from the load tapchanger. The input is level-sensitive. Make sure that any “wetting” voltages are removed from the counter contacts before installing the M-2264B Adapter Panel/M-2001 Series Digital Tapchanger Control.

Local/Remote Input

Removing Jumper #14 (See Figure 4, for location) prohibits M-2001 operation by disabling the automatic raise and lower outputs and also by disabling the M-2264B Adapter Panel’s manual **RAISE/OFF/LOWER** toggle switch. Removing this jumper does *not* disable the SCADA-supplied motor voltage input to the manual raise/manual lower contacts on the adapter panel.

Multi-Step Voltage Reduction

▲ **CAUTION:** Voltage applied through dry contacts to actuate Voltage Reduction Steps 1, 2, and 3 *must* be +12 V dc obtained from pin TB2-28 of the M-2264B adapter panel. If an M-0293 analog-version tapchanger control had previously been installed, the wiring harness must be reconfigured to remove the 120 V ac “wetting” voltage obtained from TB1-9. Carefully examine the contacts of these functions to remove 120 V ac wetting voltages.

On the M-2264B, TB1-2 and TB1-7 on the printed circuit board are used together to provide up to three levels of voltage reduction. The external connections to achieve these steps are shown in Table 1 and Figure 4. Voltage reduction amounts are set within the M-2001 Series Digital Tapchanger Control software.

Paralleling

See M-2001C Instruction Book, Section 4.9, Parallel Operation.

Voltage Reduction Setpoint: Multiplier Range	Apply "Wetting Voltage" from TB2-28 to Terminal #
Voltage Reduction Setpoint #1: 0 to 10%	TB1-7
Voltage Reduction Setpoint #2: 0 to 10%	TB1-2
Voltage Reduction Setpoint #3: 0 to 10%	TB1-7 and TB1-2

Table 1 Multi-Step Voltage Reduction External Connections

Use of the M-0329B LTC Backup Control with the Tapchanger Control

The M-0329B is a single-phase, solid-state backup control that prevents a defective tapchanger control from running the voltage outside the upper and lower voltage limits. The Block Raise and Block Lower voltage levels are set by accurately calibrated dials.

The M-0329B LTC Backup Control is connected as a two terminal device to the voltage transformer. Figure 7 shows the typical interconnection of the two devices with motor auxiliary relays.

The M-0329B Instruction Book is available on request and gives added details. Please refer to the M-0329B Instruction Book for complete ordering information.

The **BANDCENTER** and **BANDWIDTH** dials on the M-0329B LTC Backup Control should be set so that the Block Lower limit is a small amount (approximately 2 V) below the lower band limit of the Tapchanger Control, and the Block Raise limit is a similar amount above the upper limit if line drop compensation is *not* used.

If line drop compensation is used, the M-0329B Block Raise limit should be set at the maximum voltage desired at the transformer secondary under full load.

The M-0329B LTC Backup Control also includes a deadband or runback function that regulates the maximum voltage from the transformer. This “Lower” function operates slightly above the Block Raise limit and is connected to force the tapchanger to lower the voltage if the upper limit is exceeded.

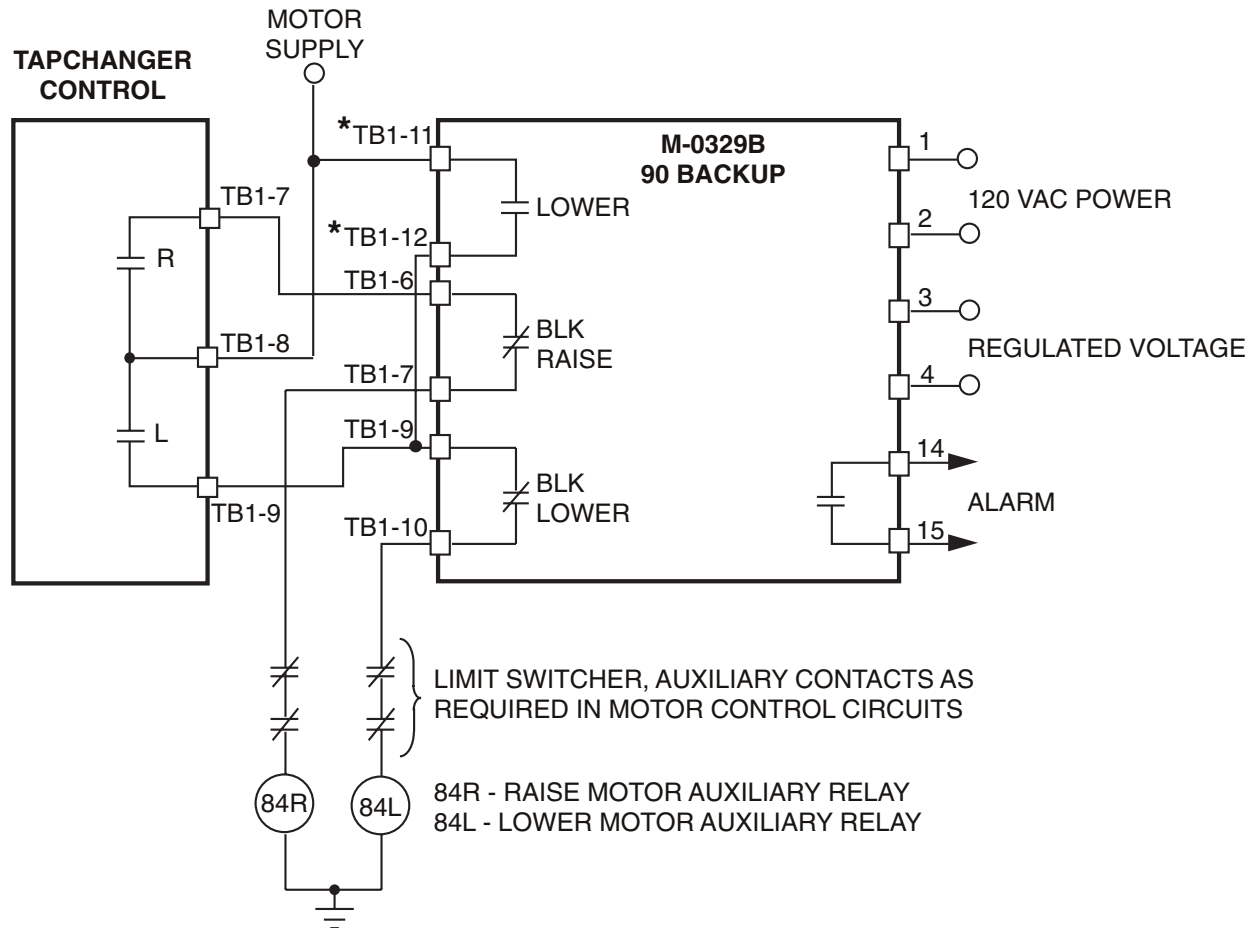

*■ **NOTE:** If first customer protection is not required, delete these connections.

Figure 5 Tapchanger Control and LTC Backup Control Interconnections

3.0 Installation

The M-2264B has two mounting holes on the left side that allow easy mounting into the existing General Electric control cabinet. Refer to Figure 6, below.

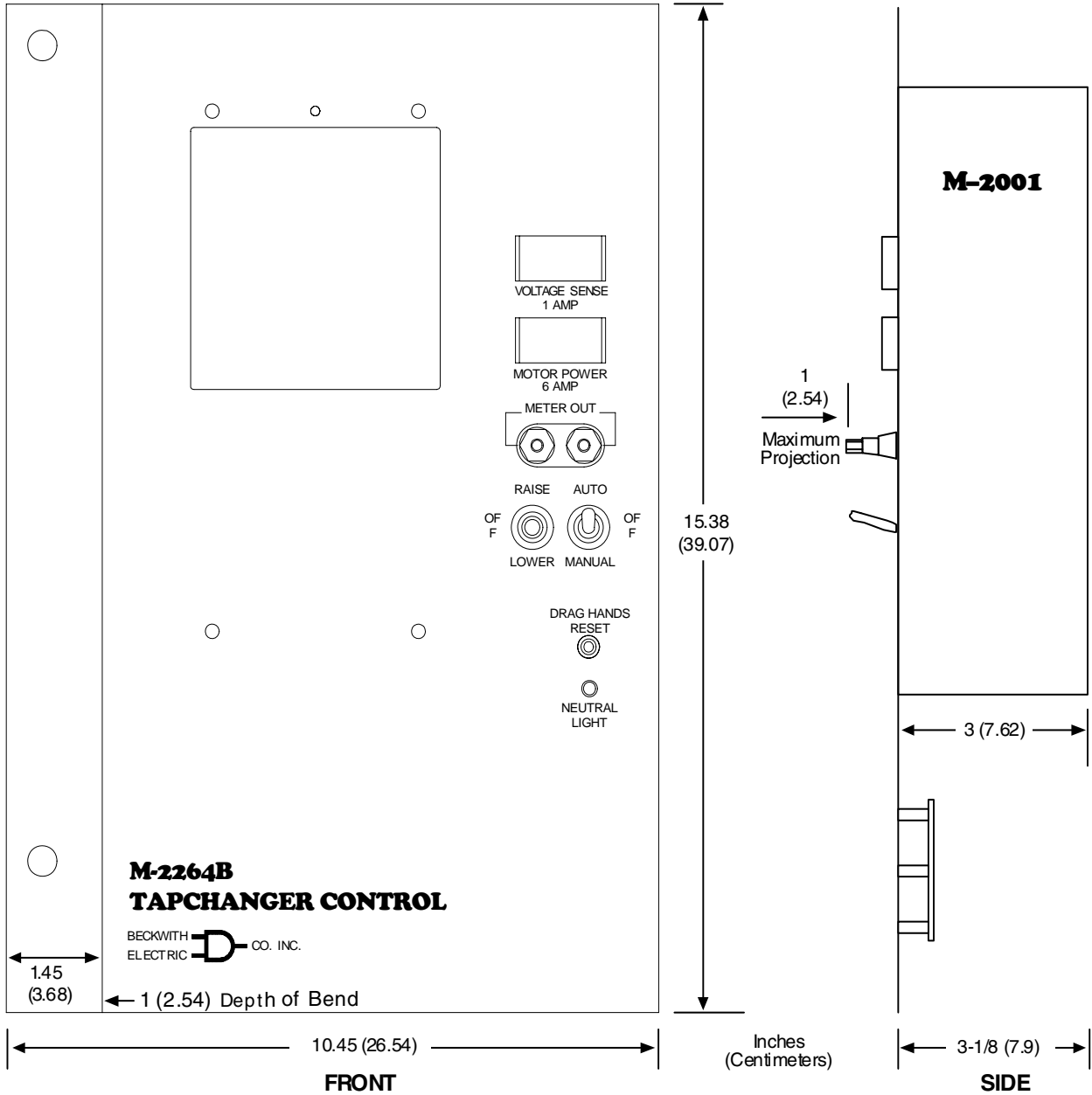

Figure 6 Outline Dimensions

Removal of the General Electric Control

Refer to Figure 7.

1. Open the cabinet door of General Electric control.
2. Remove the two thumbscrews on the left side of the control panel.
3. Remove the control panel from the cabinet.
4. Remove all connections from the wiring harness of the control panel to the terminal block.

■ **NOTE:** The two thumbscrews *must be saved* from the original control.

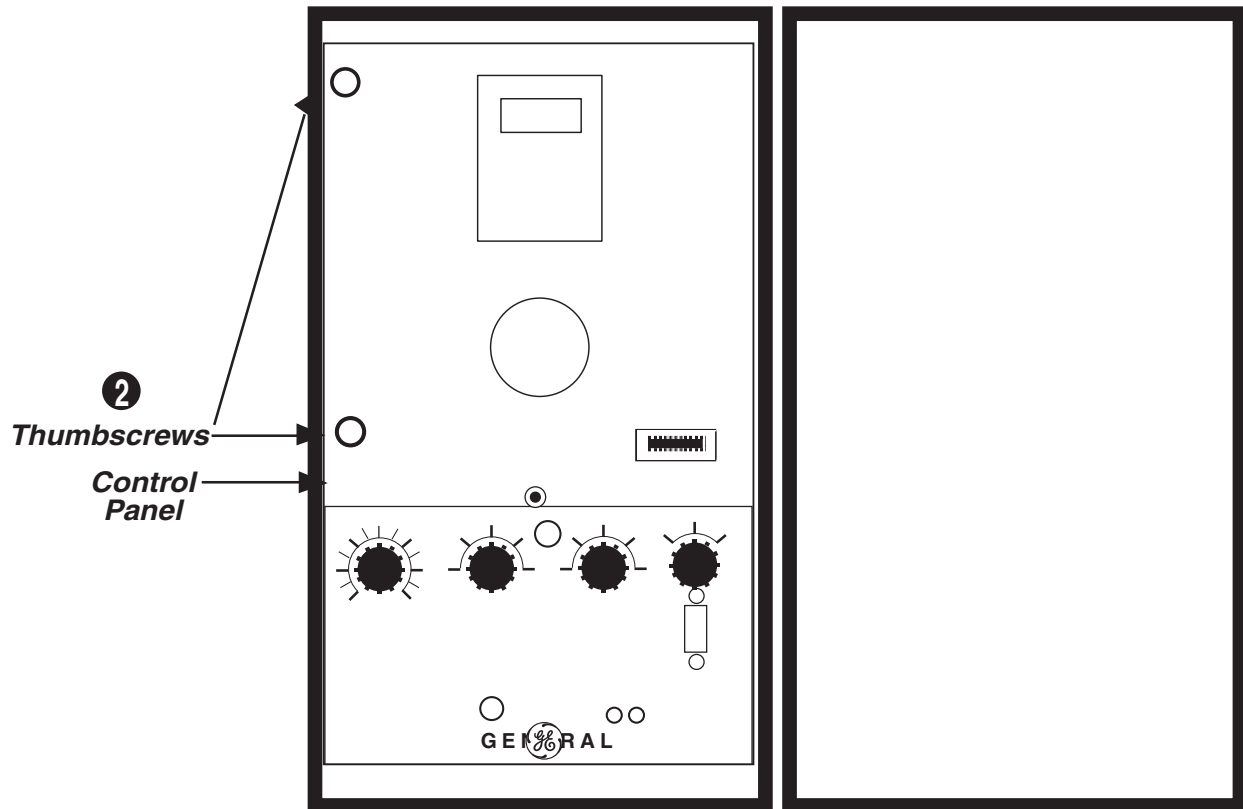

Figure 7 General Electric Control in Cabinet

Installing the M-22264B/M-2001

1. Mount the M-2001 Series Digital Tapchanger Control to the back of the M-2264B Adapter Panel and secure with the four screws provided. The four screws are shipped in a drawstring bag which is attached to the adapter panel.

■ **NOTE:** The blue connector is keyed by a “V” notch in the middle to prevent incorrect mating (Figure 8). Check location of the key before plugging connector into the M-2001.

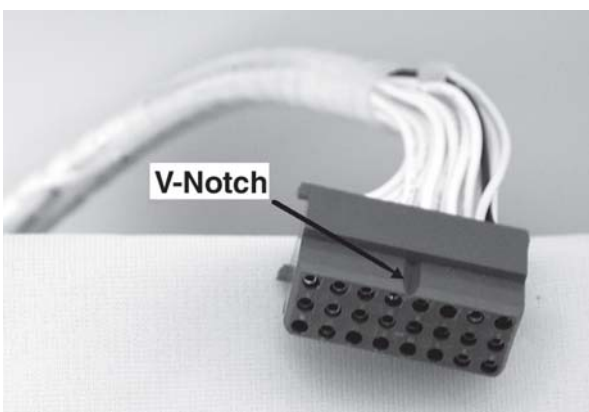

Figure 8 M-2001 Harness Connector

2. Plug the blue connector of the M-2264B harness into the bottom of the M-2001.

If desired, bench testing may be performed as described in Section 4.0, Bench Test.

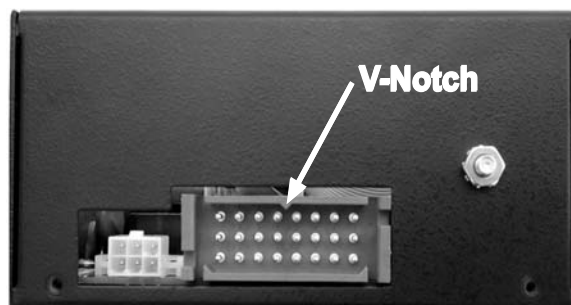

Figure 9 M-2001 V-Notch Orientation

3. Place the M-2264B panel in the enclosure and install the two thumb screws saved from the original control (Figure 10).
4. Connect the M-2293B wiring harness to the terminal blocks (refer to Figure 4).
5. Close the cabinet door.
6. Set the toggle switch to the **Manual** position.
7. Set up the desired configuration and settings on the M-2001. See M-2001 Instruction Book Chapter 4, **Configuration**.
8. Verify manual operation of the unit.
9. Set the toggle switch to the **Auto** position and verify automatic operation.

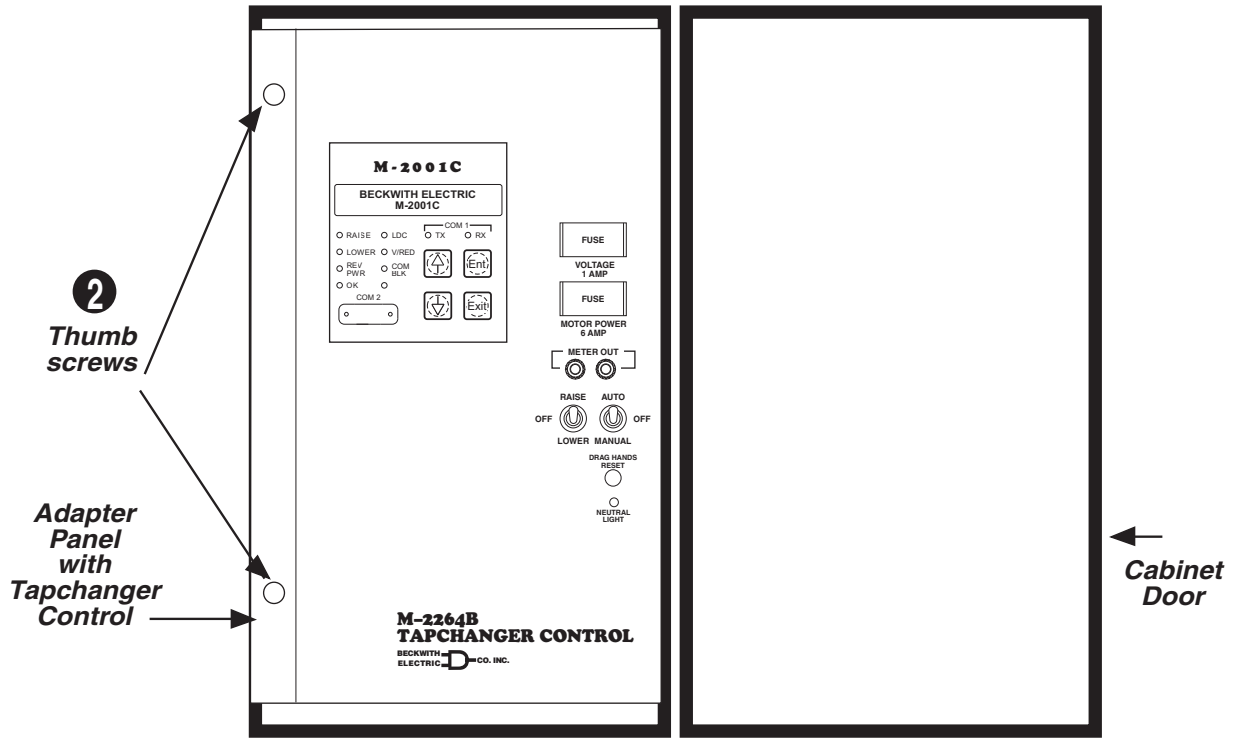

Figure 10 M-2264B Adapter Panel and M-2001 Series Tapchanger Control in Cabinet

4.0 Bench Test (M-2001 Connected to M-2264B)

■ **NOTE:** This test assumes that the M-2001 Tapchanger Control is connected to the M-2264B Adapter Panel.

Test Equipment

- 0–200 MA current supply with phase angle settings of 0° to +90°.

▲ **CAUTION:** The current input to the M-2001 is rated at 0.2 A continuous, 0.4 A for two hours, and 4.0 A for 1 second.

- 90–145 V ac voltage source at 60 Hz
- High impedance true RMS voltmeter with accuracy on ac of at least $\pm 0.2\%$ of reading
- Accurate stop watch

Setup

1. Make electrical connections as follows:
 - a. If testing an M-2001 Series Tapchanger Control other than a M-2001C BASE-R Version, then make electrical setup connections as described in Figure 11, M-2264B (Comprehensive or BASE-T Version) Test Procedure External Connections.
 - b. If testing a BASE-R M-2001C then make electrical setup connections as described in Figure 12, M-2264B (BASE-R Version) Test Procedure External Connections.

■ **NOTE:** Refer to the M-2001 Instruction Book Appendix A, Figures A-1 through A-13, for the locations of screens within the software.

■ **NOTE:** There is a one-second delay between the out-of-band condition and panel LED indication.

2. Enter initial M-2001 settings as indicated in Table 2, Initial Settings.

FUNCTION	INITIAL SETTING
Bandcenter	120.0 V
Bandwidth	2.0 V
LDC Resistance	0.0 V
LDC Reactance	0.0 V
Paralleling	N/A For BASE-R Version Circulating Current Method
Block Raise	135.0 V
Block Lower	105.0 V
Deadband	2.0 V
Time Delay	5.0 Seconds

Table 2 Initial Settings

Procedure

▲ **CAUTION:** Do not reverse the ground and hot wires when connecting an external source.

1. Apply 120 V ac from the power source.
2. The display of the M-2001 will automatically advance to the Local Voltage screen.
3. Increase voltage to 121.2. The **LOWER** LED should illuminate.
4. Decrease voltage to 118.8. The **RAISE** LED should illuminate.
5. Set the input voltage to 120.0 V ac, then wait for the **RAISE** and **LOWER** LEDs to extinguish.
6. Increase voltage to 122.0 V ac, then start timing when the voltage passes 121.0 V ac.
7. Stop timing when the lamp connected to the Lower output illuminates (should be approximately 5 seconds).

Resistance

1. Apply 100.0 mA in-phase current to TB1-14 (load current-polarity) and TB1-15 (load current-return) of the Adapter Panel.
2. Set S_1 to LDC and S_2 to I_R (Figure 11, or Figure 12, for BASE-R version).
3. Set LDC Resistance to 24.0 V. The **RAISE** LED should illuminate.
4. Increase input voltage to 132.0 V ac. The **RAISE** and **LOWER** LEDs should be extinguished.
5. Set LDC Resistance to -24.0 V. The **LOWER** LED should illuminate.
6. Decrease input voltage to 108.0 V ac. The **RAISE** and **LOWER** LEDs should be extinguished.
7. Set LDC Resistance to 0.0 V.

Reactance

1. Apply 100.0 mA 90° leading current to TB1-14 (load current-polarity) and TB1-15 (load current-return) of the adapter panel.
2. Set S_1 to LDC and S_2 to I_L (Figure 11, or Figure 12, for BASE-R version).
3. Set LDC Reactance to 24.0 V. The **LOWER** LED should illuminate.
4. Decrease input voltage to 108.0 V ac. The **RAISE** and **LOWER** LEDs should be extinguished.
5. Set LDC Reactance to -24.0 V. The **RAISE** LED should illuminate.
6. Increase input voltage to 132.0 V ac. The **RAISE** and **LOWER** LEDs should be extinguished.
7. Set LDC Reactance to 0.0 V.

Paralleling (N/A For BASE-R Version)

1. Apply 100.0 mA 90° leading current to TB1-4 (circulating current-polarity) and TB1-3 (circulating current-return) of the adapter panel. The **LOWER** LED should illuminate.
2. Decrease voltage to 108.0 V ac. The **RAISE** and **LOWER** LEDs should be extinguished.
3. Turn off the current input.

Drag Hands Reset

1. Connect a lamp or ac relay from TB1-12 (drag hands reset) to TB1-8 (neutral) of the adapter panel.
2. Press the **DRAG HAND RESET** switch, the connected lamp or ac relay should illuminate/activate.

Counter/Neutral Light/Tap Position

1. Set the M-2001 Series Digital Tapchanger Control to display the Operations Count screen.
2. Verify counter operation by connecting a switch between TB1-13 (operations counter input) and TB1-8 (neutral) of the adapter panel.
3. Lower the input voltage until the **RAISE** LED illuminates.
4. Allow the delay timer to time out, then activate the switch between TB1-13 (operations counter input) and TB1-8 (neutral). The tap position should change.
5. Place a jumper between TB1-11 (neutral light) and TB1-8 (neutral).
6. Set the neutral light switch S_1 , located on the adapter panel printed-circuit board (see Figure 4), to the toggle "Up" position. The neutral light on the adapter panel should illuminate, and the tap position should return to "0 Neutral".
7. Remove the jumper placed between TB1-11 and TB1-8.

Block Raise/Block Lower/Dead Band

1. Set Block Raise to 126.0 V.
2. Set Block Lower to 114.0 V.
3. Set the M-2001 Series Digital Tapchanger Control to display the Bias Voltage screen.
4. Press **ENT**.

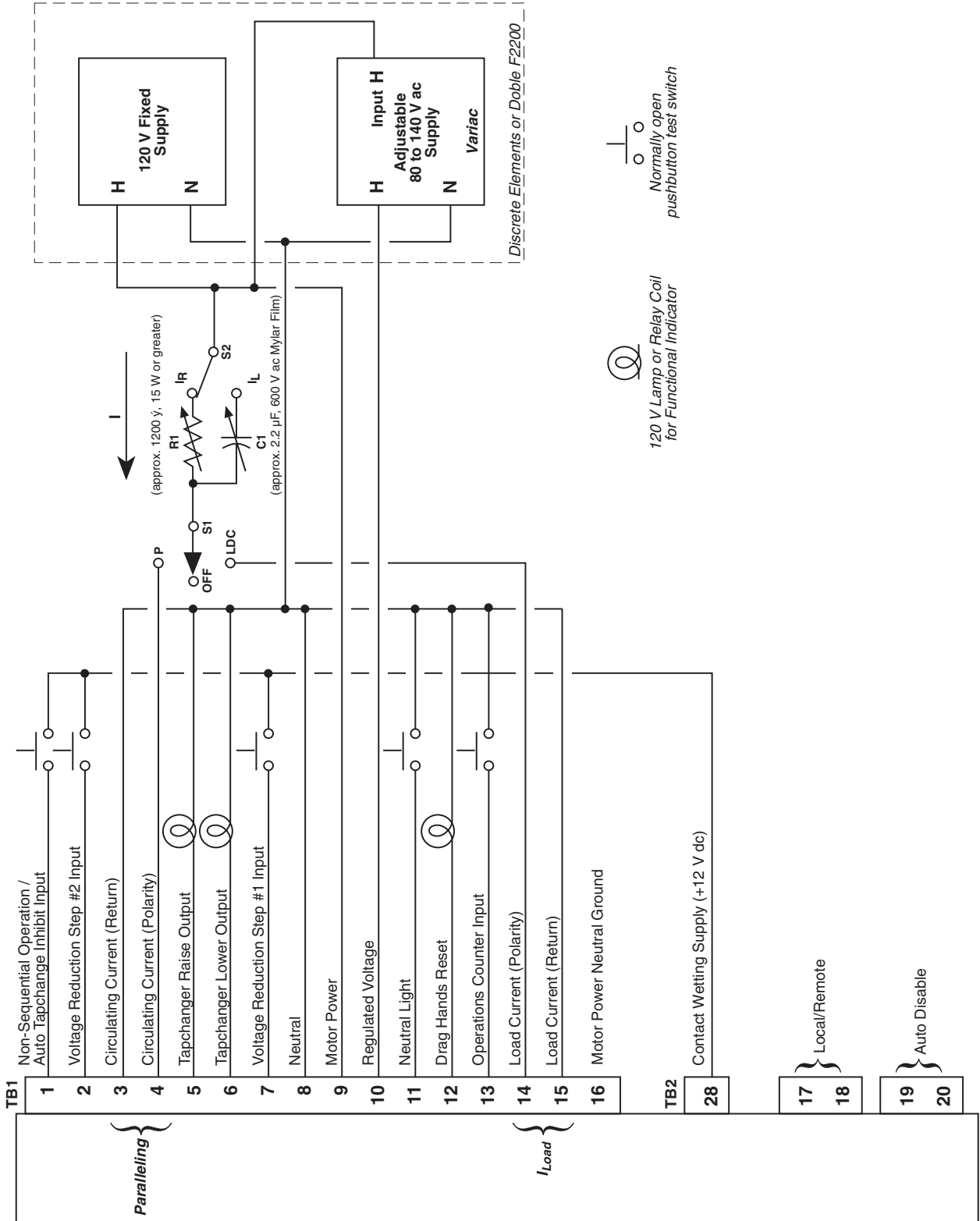

Figure 11 M-2264B Test Procedure External Connections (Comprehensive or BASE-T Version)

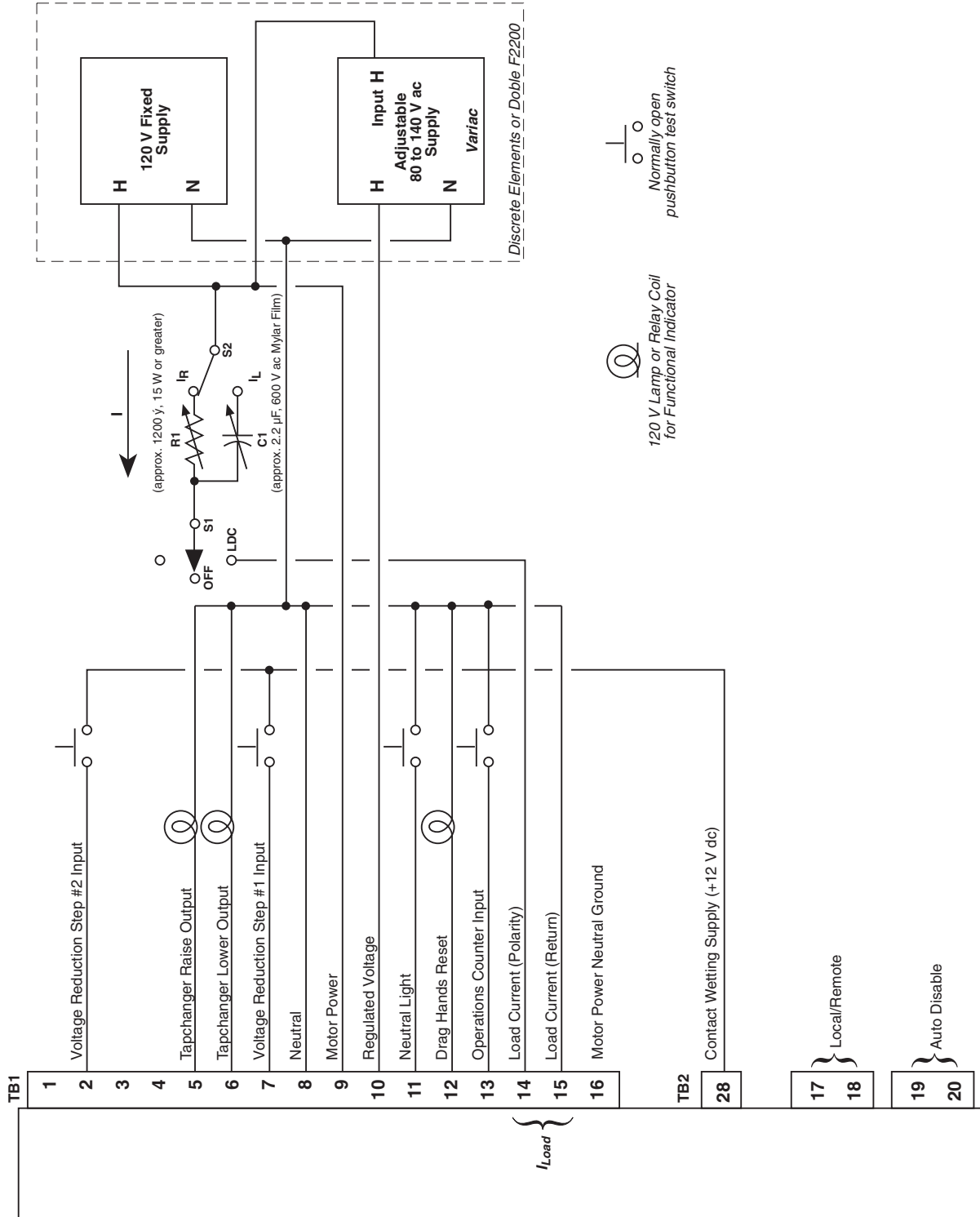

Figure 12 M-2264B Test Procedure External Connections (BASE-R Version)

5. Increase voltage to 126.5 V. **BR** should be displayed on the screen.
6. Increase voltage to 128.5 V. **FL** should be displayed on the screen.
7. Decrease voltage to 113.5 V. **BL** should be displayed on the screen.

—Bench Test Complete—

Basic Operational Test (M-2264B Connected to M-2001)

1. Apply 120.0 V ac to TB1-9 (motor power) and TB1-10 (regulated voltage) of the adapter panel.
2. Connect neutral to TB1-8 (neutral).
3. Verify local voltage equals input voltage ± 0.3 V.
4. Apply 100.0 mA in-phase current to TB1-14 (load current-polarity) and TB1-15 (load current-return) of the adapter panel. Verify Control Load I equals 100 mA and Power Factor equals 1.0 ± 0.02 .
5. Apply 100.0 mA 90° leading current to TB1-4 (circulating current-polarity) and TB1-3 (circulating current-return) of the adapter panel.
6. Verify Control Circ I equals 100.0 mA ± 2 mA.
7. Verify the **▲** or **▼** and **ENT** pushbuttons function properly.

—Basic Operational Test Complete—

In-Service Test

1. Set the M-2001 Tapchanger Control to display Bias Voltage screen.
2. Press **ENT**.
3. Use the **▲** or **▼** pushbuttons to cause **RAISE** and **LOWER** outputs.

—In-Service Test Complete—

Return unit to desired settings

5.0 Checkout Procedure

All M-2001 series units are fully calibrated at the factory. There is no need to recalibrate the units before initial installation.

■ **NOTE:** This test assumes that the M-2001 Tapchanger Control is connected to the M-2264B Adapter Panel.

Pre-Test Conditions

1. Place the **AUTO/OFF/MANUAL** switch in the **OFF** position.
2. Verify that the **MOTOR POWER** and **VOLTAGE** fuses are correctly sized and have not blown.

Power

1. Remove any external connections between TB1-9 (Motor Power) and TB1-10 (Regulated Voltage), which are located on the adapter panel printed circuit board.
2. Remove any voltage applied to TB1-9 externally.
3. Apply a nominal 120 V ac test voltage source between TB1-10 (hot) and TB1-8 (neutral).
4. Using a voltmeter, verify that the voltage applied to TB1-10 is nominal 120.0 V ac with respect to TB1-8.

● **WARNING:** Death or electrical shock can occur if a voltage source is connected at the **METER OUT** test terminal. Applying a voltage source may energize the regulator or transformer to a high voltage through the voltage transformer.

▲ **CAUTION:** Do not reverse the ground and hot wires when connecting an external source.

5. Apply motor power to TB1-9 (hot) and TB1-8 (neutral).
6. Place the **AUTO/OFF/MANUAL** switch in the **MANUAL** position.
7. Using the **RAISE/OFF/LOWER** switch, verify that the motor runs in the proper direction when the switch is placed in the **RAISE** and **LOWER** positions.
8. Set the **AUTO/OFF/MANUAL** switch to the **AUTO** position.

9. Refer to M-2001 Instruction Book Chapter 3, **Setting the Control** for setup information.

Load Current CT

● **WARNING:** In no case should the load current circuit be interrupted with the regulator or transformer energized.

● **WARNING:** Do not remove auxiliary current transformers without shorting the current inputs. Death or severe electrical shock can occur.

1. Short the line drop compensator circuit by placing a shorting device of adequate capacity, across the LDC-CT secondary (See Figure 13).
2. Determine if the M-2001C being tested is a BASE-R version and proceed as follows:
 - a. If the M-2001C being tested is a BASE-R version, then go to Step 3.
 - b. If the M-2001C being tested is *not* a BASE-R version, then short the circulating current paralleling input for the load current check by placing a shorting device of adequate capacity across TB1-3 and TB1-4.

3. Connect an ammeter (set to the 200 mA range) between the polarity input and TB1-14.
4. Open the load current shorting device.
5. With a known load on the transformer or regulator, measure the current in the load current circuit.
6. Verify that the current measured in Step 5 is correct for 0.2 A full load.

LDC

1. Replace the shorting device across the load current input and remove the ammeter.
2. Reconnect polarity to the unit, then remove the installed shorting devices. The **LINE DROP COMPENSATION** will be activated.

Verify correct CT polarity by incorporating sufficient +R compensation. The regulator should time out and run to raise the output voltage.

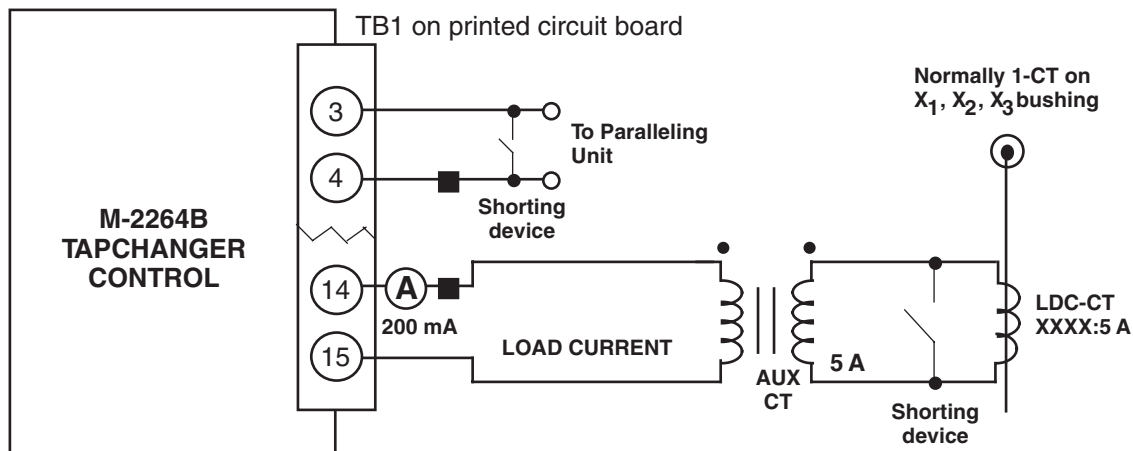

Figure 13 M-2264B Setup for Current Checkout Procedure

Patent

The units described in this manual are covered by U.S. Patents, with other patents pending.

Buyer shall hold harmless and indemnify the Seller, its directors, officers, agents, and employees from any and all costs and expense, damage or loss, resulting from any alleged infringement of United States Letters Patent or rights accruing therefrom or trademarks, whether federal, state, or common law, arising from the Seller's compliance with Buyer's designs, specifications, or instructions.

Warranty

Seller hereby warrants that the goods which are the subject matter of this contract will be manufactured in a good workmanlike manner and all materials used herein will be new and reasonably suitable for the equipment. Seller warrants that if, during a period of five years from date of shipment of the equipment, the equipment rendered shall be found by the Buyer to be faulty or shall fail to perform in accordance with Seller's specifications of the product, Seller shall at his expense correct the same, provided, however, that Buyers shall ship the equipment prepaid to Seller's facility. The Seller's responsibility hereunder shall be limited to replacement value of the equipment furnished under this contract.

Seller makes no warranties expressed or implied other than those set out above. Seller specifically excludes the implied warranties of merchantability and fitness for a particular purpose. There are no warranties which extend beyond the description contained herein. In no event shall Seller be liable for consequential, exemplary, or punitive damages of whatever nature.

Any equipment returned for repair must be sent with transportation charges prepaid. The equipment must remain the property of the Buyer. The aforementioned warranties are void if the value of the unit is invoiced to the Seller at the time of return.

Indemnification

The Seller shall not be liable for any property damages whatsoever or for any loss or damage arising out of, connected with, or resulting from this contract, or from the performance or breach thereof, or from all services covered by or furnished under this contract.

In no event shall the Seller be liable for special, incidental, exemplary, or consequential damages, including but not limited to, loss of profits or revenue, loss of use of the equipment or any associated equipment, cost of capital, cost of purchased power, cost of substitute equipment, facilities or services, downtime costs, or claims or damages of customers or employees of the Buyer for such damages, regardless of whether said claim or damages is based on contract, warranty, tort including negligence, or otherwise.

Under no circumstances shall the Seller be liable for any personal injury whatsoever.

It is agreed that when the equipment furnished hereunder are to be used or performed in connection with any nuclear installation, facility, or activity, Seller shall have no liability for any nuclear damage, personal injury, property damage, or nuclear contamination to any property located at or near the site of the nuclear facility. Buyer agrees to indemnify and hold harmless the Seller against any and all liability associated therewith whatsoever whether based on contract, tort, or otherwise. Nuclear installation or facility means any nuclear reactor and includes the site on which any of the foregoing is located, all operations conducted on such site, and all premises used for such operations.

Notice:

Any illustrations and descriptions by Beckwith Electric Co., Inc. are for the sole purpose of identification.

The drawings and/or specifications enclosed herein are the proprietary property of Beckwith Electric Co., Inc., and are issued in strict confidence; therefore, shall not be used as a basis of reproduction of the apparatus described therein without written permission of Beckwith Electric Co., Inc.

No illustration or description contained herein shall be construed as an express warranty of affirmation, promise, description, or sample, and any and all such express warranties are specifically excluded nor shall such illustration or description imply a warranty that the product is merchantable or fit for a particular purpose. There shall be no warranties which extend beyond those contained in the Beckwith Electric Co., Inc. terms of sale.

This Page Left Intentionally Blank

BECKWITH ELECTRIC CO., INC.

6190 - 118th Avenue North • Largo, Florida 33773-3724 U.S.A.

PHONE (727) 544-2326 • FAX (727) 546-0121

marketing@beckwithelectric.com

www.beckwithelectric.com

ISO9001:2015