



Application Guide

**M-2286
Adapter Panel**

**BECKWITH
ELECTRIC** 



A proud member of the Hubbell family.

TRADEMARKS

All brand or product names referenced in this document may be trademarks or registered trademarks of their respective holders.

The content of this Instruction Book is provided for informational use only and is subject to change without notice. Beckwith Electric has approved only the English version of this document.

Adapter Panel M-2286

**Adapts M-2001 Series Digital Tapchanger Control
to Replace Westinghouse MS and TM LTC
Transformer Control Panels**

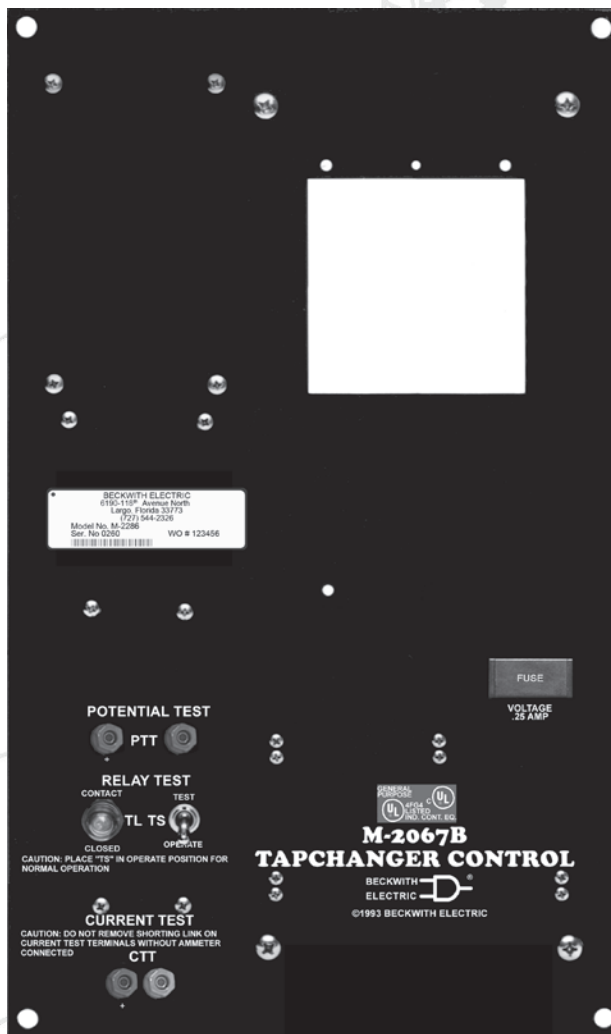

- **Connects easily to the M-2001 Series Digital Tapchanger Control using mounting screws and 24-pin connector**
- **Replaces MS and TM panels, fits directly into existing control cabinet cutout and quickly plugs into existing connectors**
- **Provides built-in CT shorting protection when the M-2001 Series Digital Tapchanger Control is removed**

The M-2286 is a replacement panel which, when combined with the M-2001 Series Digital Tapchanger Control, provides convenient direct replacement for Westinghouse MS and TM Control Panels. The M-2286 mounts directly into the existing cutout in the control cabinet, and includes the M-2067B Adapter Panel with a voltage fuse and two terminal blocks on the rear for external connections.

The M-2286 also includes an M-0169A Auxiliary Current Transformer that contains sockets for existing MS and TM connectors.

Interface

External connections are made to two terminal blocks located on the rear of the M-2067B Adapter Panel. An additional terminal block provides access to auxiliary functions, including self-test alarm, user-programmable alarm, manual raise/lower and operations counter.

Features

Binding posts on the front panel allow easy connections for test procedures.

A relay **TEST/OPERATE** toggle switch with **INDICATOR LIGHT** for **CONTACT CLOSURE**; and a cam switch auxiliary relay (used only for non-sequential operation) are standard.

Testing Specifications

High Voltage: All input and output terminals will withstand 1500 Vac rms to chassis or instrument ground for one minute with a leakage current not to exceed 25 mA, for all terminals to ground. Input and output circuits are electrically isolated from each other, from other circuits and from ground.

Surge Withstand Capability: All input and output circuits are protected against system transients. Units pass all requirements of ANSI/IEEE C.37.90.1-1989 defining surge withstand capability.

Radiated Electromagnetic Withstand Capability: All units are protected against electromagnetic radiated interference from portable communications transceivers.

Environmental

Temperature Range: Functionality is maintained from -40° to +85° C.

Humidity: Functionality is maintained under 95% relative humidity (non-condensing).

Fungus Resistance: A conformal printed circuit board coating inhibits fungus growth.

Physical

Size: 19-3/8" high x 11-3/8" wide (49.21 cm x 28.89 cm)

Depth: with M-2001 Series Digital Tapchanger Control, 3" (7.62 cm); with M-0169A Auxiliary Current Transformer, 3-3/8" (8.57 cm)

Approximate Weight: 7 lbs (3.18 kg)

Approximate Shipping Weight: 10 lbs (4.54 kg)

Approximate Weight with M-2001 Series Digital Tapchanger Control: 11 lbs, 5 oz (5.13 kg)

Approximate Shipping Weight with M-2001 Series Digital Tapchanger Control: 16 lbs (7.26 kg)

Warranty

The M-2286 Adapter Panel is covered by a five year warranty from date of shipment.

Specification subject to change without notice.

BECKWITH ELECTRIC

6190 118th Avenue North • Largo, Florida 33773-3724 U.S.A.

PHONE (727) 544-2326

beckwithelectricssupport@hubbell.com

www.beckwithelectric.com

ISO 9001:2015



A proud member of the Hubbell family.

WARNING

DANGEROUS VOLTAGES, capable of causing death or serious injury, are present on the external terminals and inside the equipment. Use extreme caution and follow all safety rules when handling, testing or adjusting the equipment. However, these internal voltage levels are no greater than the voltages applied to the external terminals.

DANGER! HIGH VOLTAGE



- This sign warns that the area is connected to a dangerous high voltage, and you must never touch it.

PERSONNEL SAFETY PRECAUTIONS

The following general rules and other specific warnings throughout the manual must be followed during application, test or repair of this equipment. Failure to do so will violate standards for safety in the design, manufacture, and intended use of the product. Qualified personnel should be the only ones who operate and maintain this equipment. Beckwith Electric assumes no liability for the customer's failure to comply with these requirements.



- This sign means that you should refer to the corresponding section of the operation manual for important information before proceeding.



Always Ground the Equipment

To avoid possible shock hazard, the chassis must be connected to an electrical ground. When servicing equipment in a test area, the Protective Earth Terminal must be attached to a separate ground securely by use of a tool, since it is not grounded by external connectors.

Do NOT operate in an explosive environment

Do not operate this equipment in the presence of flammable or explosive gases or fumes. To do so would risk a possible fire or explosion.

Keep away from live circuits

Operating personnel must not remove the cover or expose the printed circuit board while power is applied. In no case may components be replaced with power applied. In some instances, dangerous voltages may exist even when power is disconnected. To avoid electrical shock, always disconnect power and discharge circuits before working on the unit.

Exercise care during installation, operation, & maintenance procedures

The equipment described in this manual contains voltages high enough to cause serious injury or death. Only qualified personnel should install, operate, test, and maintain this equipment. Be sure that all personnel safety procedures are carefully followed. Exercise due care when operating or servicing alone.

Do not modify equipment

Do not perform any unauthorized modifications on this instrument. Return of the unit to a Beckwith Electric repair facility is preferred. If authorized modifications are to be attempted, be sure to follow replacement procedures carefully to assure that safety features are maintained.

PRODUCT CAUTIONS

Before attempting any test, calibration, or maintenance procedure, personnel must be completely familiar with the particular circuitry of this unit, and have an adequate understanding of field effect devices. If a component is found to be defective, always follow replacement procedures carefully to that assure safety features are maintained. Always replace components with those of equal or better quality as shown in the Parts List of the Instruction Book.

Avoid static charge

This unit contains MOS circuitry, which can be damaged by improper test or rework procedures. Care should be taken to avoid static charge on work surfaces and service personnel.

Use caution when measuring resistances

Any attempt to measure resistances between points on the printed circuit board, unless otherwise noted in the Instruction Book, is likely to cause damage to the unit.

TABLE OF CONTENTS

M-2286 Adapter Panel Application Guide

Introduction	1
Figure 1 Rear View of M-2286 and Hole Drill Dimensions	2
Figure 2 M-2286 External Connections and Schematic	3
M-0121/M-0169A Auxiliary Current Transformer Units Specifications	5
M-2067B Adapter Panel Application Guide	9
Patent, Warranty and Indemnification	

This Page Left Intentionally Blank

INTRODUCTION

The Beckwith Electric M-2286 Adapter Panel, used in conjunction with the M-2001 Tapchanger Control, uses modern electronic digital design and digital processing circuitry to achieve an overall stability and resolution unattainable with electromechanical and analog design tapchanger controls. CMOS simiconductors are used throughout the design.

Used as a direct replacement for the Westinghouse MS-TM control panel, the M-2286 panel mounts directly into the existing cutout, after the section of the panel between the MS and TM controls has been removed. The M-2286 is 19-3/8" (49.21 cm) high and 11" (27.94 cm) wide.

The M-2286 unit includes voltage waveform sampling and digital processing circuitry that ensures accurate voltage sensing on the input voltage and current. The VOLTMETER TEST TERMINALS allow measurement of the voltage input to verify operation of the M-2286. Refer to the M-2067B Application Guide and the M-2001 Instruction Book for further information.

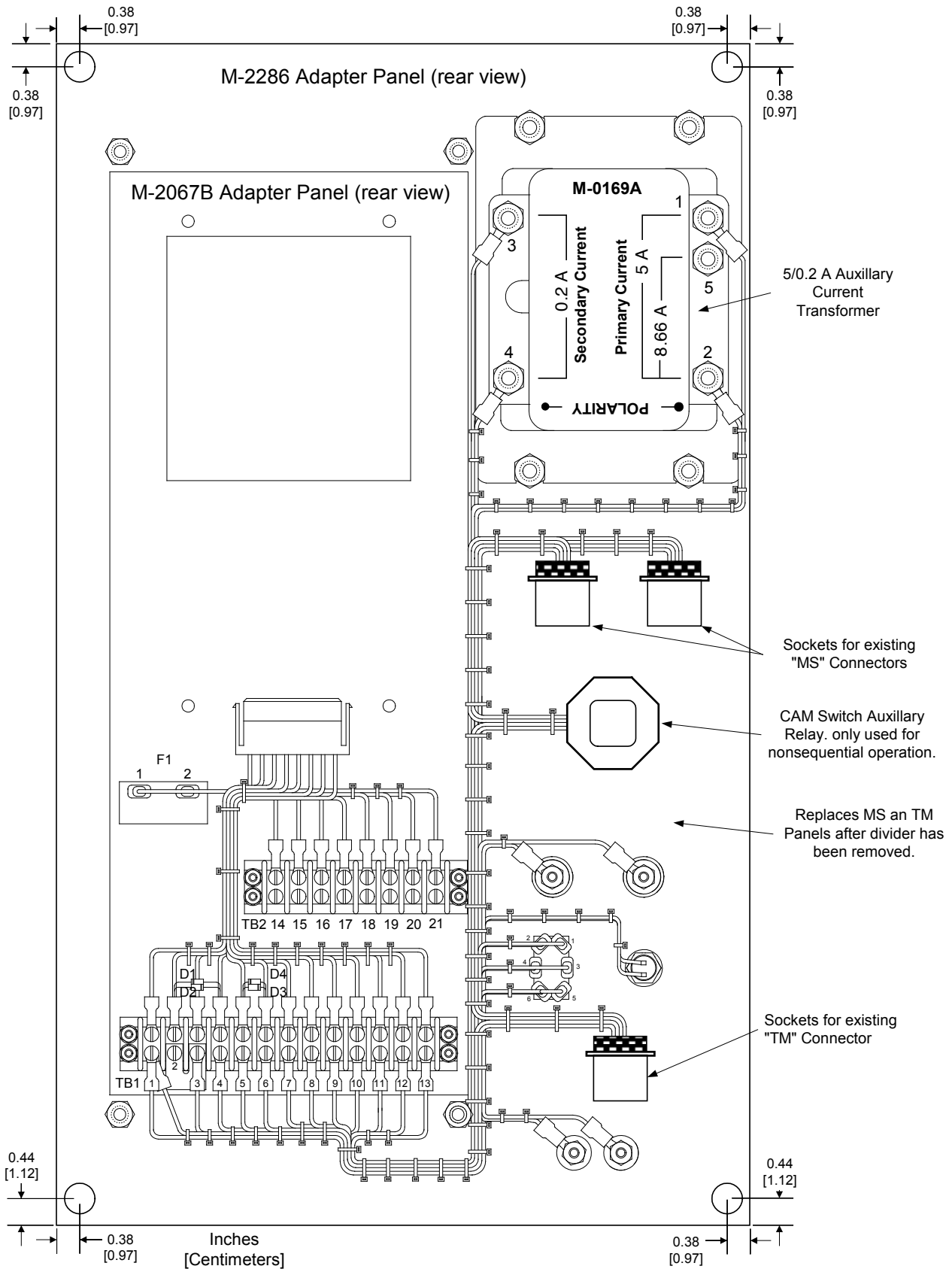
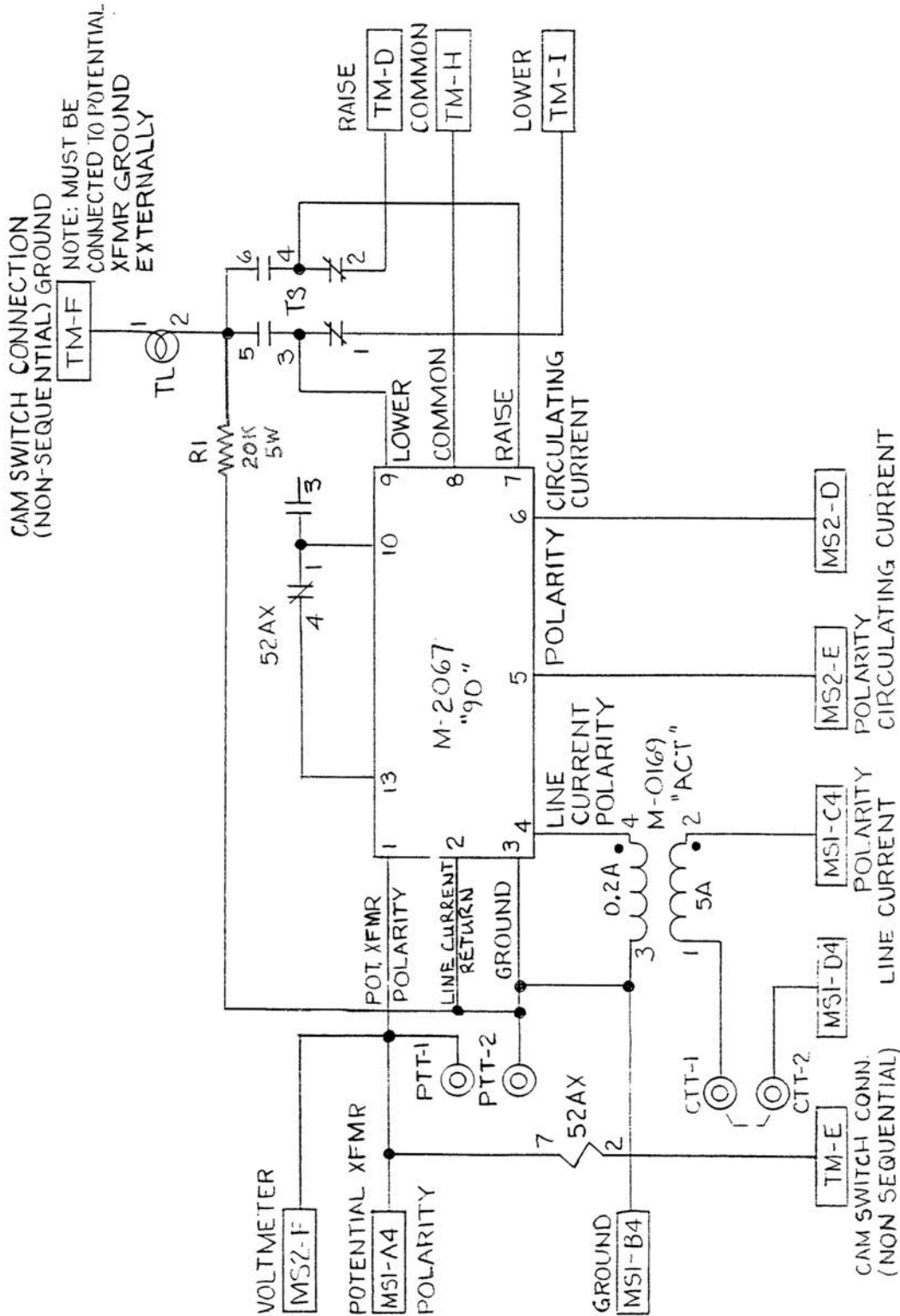

Figure 1 Rear View of M-2286 and Hole Drill Dimensions



BECKWITH-ELECTRIC	CO., INC.	TITLE SCHEMATIC
DWN. CHK. SC	APP. DATE 4/1/94	MS-TM REPLACEMENT PANEL
		DWG. NO. X-2286
		SII. REV. 1/1 B

These drawings and/or specifications are the proprietary property, trade secrets, or patented configurations of Beckwith Electric Co., Inc. and are issued in strict confidence. No reproduction or use shall be made without prior written permission of Beckwith Electric Co., Inc.

Figure 2 M-2286 External Connections and Schematic

This Page Left Intentionally Blank

Auxiliary Current Transformer Units

M-0121

M-0169A

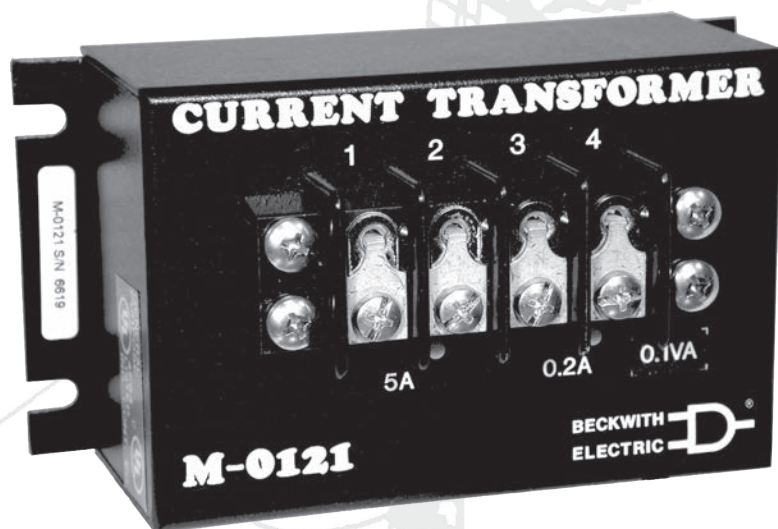

M-0121
For use with Beckwith Electric Tapchanger Controls when there is no additional burden present.

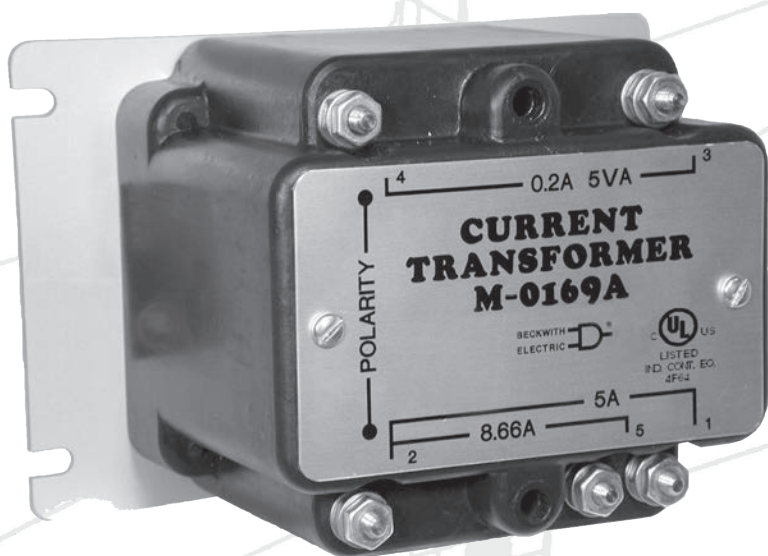

M-0169A
For use in higher burden current circuits, such as those found in paralleling schemes. Output is protected against overvoltage.

M-0120/M-0169 Specification

Line Current, used for Line Drop Compensation, is provided by an Auxiliary Current Transformer. The current transformer drops the line current to a 0.2 A full scale rating. The M 0121 or M 0169A can be used for CTs with a 5 A secondary. The M 0169A can be used for CTs with either a 5 A or 8.66 A secondary.

Input

M-0121: Nominal 5 A current transformer circuit.

M-0169A: Nominal 5 A or 8.66 A current transformer circuit.

Output

Nominal 0.2 A \pm 5%, linear to 0.4 A.

Output Rating

M-0121: (into M-0067 terminals 3 to 4 or 5 to 6) 0.1 VA, 0.2 A current.

M-0169A: 5 VA, 0.2 A current.

Input Current Withstand		Maximum Time
8.66 A (M-0169A Only)	5 A (Either Unit)	
216 A	125 A	2 sec.
173 A	100 A	3 sec.
142 A	82 A	4 sec.
125 A	72 A	5 sec.
17 A	10 A	Continuous

HI POT: 1500 Vac rms. Primary to secondary and either to case.

Mounting Dimensions

M-0121: 5" x 2-1/8" (12.7 cm x 5.1 cm), 4 holes, 7/32" (0.6 cm) diameter.

M-0169A: 5-5/8" x 3" (14.3 cm x 7.6 cm), 4 holes, 7/32" (0.6 cm) diameter.

Compliance

cULus-Listed per 508 – NMTR.E155037 Industrial Control Equipment
– NMTR7.E155037 Industrial Control Equipment Certified for Canada
CAN/USA C22.2 No. 14-M91

Terminal Block Connections/Torque Requirements

M-0121: The wire should be No. 16–14 AWG inserted in an AMP #324915 (or equivalent) connector, and both screws tightened to 16 inch-pounds (1.8 N m) torque.

M-0169A: The wire should be No. 12 AWG inserted in an AMP #35109 (or equivalent) connector, and both screws tightened to 20 inch-pounds (2.26 N m) torque.

Approximate Weight

M-0121: 1 lb (0.45 kg)

M-0169A: 2.5 lbs (1.1 kg)

Approximate Shipping Weight

M-0121: 2 lbs (0.9 kg)

M-0169A: 3.5 lbs (1.6 kg)

Warranty

M-0121 and M-0169A units are covered by a five year warranty from date of purchase.

Specification is subject to change without notice.

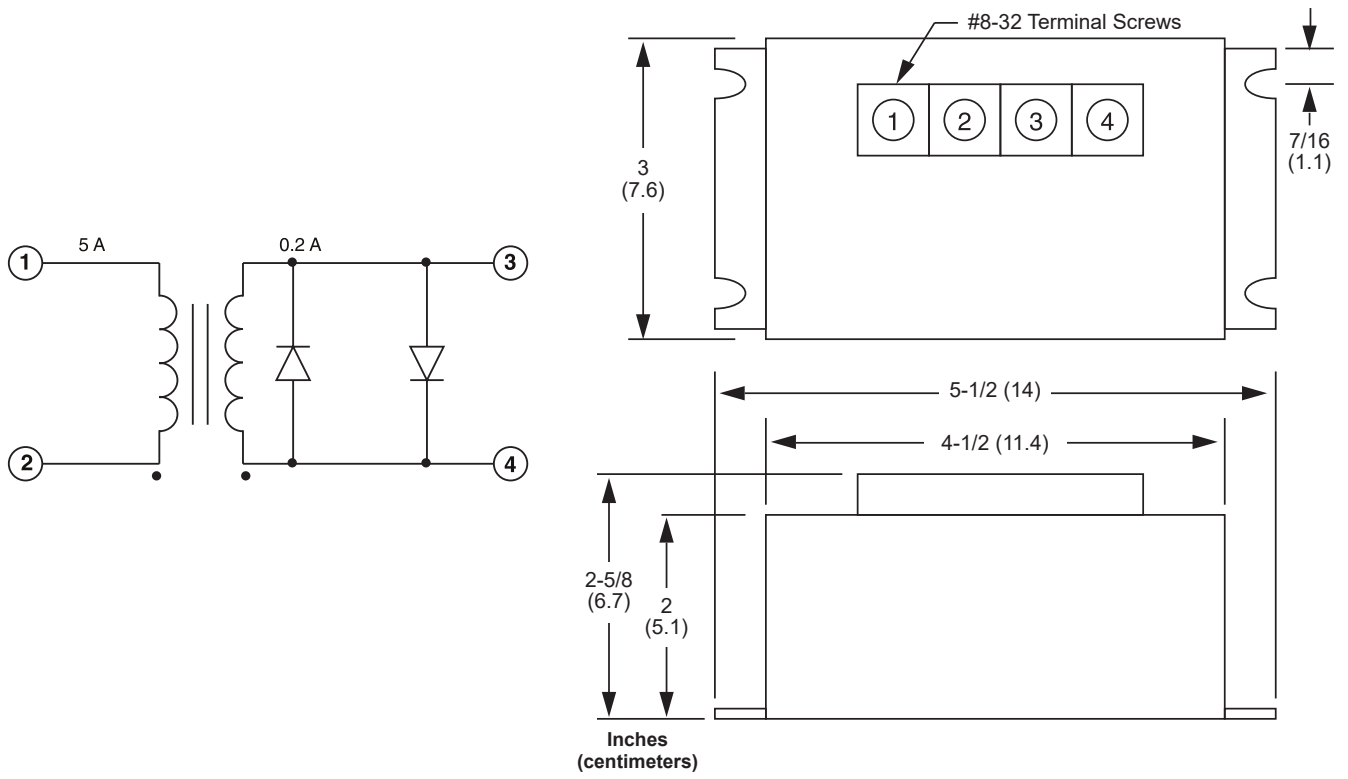

Figure 1 M-0121 Outline Dimensions

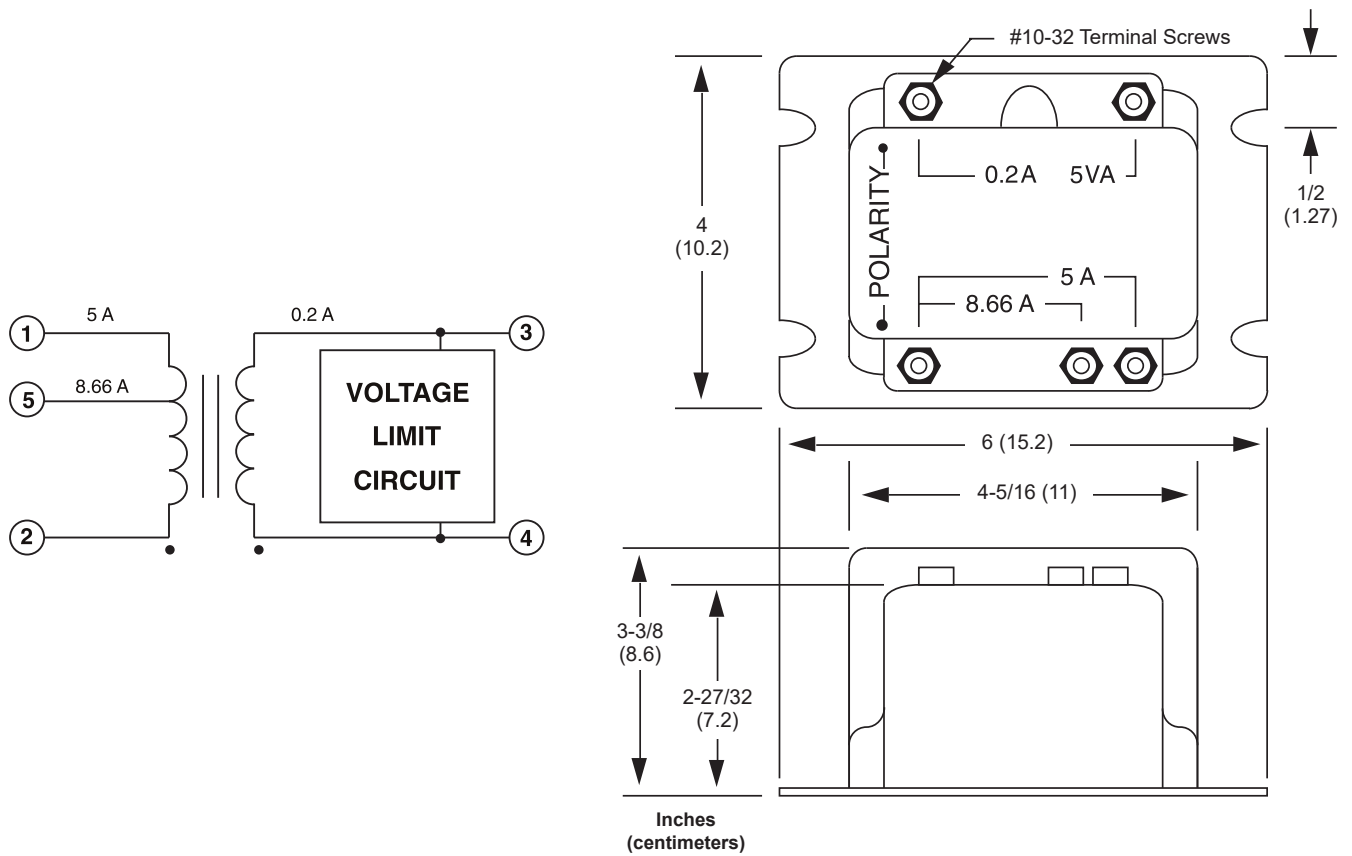

Figure 2 M-0169A Outline Dimensions



BECKWITH ELECTRIC

6190 118th Avenue North • Largo, Florida 33773-3724 U.S.A.

PHONE (727) 544-2326

beckwithelectricshupport@hubbell.com

www.beckwithelectric.com

ISO 9001:2015



A proud member of the Hubbell family.



Application Guide

**M-2067B
Adapter Panel**

**BECKWITH
ELECTRIC** 



A proud member of the Hubbell family.

TRADEMARKS

All brand or product names referenced in this document may be trademarks or registered trademarks of their respective holders.

The content of this Instruction Book is provided for informational use only and is subject to change without notice. Beckwith Electric has approved only the English version of this document.

Adapter Panel M-2067B

Adapts M-2001 Series Digital Tapchanger Control to Replace Westinghouse SVC and SVR Controls and Beckwith Electric M-0067 Tapchanger Controls, or as a General Purpose LTC Transformer Control



- **Connects easily to the M-2001 Series Digital Tapchanger Control using four mounting screws and 24-pin connector**
- **Provides mounting adaptable to several different configurations**
- **Provides built-in CT shorting protection when the M-2001 Series Tapchanger Control is removed**

M-2067B Adapter Panel – Specification

The M-2067B is an adapter panel which, when combined with the M-2001 Series Digital Tapchanger Control, provides convenient direct replacement for Westinghouse SVC and SVR controls and Beckwith Electric M-0067 series controls. The M-2067B can also be used, with the M-2001 Series Tapchanger Control, as a general purpose LTC transformer control. The M-2067B permits changing of the M-2001 control without adapter panel removal or rewiring.

Interface

External connections are made to two terminal blocks located on the rear of the adapter panel. The second terminal block provides auxiliary functions, including self-test alarm, user-programmable alarm, manual raise/lower, operations counter and ΔVAr 2 disable.

Testing Specifications

High Voltage: All input and output terminals will withstand 1500 Vac rms to chassis or instrument ground for one minute with a leakage current not to exceed 25 mA, for all terminals to ground. Input and output circuits are electrically isolated from each other, from other circuits and from ground.

Surge Withstand Capability: All input and output circuits are protected against system transients. Units pass all requirements of ANSI/IEEE C.37.90.1-1989 defining surge withstand capability.

Radiated Electromagnetic Withstand Capability: All units are protected against electromagnetic radiated interference from portable communications transceivers.

Control Accuracy Specification: All units comply with ANSI/IEEE C57.15-1986 defining control accuracy of operation.

Environmental

Temperature Range: Functionality is maintained from -40° to $+85^{\circ}$ C.

Humidity: Functionality is maintained under 95% relative humidity (non-condensing).

Fungus Resistance: A conformal printed circuit board coating inhibits fungus growth.

Physical

Size with M-2001 Series Tapchanger Control: Overall dimensions are 16-1/2" high x 6-3/8" wide x 3-3/8" deep (41.9 cm x 16.2 cm x 8.6 cm); requires a panel cutout of 15-1/8" x 5-7/8" (38.4 cm x 14.9 cm)

Approximate Weight: 2 lbs (0.91 kg)

Approximate Shipping Weight: 5 lbs (2.27 kg)

Approximate Weight with M-2001 Series Tapchanger Control: 5 lbs, 11 oz (2.58 kg)

Approximate Shipping Weight with M-2001 Series Tapchanger Control: 10 lbs, 11 oz. (4.85 kg)

Warranty

The M-2067B Adapter Panel is covered by a five year warranty from date of shipment.

Specification subject to change without notice.

BECKWITH ELECTRIC

6190 118th Avenue North • Largo, Florida 33773-3724 U.S.A.

PHONE (727) 544-2326

beckwithelectricssupport@hubbell.com

www.beckwithelectric.com

ISO 9001:2015



A proud member of the Hubbell family.

TABLE OF CONTENTS

M-2067B Adapter Panel Application Guide

1.0	Introduction	1
1.1	Description.....	1
	Standard Features.....	1
2.0	Application.....	1
	Typical Connections	1
	External Connections	1
	Lightning Protection.....	2
	Non-Sequential Operation	2
	Operations Counter Input	2
	Multi-Step Voltage Reduction	3
	Figure 1 M-2001 and M-2067B Typical Connections.....	3
	Figure 2 External Connections.....	4
	Table 1 Multi-Step Voltage Reduction External Connections.....	5
	Paralleling.....	5
	Operations Counter Input	5
	M-2001 Tapchanger Control Software Settings.....	5
	Figure 3 M-2067B Wiring Harness and External Connections	6
	Use of the M-0329B LTC Backup Control with the Tapchanger Control.....	7
	M-0329B LTC Backup Control Settings.....	7
	Figure 4 Tapchanger Control and LTC Backup Control Interconnections.....	7
3.0	Installation	8
	Installing the M-2067B/M-2001.....	8
	Figure 5 M-2001 Harness Connector.....	8
	Figure 6 M-2001 V-Notch Orientation	8
	Installation of the M-2067B Adapter Panel	8
	UL-Approved Terminal Block Connections	8
	Figure 7 M-2067B Wire Terminations for External Connections as Required for UL Listing.....	9
	Figure 8 Outline Dimensions.....	9
	Figure 9 M-2067B Panel Cutout Dimensions.....	10
4.0	Bench Test (M-2001 Connected to M-2067B).....	11
	Test Equipment.....	11
	Setup	11
	Table 2 Initial Settings	11
	Procedure	11
	Resistance.....	11
	Reactance	12
	Paralleling.....	12
	Counter.....	12
	Block Raise/Block Lower/Dead Band	12
	Figure 10 M-2067B Test Procedure External Connection.....	13

4.1	M-2001 Checkout Procedure	14
	Basic Operational Test.....	14
4.2	In-Service Test	14
4.3	M-2067B Checkout Procedure	14
	POWER.....	14
	Figure 11 Setup for Current Checkout Procedure	15
5.0	Converting Westinghouse CVR/CVC Tapchanger Control to M-2067B/M-2001C Tapchanger Control.....	16
	Introduction.....	16
	Instructions	16
	Table 3 Westinghouse CVR/CVC and M-2067B Terminal Block Designations.....	17
5.1	Check-out Instructions for Westinghouse CVR/CVC Conversion to M-2067B/M-2001C Tapchanger Control.....	19
	Table 4 Check-out Settings	19
	Figure 12 Westinghouse CVR-1 Replacement	20
	Figure 13 Westinghouse CVR-1 Replacement With M-2067B	21

1.0 Introduction

The Beckwith Electric M-2067B Adapter Panel, used in conjunction with the M-2001 Tapchanger Control, uses modern electronic digital design and digital processing circuitry to achieve an overall stability and resolution unattainable with electromechanical and analog design tapchanger controls. CMOS semiconductors are used throughout the design.

1.1 Description

Standard Features

The M-2067B Adapter Panel, with the M-2001 Tapchanger Control, provides a solid-state voltage control relay intended for applications involving the control of tapchanging transformers and regulators. The combination of the Tapchanger Control and Adapter Panel includes the following features:

- Voltage waveform sampling and digital processing circuitry ensure accurate rms voltage sensing in the presence of distortion on the input voltage and current.
- Control accuracy is $\pm 0.3\%$ when tested in accordance with the ANSI/IEEE C57.15.9-1999 standard over a temperature range of -30°C to $+65^{\circ}\text{C}$. The control accuracy is $\pm 0.5\%$ when tested over the full operational temperature range of -40°C to $+85^{\circ}\text{C}$.
- Input and output circuits are protected against system transients. Units pass all requirements of ANSI/IEEE C37.90.1-1989, which defines surge withstand capability. All input and output terminals will withstand 1500 Vac rms to chassis or instrument ground for one minute with a leakage current not to exceed 25 mA, for all terminals to ground. Input and output circuits are electrically isolated from each other, from other circuits and from ground.
- The Adapter Panel includes a replaceable Voltage Sensing Fuse. A spare fuse is provided in the fuse holder.

2.0 Application

Typical Connections

In general, the tapchanger motor must be operated from a different transformer than the VT used to measure regulated voltage. If this is not done, hunting at the upper band edge may result. As soon as the motor starts and before it is sealed in, the motor current can drop the voltage within the band and reset the control. Some motor seal-in schemes are fast enough to prevent this, but others are not.

A typical connection for an M-2067B is shown in [Figure 2](#) and [Figure 3](#). Connections are simplified and may not show all functions required in a typical load tapchanging transformer control scheme; for example, limit switches, etc.

External Connections

Power and voltage sensing are obtained either from a common source or from independent sources having a nominal 120 Vac output. Normally, this is line-to-neutral voltage, although line-to-line voltage can also be used if recognition is made of any phase shift between the voltage and current signals when using line drop compensation.

M-2067B Application Guide

Load current must be reduced by an appropriate auxiliary current transformer to 0.2 A "full scale" before connecting to the M-2067B current inputs. The Beckwith Electric M-0121 (5.0 A to 0.2 A) or M-0169A (5.0 A or 8.66 A to 0.2 A) Auxiliary Current Transformer can be used for this purpose. The M-0121 can be used with Beckwith Electric Tapchanger Controls when the only burden present is the Line Drop Compensator circuit of the voltage regulating relay. The M-0169A is used in higher burden circuits, such as are found in paralleling schemes. Outputs of the auxiliary CTs are protected against overvoltage. If the Load Current Input must be isolated, then remove the jumper between TB1-2 and TB1-3. For further information, obtain Beckwith Electric Application Note #17, "Basic Considerations for the Application of LTC Transformers and Associated Controls."

The external connections for the M-2067B are made to terminal blocks TB1 and TB2 on the printed circuit board at the base of the adapter panel. The wiring harness and external connections for the M-2067B are shown in [Figure 2](#) and [Figure 3](#).

Lightning Protection

▲ CAUTION: For proper protection against system surges, chassis ground must be connected to earth ground.

It has been determined that transient voltages in excess of 1500 Vac rms can exist on the "ground" lead normally tied to TB1-3 on the printed circuit board. In the Tapchanger Controls, these voltages are suppressed by varistors which still permit the unit to pass a 1500 Vac Hi Pot test for one minute with a leakage current of approximately 15 mA, all terminals to ground.

Multiple VT grounds far apart must be avoided since a varying difference in ground voltage could add or subtract from the effective voltage and cause variation in the Tapchanger Control's bandcenter voltage setpoint.

Non-Sequential Operation

The operation of the M-2067B can be interrupted during tapchanger operation by momentarily applying the "wetting" voltage of terminal TB1-13 to TB1-10 (timer reset for non-sequential operation input) through an external contact. This causes the output to de-energize and reinitialize the time delay circuit when the reset signal is removed. This function can be used to cause the LTC transformer, if so equipped, to wait for the unit to time out between tapchanges.

▲ CAUTION: Voltage applied through dry contacts to actuate non-sequential input *must* be nominal +12 Vdc obtained from pin TB1-13 of the M-2067B adapter panel. If an M-0067B analog-version tapchanger control had previously been installed, the wiring harness must be reconfigured since the M-2067B is not a direct pin-to-pin replacement for the analog M-0067B.

Operations Counter Input

▲ CAUTION: Do not apply any voltage to this terminal.

An operations count is registered by momentarily grounding TB2-20 through an external dry contact from the load tapchanger. The input is level-sensitive. Make sure that any "wetting" voltages are removed from the counter contacts before installing the M-2067B Adapter Panel/M-2001 Tapchanger Control.

Multi-Step Voltage Reduction

On the M-2067B, TB1-11 and TB1-12 on the printed circuit board are used together to provide up to three levels of voltage reduction. The external connections to achieve these steps are shown in [Figure 1](#) and [Figure 2](#) and [Table 1](#). Voltage reduction amounts are set within the M-2001 Tapchanger Control software.

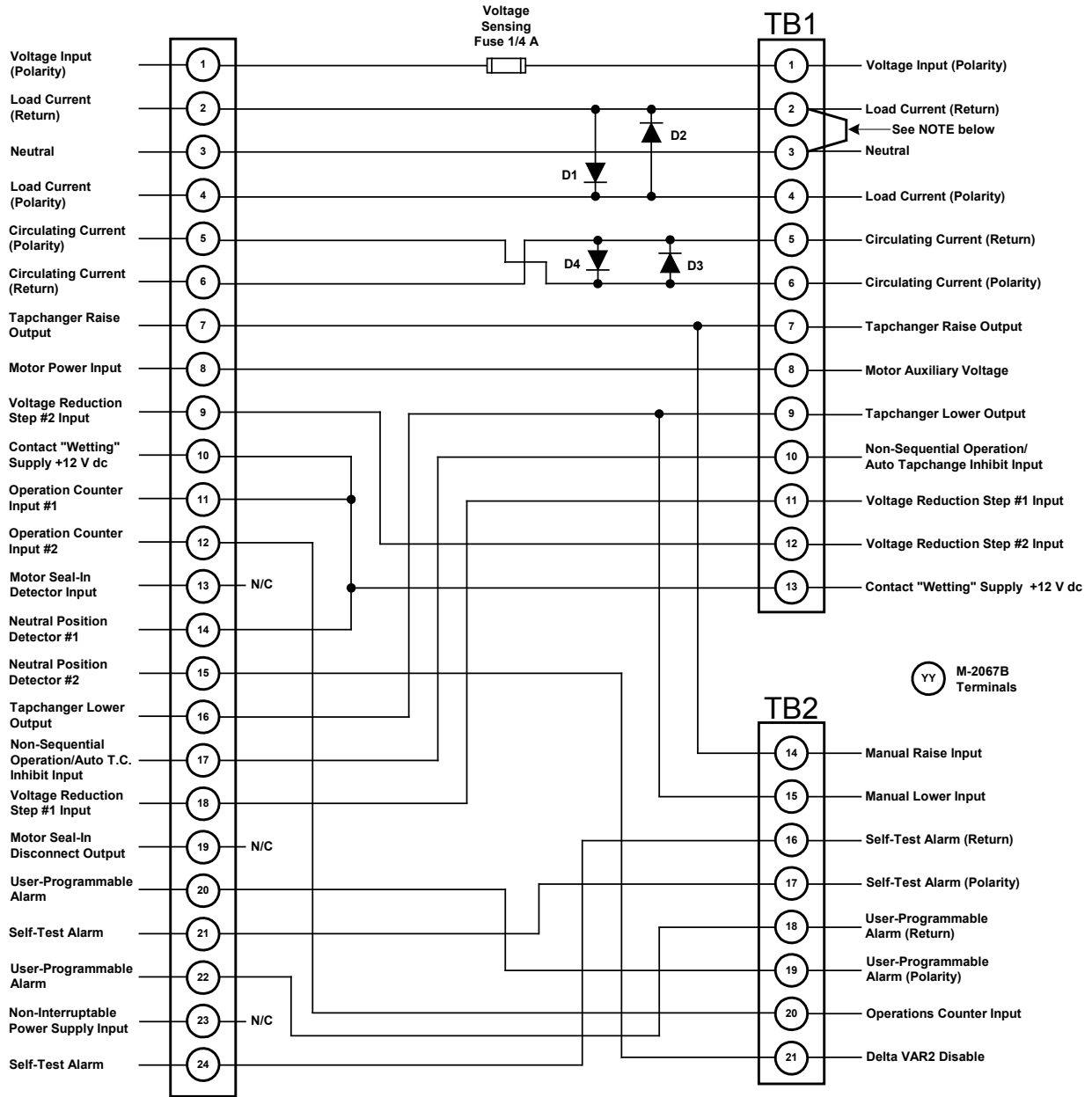

WARNING: In no case should the line current circuit be interrupted with the regulator or transformer energized. Do not remove auxiliary current transformers without shorting the current inputs. Death or severe electrical shock can occur.

NOTE: To isolate the load current, remove the jumper from between TB1-2 to TB1-3.

Figure 1 M-2001 and M-2067B Typical Connections

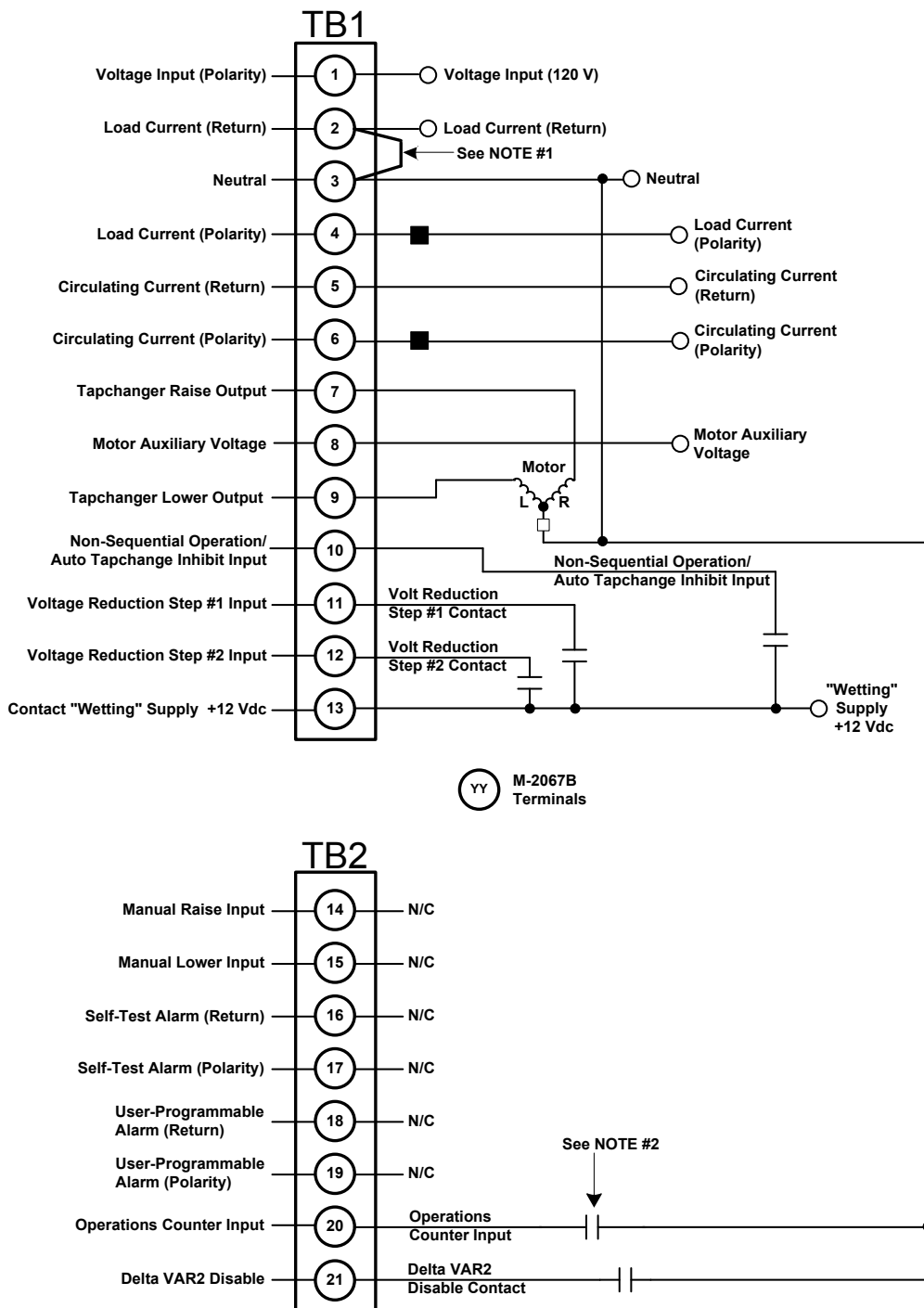

WARNING: Open CT secondary will result in high voltage at CT terminals. Death, severe injury or damage to equipment can occur. Do not operate with CT secondary open. Short circuit or apply burden at CT secondary during operation.

- NOTES:**
1. To isolate the load current, remove the jumper from between TB1-2 to TB1-3.
 2. For counter operation, connect TB2-20 to Neutral TB1-3 through an external dry contact.

Figure 2 External Connections

Voltage Reduction Setpoint: Multiplier Range	Apply "Wetting Voltage" from TB1-13 to Terminal #
Voltage Reduction Setpoint #1:0 to 10%	TB1-11
Voltage Reduction Setpoint #2:0 to 10%	TB1-12
Voltage Reduction Setpoint #3:0 to 10%	TB1-11 and TB1-12

Table 1 Multi-Step Voltage Reduction External Connections

▲ CAUTION: Voltage applied through dry contacts to actuate Voltage Reduction Steps 1, 2, and 3 *must* be nominal +12 Vdc obtained from pin TB1-13 of the M-2067B adapter panel. If an M-0067B analog-version tapchanger control had previously been installed, the wiring harness must be reconfigured since the M-2067B is not a direct pin-to-pin replacement for the analog M-0067B.

Paralleling

See M-2001C Instruction Book, Section 4.9, Parallel Operation.

Operations Counter Input

▲ CAUTION: Do not apply either +12 Vdc or 120 Vac to this terminal.

An operations count is registered by momentarily grounding TB1-13 through an external dry contact from the load tapchanger. The input is level-sensitive. Make sure that any "wetting" voltages are removed from the counter contacts before installing the M-2067B Adapter Panel/M-2001 Tapchanger Control.

M-2001 Tapchanger Control Software Settings

Adjust the BANDCENTER setting to the nominal voltage desired. Adjust the BANDWIDTH setting to the desired voltage band, centered on the Bandcenter setpoint, that the voltage must exceed before timer and subsequent tapchanger operation occurs. Adjust the TIME DELAY setpoint to a sufficient amount to eliminate excessive tapchanger operations. The LINE DROP COMPENSATOR should be set for the line impedance from the transformer to the load center. For further information, obtain Beckwith Electric Application Note #17, "Basic Considerations for the Application of LTC Transformers and Associated Controls."

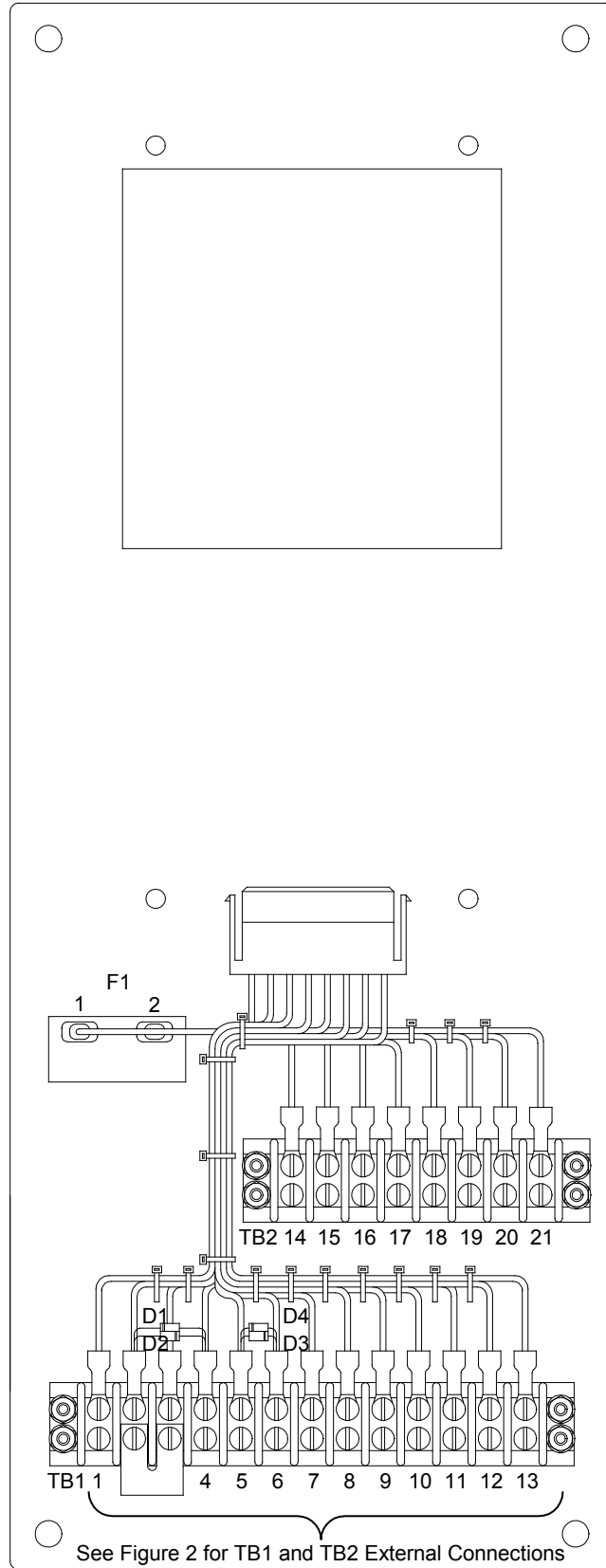

Figure 3 M-2067B Wiring Harness and External Connections

Use of the M-0329B LTC Backup Control with the Tapchanger Control

The M-0329B is a single-phase, solid-state backup control that prevents a defective tapchanger control from running the voltage outside the upper and lower voltage limits. The Block Raise and Block Lower voltage levels are set by accurately calibrated dials.

The M-0329B LTC Backup Control is connected as a two terminal device to the voltage transformer. [Figure 4](#) shows the typical interconnection of the two devices with motor auxiliary relays.

The M-0329B Instruction Book is available on request and gives added details. Please refer to the M-0329B Instruction Book for complete ordering information.

M-0329B LTC Backup Control Settings

The BANDCENTER and BANDWIDTH dials on the M-0329B LTC Backup Control should be set so that the Block Lower limit is a small amount (approximately 2 V) below the lower band limit of the Tapchanger Control, and the Block Raise limit is a similar amount above the upper limit if line drop compensation is not used.

If line drop compensation is used, the M-0329B Block Raise limit should be set at the maximum voltage desired at the transformer secondary under full load.

The M-0329B LTC Backup Control also includes a deadband or runback function that regulates the maximum voltage from the transformer. This "Lower" function operates slightly above the Block Raise limit and is connected to force the tapchanger to lower the voltage if the upper limit is exceeded.

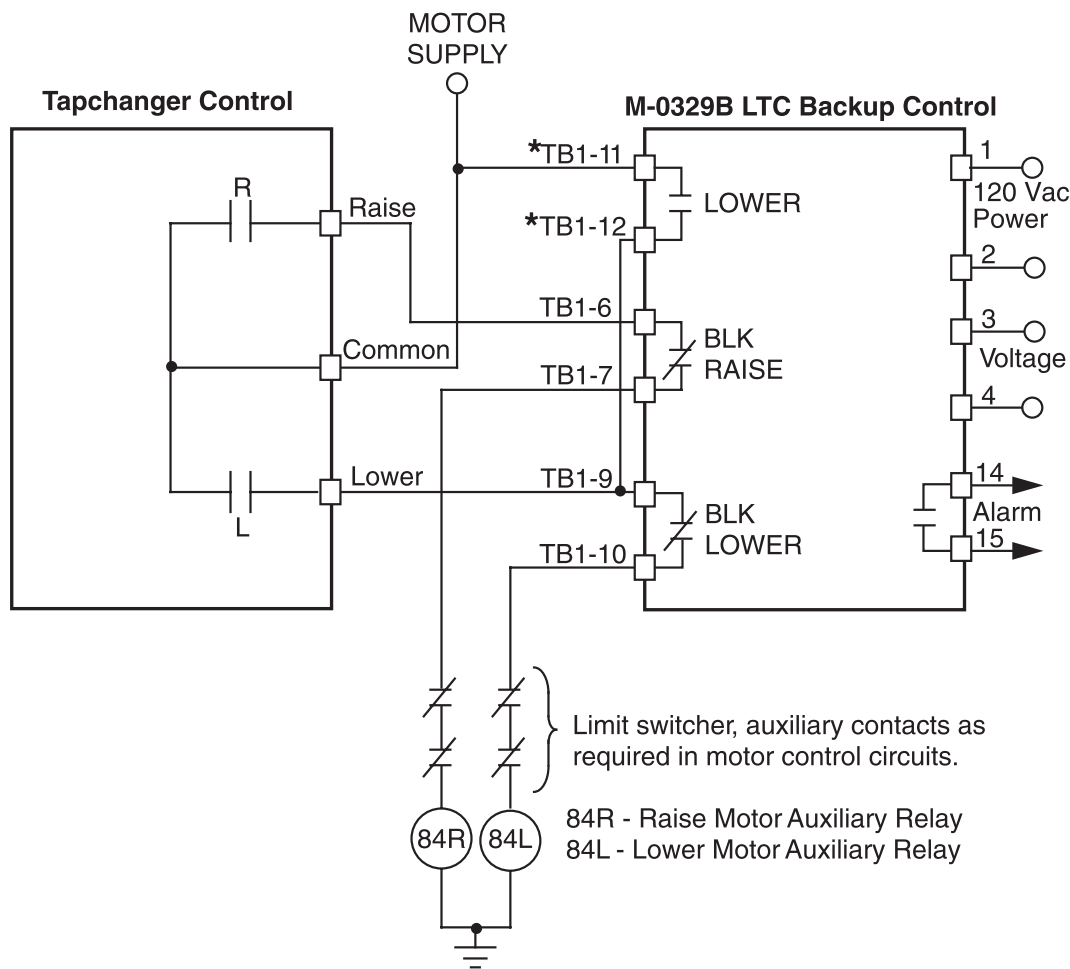

NOTE: * If first customer protection is not required, delete these connections.

Figure 4 Tapchanger Control and LTC Backup Control Interconnections

3.0 Installation

The M-2067B is a general purpose adapter panel that is designed for mounting in a 5-7/8" x 15-1/8" panel cutout. Remove the old control from the cabinet. Refer to [Figure 8](#) for outline dimensions; refer to [Figure 9](#) for panel cutout dimensions of the M-2067B.

Installing the M-2067B/M-2001

1. Mount the M-2001 to the M-2067B Adapter panel by using the hardware provided in the cloth bag. Use the lock washers supplied between the screws and the top of the front panel.

■ **NOTE:** The blue connector is keyed by a "V" notch in the middle to prevent incorrect mating ([Figure 5](#)). Check location of the key before plugging connector into the M-2001.

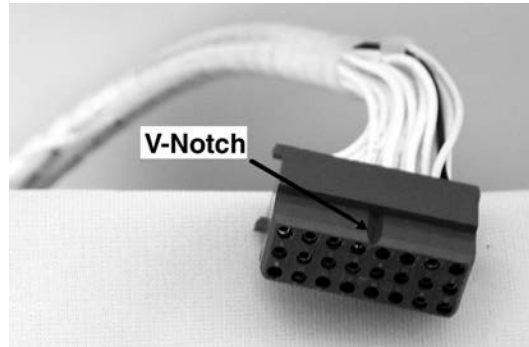

Figure 5 M-2001 Harness Connector

2. Plug the blue connector of the M-2067B harness into the bottom of the M-2001.

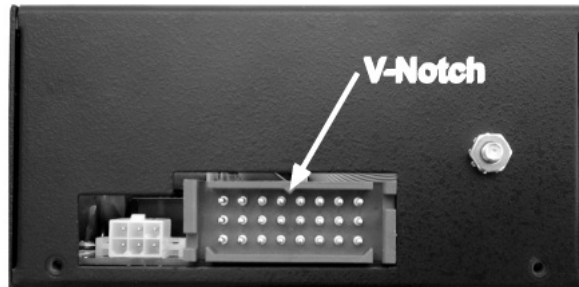

Figure 6 M-2001 V-Notch Orientation

If desired, bench testing may be performed as described in Section 4.0, Bench Test.

Installation of the M-2067B Adapter Panel

Mount the M-2067B Adapter Panel (with the M-2001 Tapchanger Control) in the control cabinet. External connections are made to the terminal block on the rear of the adapter panel. [Figure 1](#), [Figure 2](#) and [Figure 3](#) show the M-2067B external connections.

UL-Approved Terminal Block Connections

The M-2067B Adapter Panel is listed to UL Standards for Safety by Underwriters Laboratories Inc. (UL). To fulfill the UL requirements, terminal block connections must be made as illustrated in the [Figure 7](#):

The wire should be No. 16-14 AWG inserted in an AMP #51864 (or equivalent) connector, and both screws tightened to 8 inch-pounds torque.

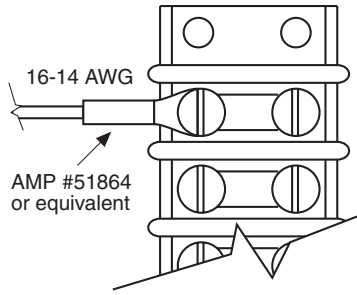

Recommended Wire Terminations

Tighten to 8 inch-pounds

Figure 7 M-2067B Wire Terminations for External Connections as Required for UL Listing

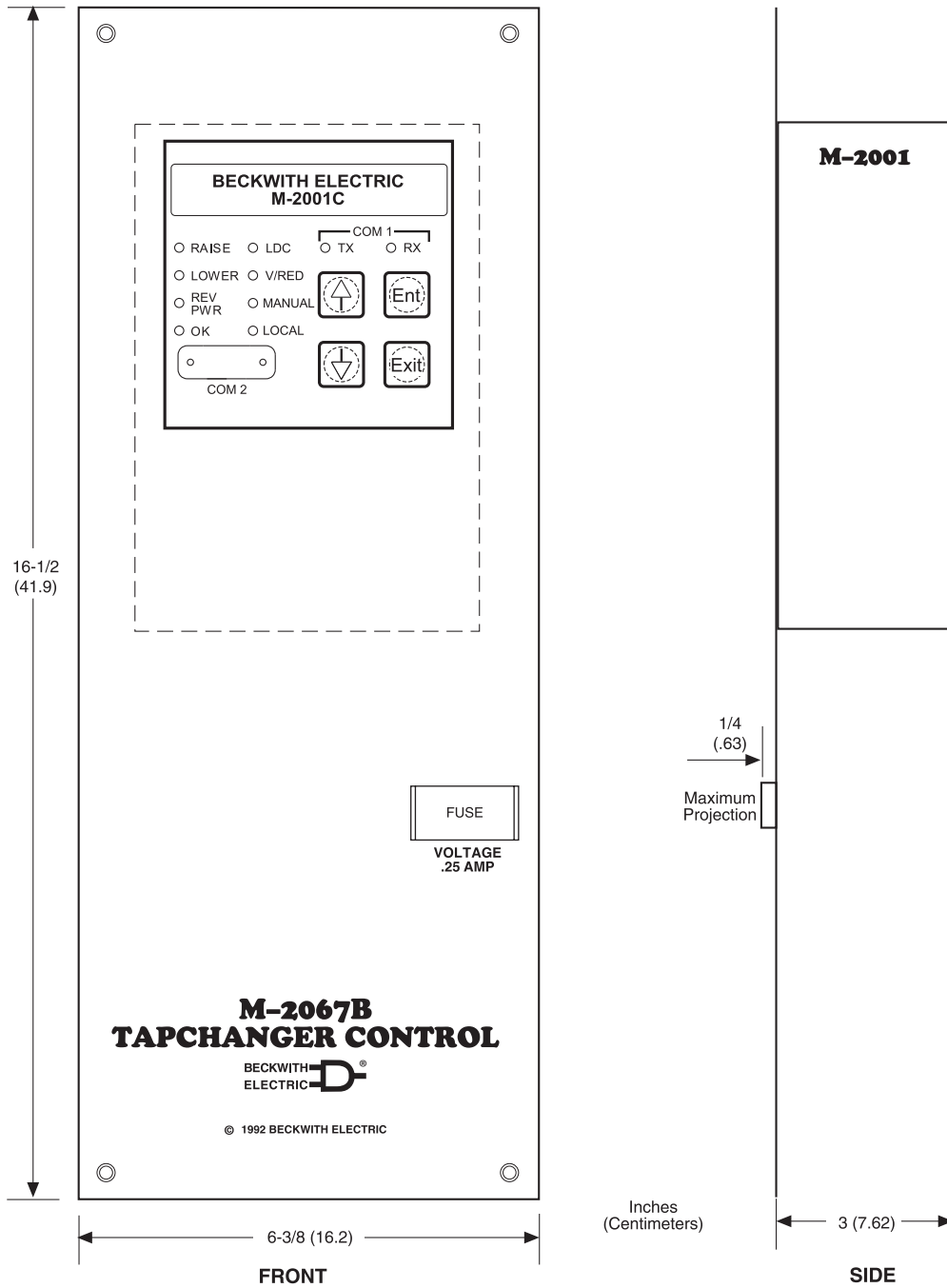

Figure 8 Outline Dimensions

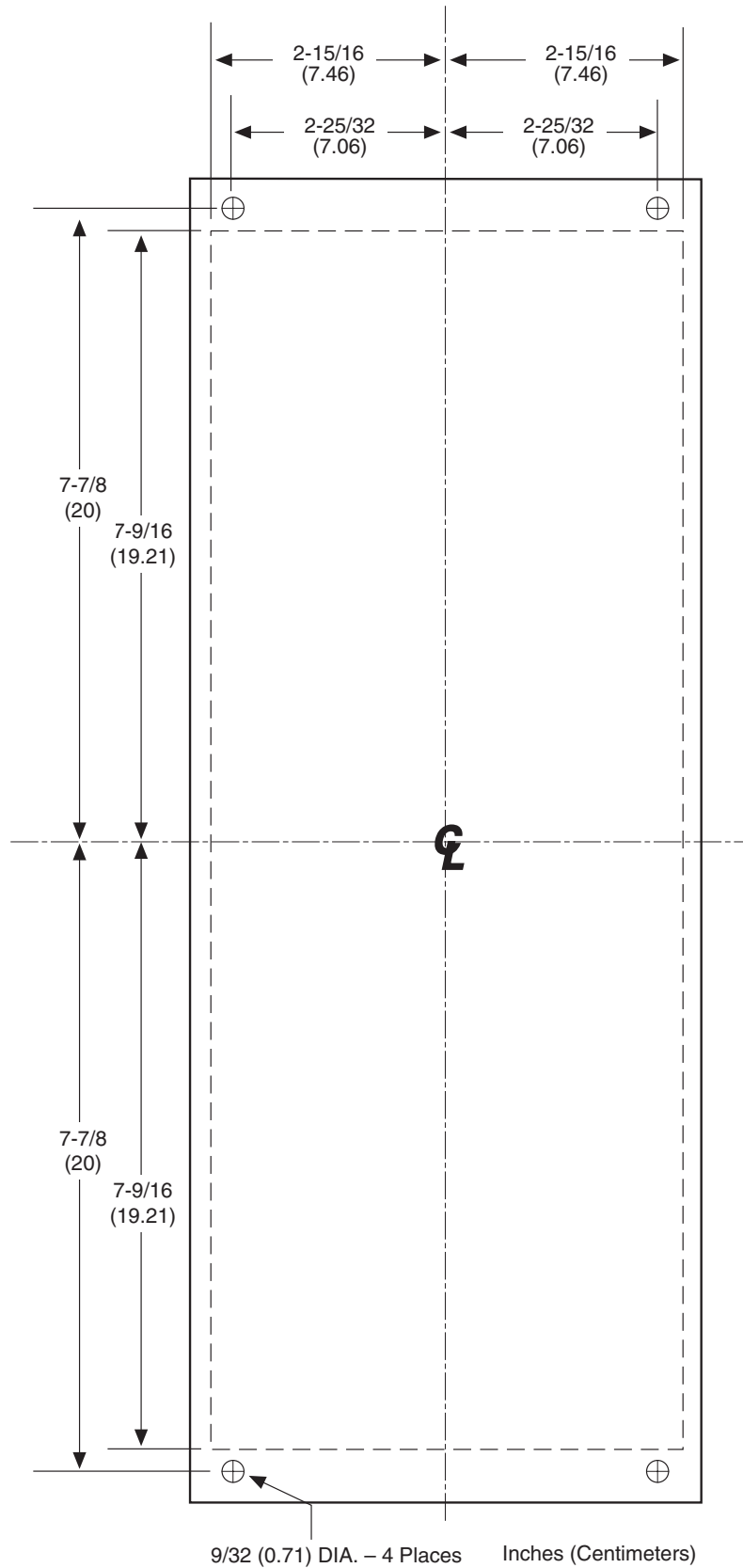

Figure 9 M-2067B Panel Cutout Dimensions

4.0 Bench Test (M-2001 Connected to M-2067B)

■ **NOTE:** This test assumes that the M-2001 Tapchanger Control is connected to the M-2067B Adapter Panel.

Test Equipment

- 0–200 mA current supply with phase angle settings of 0° to +90°
- 90–145 Vac voltage source at 60 Hz
- High impedance true RMS voltmeter with accuracy on ac of at least $\pm 0.2\%$ of reading
- Accurate Stop watch

Setup

1. Make the electrical connections as shown in [Figure 10](#).

■ **NOTE:** Refer to the M-2001C Instruction Book Appendix A, Figures A-1 through A-13 for the locations of screens within the software.

■ **NOTE:** There is a one second delay between the out-of-band condition and panel LED indication.

2. Enter initial M-2001 settings:

Initial Settings	
Bandcenter	120.0 V
Bandwidth	2.0 V
LDC Resistance	0.0 V
LDC Reactance	0.0 V
Paralleling	Circulating Current Method
Block Raise	135.0 V
Block Lower	105.0 V
Deadband	2.0 V
Timer	5.0 Seconds

Table 2 Initial Settings

Procedure

1. Apply 120.0 Vac from power source.
2. The display of the M-2001 will automatically advance to the **Local Voltage** screen.
3. Increase voltage to 121.2. The **LOWER** LED should illuminate.
4. Decrease voltage to 118.8. The **RAISE** LED should illuminate.
5. Set input voltage to 120.0 Vac. Wait for **RAISE** and **LOWER** LEDs to extinguish.
6. Increase voltage to 122.0 Vac, then start timing when voltage passes 121.0 V.
7. Stop timing when the lamp connected to the **LOWER** output illuminates (should be approximately 5 seconds).

Resistance

1. Apply 100.0 mA in-phase current to TB1-4 (load current-polarity) and TB1-2 (load current-return) of the adapter panel. (Set S1 to LDC and S2 to IL.)
2. Set LDC Resistance to 24.0 V. The **RAISE** LED should illuminate.
3. Increase input voltage to 132.0 Vac. The **RAISE** and **LOWER** LEDs should be extinguished.
4. Set LDC Resistance to -24.0 V. The **LOWER** LED should illuminate.
5. Decrease input voltage to 108.0 Vac. Both **RAISE** and **LOWER** LEDs should extinguish.
6. Set LDC Resistance to 0.0 V.

Reactance

1. Apply 100.0 mA 90° leading current to TB1-4 (load current-polarity) and TB1-2 (load current-return) of the adapter panel.
2. Set S₁ to LDC and S₂ to I_L.
3. Set LDC Reactance to 24.0 V. The **LOWER** LED should illuminate.
4. Decrease input voltage to 108.0 Vac. The **RAISE** and **LOWER** LEDs should be extinguished.
5. Set LDC Reactance to -24.0 V. The **RAISE** LED should illuminate.
6. Increase input voltage to 132.0 Vac. Both **RAISE** and **LOWER** LEDs should be extinguished.
7. Set LDC Reactance to 0.0 V.

Paralleling

1. Apply 100.0 mA 90° leading current to TB1-6 (circulating current-polarity) and TB1-5 (circulating current-return) of the adapter panel.
2. Set S₁ to CIRC and S₂ to I_P
3. The **LOWER** LED should illuminate.
4. Decrease voltage to 108.0 Vac. Both **RAISE** and **LOWER** LEDs should be extinguished.
5. Set S₁ to **OFF**.

Counter

1. Set the M-2001 Tapchanger Control to display the Operations Count screen.
2. Verify the counter operation by depressing the switch wired to TB1-20 (operations counter input).
3. The tap position should change.

Block Raise/Block Lower/Dead Band

1. Set Block Raise to 126.0 V.
2. Set Block Lower to 114.0 V.
3. Set the M-2001 Tapchanger Control to display the **Bias Voltage** screen.
4. Press **Enter**.
5. Increase voltage to 126.5 V. **BR** should be displayed on the screen.
6. Increase voltage to 128.5 V. **BR** extinguishes and **FL** is displayed on the screen.
7. Decrease voltage to 113.5 V. **BL** is displayed on the screen.

—Bench Test Complete—

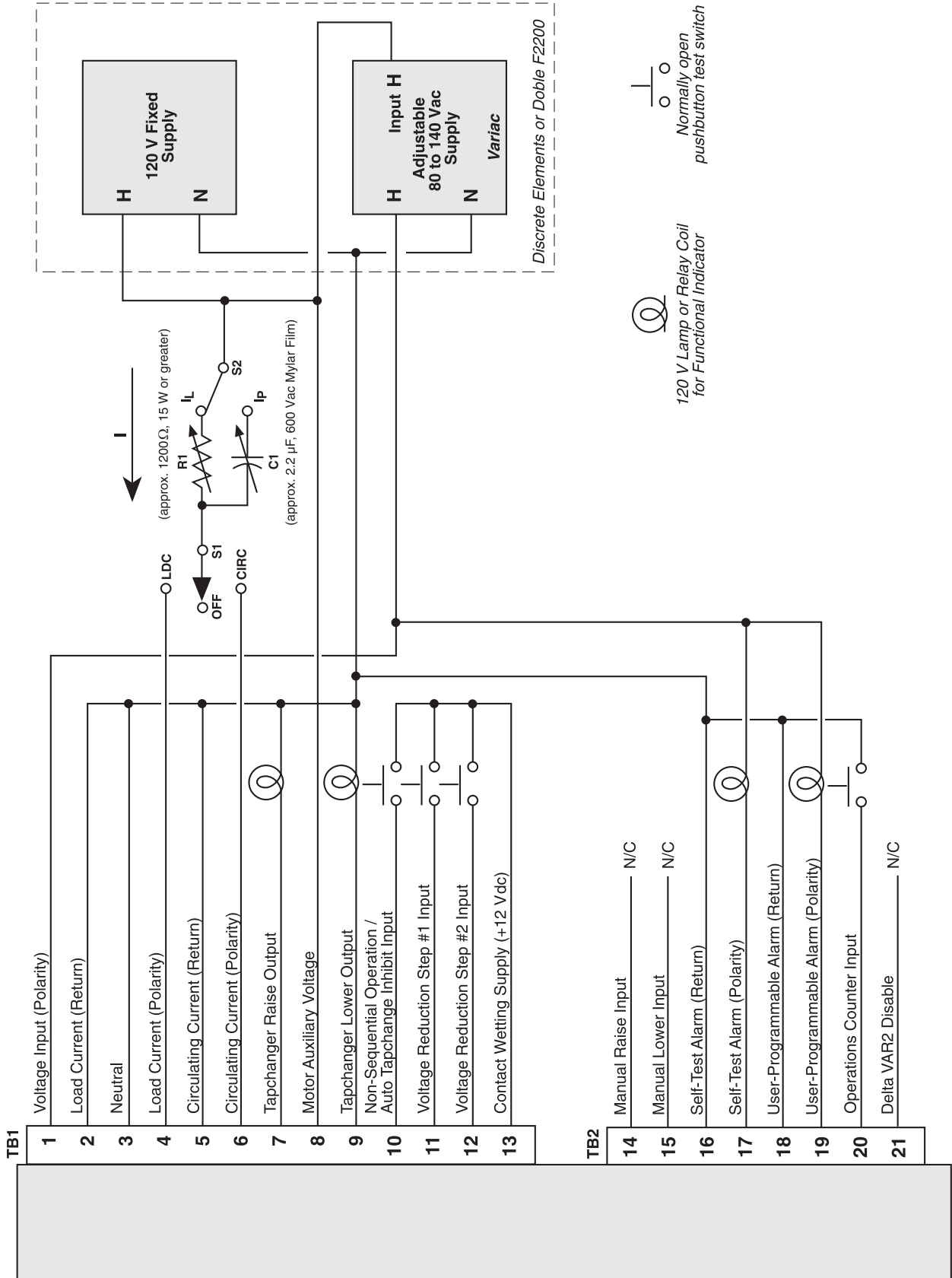

Figure 10 M-2067B Test Procedure External Connection

4.1 M-2001 Checkout Procedure

■ **NOTE:** This test of the M-2001 assumes that the unit remains connected to the M-2067B adapter panel.

Basic Operational Test

1. Set VT Ratio Correction = 0 V; CT/VT phasing = 0°
2. Apply 120.0 Vac to TB1-1 (hot) and TB1-3 (neutral) of the adapter panel.
3. Verify local voltage \approx input voltage ± 0.3 V.
4. Apply 100.0 mA in-phase current to TB1-4 (load current-polarity) and TB1-2 (load current-return) of the adapter panel. Verify **Control Load I** \approx 100 mA and **Power Factor** \approx 1.0 \pm 0.02.
5. Apply 100.0 mA 90° leading current to TB1-6 (circulating current-polarity) and TB1-5 (circulating current-return) of the adapter panel.
6. Verify **Control Circ I** \approx 100.0 mA \pm 2 mA.
7. Verify **Up**, **Down** and **Enter** buttons work.

—Checkout Procedure Complete—

4.2 In-Service Test

1. Set the M-2001 Tapchanger Control to display the Bias Voltage screen.
2. Press **Enter**.
3. Use **Up** and **Down** buttons to cause **RAISE** and **LOWER** outputs.

—In-Service Test Complete—

RETURN UNIT TO DESIRED SETTINGS

4.3 M-2067B Checkout Procedure

■ **NOTE:** All Beckwith Electric units are fully calibrated at the factory. There is no need to recalibrate the units before initial installation.

Inspect the **VOLTAGE** fuse to ensure that it is correctly sized and has not blown.

POWER

1. Remove any external connection between TB1-1 and TB1-8 which are located on the adapter panel printed circuit board.
2. Using a voltmeter, verify that the voltage applied to TB1-1 is nominal 120 Vac with respect to TB1-3 (neutral).

● **WARNING:** Voltage applied at TB1-1 may energize the regulator or transformer to a high voltage through the voltage transformer. Death or severe electrical shock can occur. Do not connect any voltage source at TB1-1.

▲ **CAUTION:** Do not reverse the ground and hot wires when connecting an external source.

- Apply motor auxiliary voltage to TB1-8 (motor auxiliary voltage) and TB1-3 (neutral). Verify that the motor runs in the proper direction when conditions of sensed voltage result in activation of the **RAISE** and **LOWER** outputs.

WARNING: In no case should the load current circuit be interrupted with the regulator or transformer energized. Do not remove auxiliary current transformers without shorting the current inputs. Death or severe electrical shock can occur.

- As shown in [Figure 11](#), temporarily place a shorting device across the LDC-CT secondary to short the line drop compensator circuit, and place another shorting device across TB1-5 and TB1-6 to short the circulating current paralleling input, for the load current check.
- Insert an ammeter between the polarity input and TB1-4.
- Open the load current shorting device and with a known load on the transformer or regulator, measure the current in the load current circuit to ensure that this current is correct for 0.2 A full load.
- Replace the shorting device across the load current input and remove the ammeter.
- Reconnect polarity to the unit and remove both jumpers.

The **LINE DROP COMPENSATOR** will be activated. Correct CT polarity can be checked by simply incorporating sufficient +R compensation. The regulator should time out and run so as to raise the output voltage.

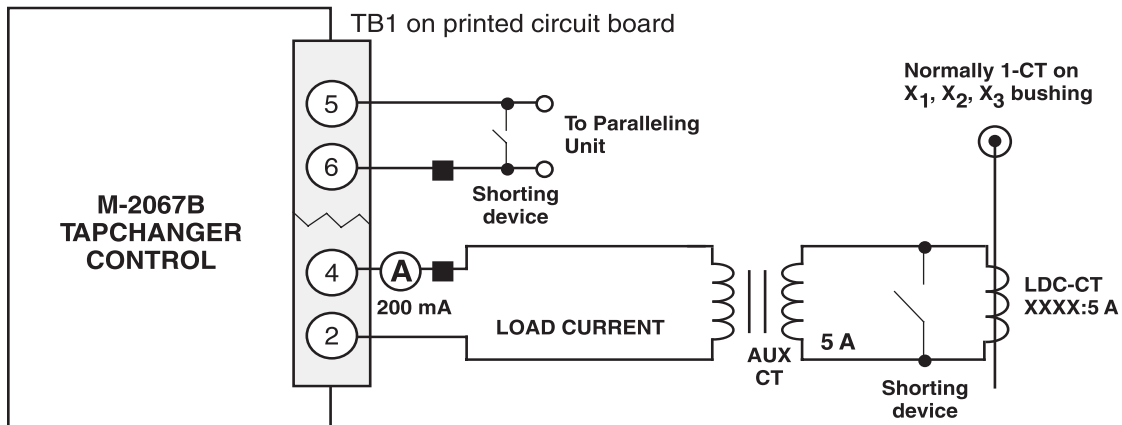

Figure 11 Setup for Current Checkout Procedure

5.0 Converting Westinghouse CVR/CVC Tapchanger Control to M-2067B/M-2001C Tapchanger Control

Introduction

The Beckwith Electric M-2067B/M-2001C Tapchanger Control is a replacement panel for the Westinghouse CVR/CVC control panel on transformers. However, it is not a direct replacement; three additional relays are needed. The M-2067B mounts in the same physical location as the existing control, 4 additional mounting holes will need to be drilled. The user is responsible for determining where and how to mount the required additional relays.

Instructions

1. Insure all local clearance and safety tagging rules and procedures are observed during the performance of this procedure.
2. Place the affected transformer(s) tapchanger existing control switch in the Manual mode of operation.

● WARNING: An open C.T. secondary will result in high voltage at C.T. terminals. Death, severe injury or damage to equipment can occur.

3. Determine where or if there is a method to short the current input, then proceed as follows:
 - a. If there is no method to short the current input, then the transformer must be removed from service.
 - b. If a shorting switch exists, then short the current input by opening the shorting switch.
 - c. If adding a jumper across the current input is an acceptable method of shorting the current input, then add a properly sized jumper.
4. Determine where or if there is a method to open the voltage input, then proceed as follows:
 - a. If the voltage input to the control can be isolated by opening a circuit breaker, then open the appropriate breaker.

● WARNING: Voltages up to 240 Vac could be present, contact can cause death, severe injury or damage to the control.

- b. If no circuit breaker or sliding link terminal block exists, then the voltage input wires can be cautiously removed and taped.
5. Determine where or if there is a method to open the motor power input, then proceed as follows:
 - a. If the motor power input to the control can be isolated by opening a circuit breaker, then open the appropriate breaker.

● WARNING: Voltages up to 240 Vac could be present, contact can cause death, severe injury or damage to the control.

- b. If no circuit breaker or sliding link terminal block is present to open the motor power input then, the wires can be cautiously removed and taped.
6. Label the wires coming to the existing control panel with the M-2067B designations listed in [Table 3](#) if they are not already labeled.
 7. Remove the wires from the terminal block of the existing CVR/CVC control. All external connections to the control should be disconnected at this time, if not, label and disconnect.
 8. Remove the mounting hardware used to mount the existing panel. Save the mounting hardware, as it may be used to mount the M-2067B panel.
 9. Cover equipment and wiring below where the holes will be drilled to prevent the metal filings from falling into them.

10. Utilize [Figure 9](#) to locate and drill the 4 mounting holes.
11. Determine where to mount the 3 additional relays. The relays are double pole double throw (DPDT), (use Potter & Brumfield KRP11AG or equivalent).

Westinghouse CVR/CVC Wire Identifier	M-2067B Terminal Block Wire Identifier	Comments
6	TB1-1	Regulated Voltage, Polarity
14	TB1-1	Regulated Voltage, Polarity
No Connection	TB1-2	No external connection to TB1-2. This is Load Current Return on the M-2067, there is a metal jumper from TB1-2 to TB1-3.
9	TB1-3	Regulated Voltage, Neutral
8	TB1-4	Load Current (0.2 A), Polarity (Load Current Return is TB1-2)
13	TB1-5	Circulating Current, Return
12	TB1-6	Circulating Current, Polarity
4	TB1-7	Raise
5	TB1-8	Motor Power
3	TB1-9	Lower
	Auxiliary Relay Wire Identifier	Relay connections are based on the Potter & Brumfield KRP11AG, if different relays are used review their connections.
2	120X-2	Auxiliary Relay (Coil) for Runback
7	120X-7	Auxiliary Relay (Coil) for Runback
6	120X-21	Auxiliary Relay Contact, Voltage Source
No Connection	120X-3 to AR-1	Runback when motor power lost and returns
16	AR-4 and AL-2	Lower Auxiliary Relay
15	AR-2 and AR-3	Raise Auxiliary Relay
9	AL-7 and AR-7	Ground
1	AR-8	Raise Output
10	AL-8	Lower Output
17	AR-6 and AL-6	Return
18	No Connection	Insulate Wire End

Table 3 Westinghouse CVR/CVC and M-2067B Terminal Block Designations

▲ CAUTION: Different manufactures of the relay sockets may have mounting patterns that are not the same.

12. Verify the mounting holes for the relay sockets, then mount the relay sockets.
13. Mount the M-2001C to the M-2067B Adapter Panel using the four screws and lock-washers provided in the cloth bag.
14. Plug the keyed blue connector ([Figure 5](#)) into the bottom of the M-2001C observing where the key is located ([Figure 6](#)).

15. If desired, bench testing may be performed as described in Section 4.0, Bench Test (M-2001 Connected to M-2067B).

● **WARNING: An open C.T. secondary will result in high voltage at C.T. terminals. Death, severe injury or damage to equipment can occur.**

● **WARNING: Voltages up to 240 Vac could be present, contact can cause death, severe injury or damage to the control.**

16. Install the M-2067B Adapter Panel using the original hardware.

■ **NOTE:** The terminal block of the CVR/CVC and the TB1 terminal block of the M-2067B are not the same; refer to [Table 3](#), [Figure 12](#) and [Figure 13](#).

● **WARNING: An open CT secondary will result in high voltage at CT terminals. Death, severe injury or damage to equipment can occur.**

● **WARNING: Voltages up to 240 Vac could be present, contact can cause death, severe injury or damage to the control.**

17. Reconnect the existing wires to the M-2067B and relays that have been added (relay connections are based on the Potter & Brumfield KRP11AG, if different relays are used review their connections).

● **WARNING: Voltages up to 240 Vac could be present, contact can cause death, severe injury or damage to the control.**

18. Restore the motor power input based on the isolation method utilized in Step 5.

● **WARNING: Voltages up to 240 Vac could be present, contact can cause death, severe injury or damage to the control.**

19. Restore the voltage input based on the isolation method utilized in Step 4.

● **WARNING: An open C.T. secondary will result in high voltage at C.T. terminals. Death, severe injury or damage to equipment can occur.**

20. Remove the current input shorting device based on the shorting method utilized in Step 3.

5.1 Check-out Instructions for Westinghouse CVR/CVC Conversion to M-2067B/M-2001C Tapchanger Control

1. Set the existing control switches to Local and Manual. Use the existing control switches to manually operate the tapchanger.

●WARNING: Voltages up to 240 Vac could be present, contact can cause death, severe injury or damage to the control.

2. Verify the following:
 - The M-2001C Tapchanger Control displays the **Local Voltage** screen.
 - The **OK** LED is illuminated.
 - No tapchanger operations occur.
 - The M-2001C **RAISE** or **LOWER** LED's may illuminate depending on the voltage present at that time.
3. Set the M-2001C Tapchanger Control settings as indicated in [Table 4](#) (these are factory default settings). Refer to the M-2001C Instruction Book if there are any questions regarding setting the M-2001C.

Check-out Settings	
Bandcenter	120.0 V Forward
Bandwidth	2.0 V Forward
LDC Resistance	0.0 V Forward
LDC Reactance	0.0 V Forward
Timer	30.0 Seconds
Block Raise	135.0 V
Block Lower	105.0 V
Deadband	2.0 V

Table 4 Check-out Settings

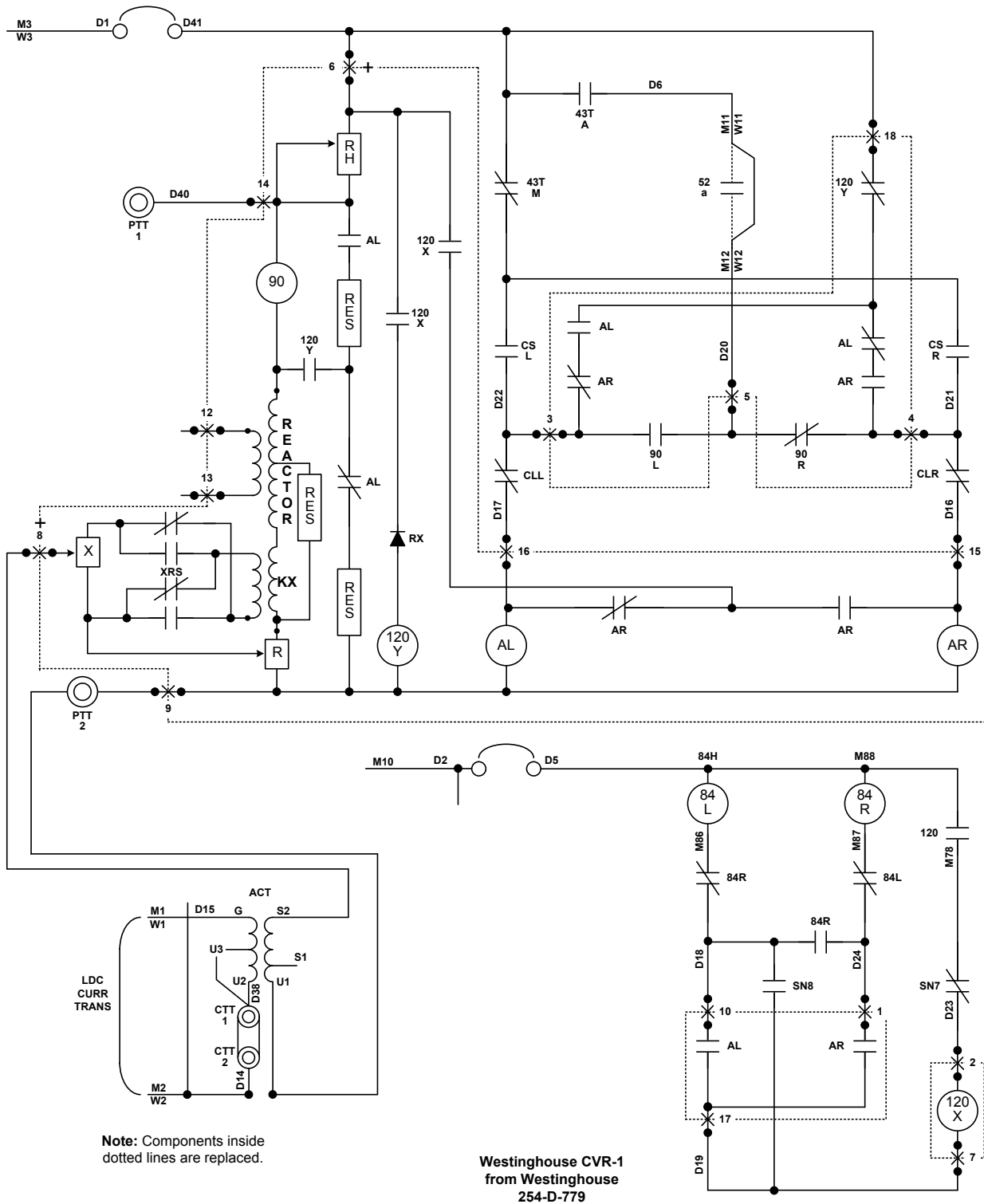

Figure 12 Westinghouse CVR-1 Replacement

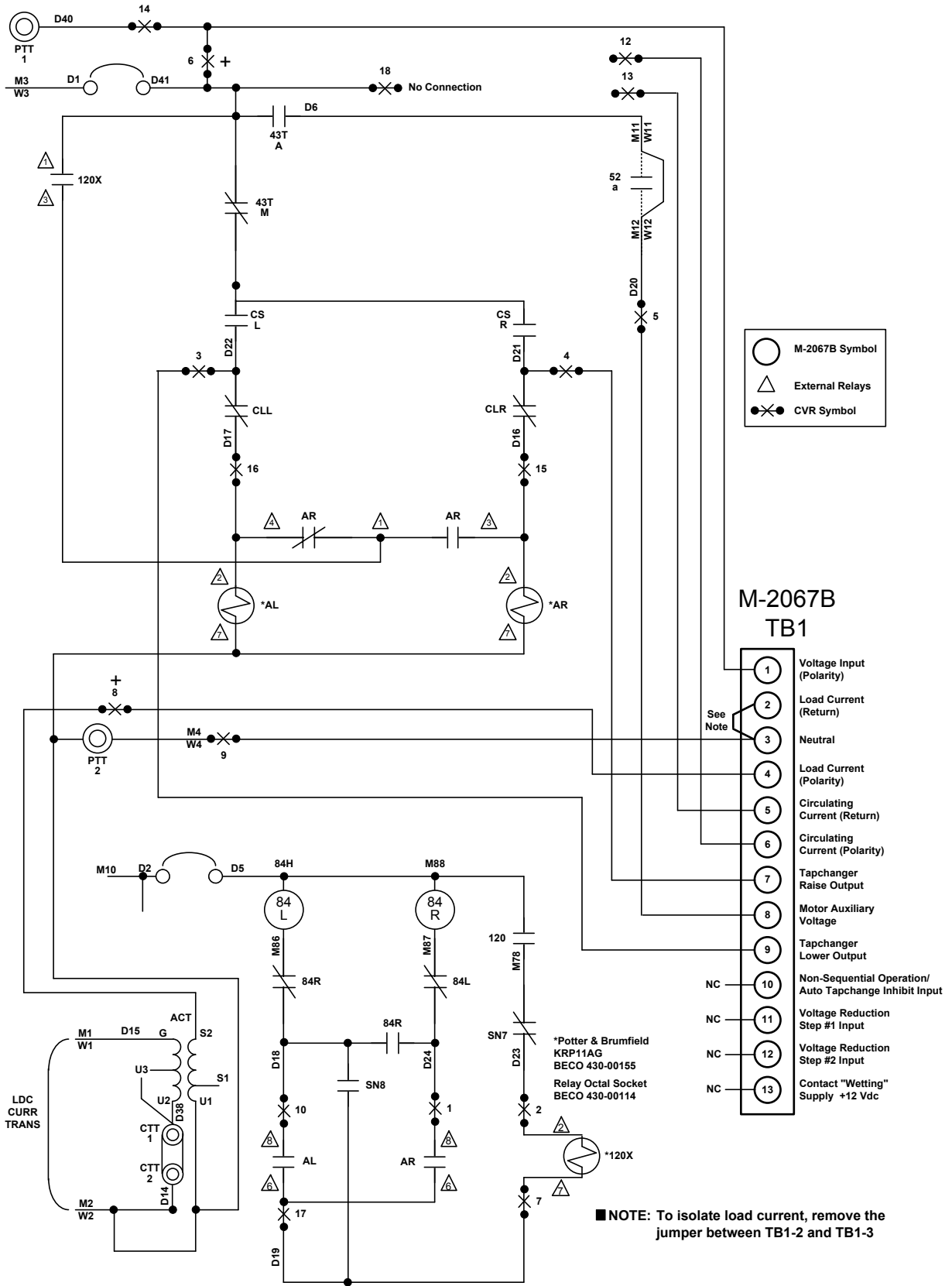

Figure 13 Westinghouse CVR-1 Replacement With M-2067B

4. Read the local voltage displayed by the M-2001C, then verify that the displayed voltage approximates the actual measured voltage.
5. Set the **Bandcenter** setting to the same value as the measured voltage.
6. Set the existing AUTO/MANUAL control switch to the MANUAL position.
7. Raise the tapchanger two to three tap positions. The M-2001C LOWER LED should illuminate but no operation should occur since the existing AUTO/MANUAL control switch is in the MANUAL position.
8. Verify the LOWER LED illuminates.
9. Set the existing AUTO/MANUAL control switch to the AUTO position, then verify the following:
 - The tapchanger starts to lower the voltage.
 - The tapchanger stops when it is within the 2 V bandwidth.
10. Set the existing AUTO/MANUAL control switch to the MANUAL position.
11. Lower the tapchanger two to three tap positions, then verify the following:
 - The M-2001C RAISE LED illuminates.
 - No tapchanger operation occurs since the existing AUTO/MANUAL control switch is in the MANUAL position.
12. Verify the RAISE LED illuminates.
13. Set the existing AUTO/MANUAL control switch to the AUTO position, then verify the following:
 - The tapchanger starts to raise the voltage.
 - The tapchanger stops when it is within the 2 V bandwidth.
14. Set the existing AUTO/MANUAL control switch to the MANUAL position.

● WARNING: An open CT secondary will result in high voltage at CT terminals. Death, severe injury or damage to equipment can occur.

15. Close shorting switch or remove the installed jumper, then verify the Control Load I value on the M-2001C is approximately the measured current input to the control.
16. Set the existing AUTO/MANUAL control switch to the MANUAL position.
17. Set the LDC Resistance value to 24, then verify the RAISE LED illuminates.
18. Set the LDC Resistance value to zero.
19. Return the M-2001C settings to the desired values for operation.
20. Set the existing AUTO/MANUAL control switch to the AUTO position.

BECKWITH ELECTRIC

6190 118th Avenue North • Largo, Florida 33773-3724 U.S.A.

PHONE (727) 544-2326

beckwithelectricshsupport@hubbell.com

www.beckwithelectric.com

ISO 9001:2015

Legal Information

Patent

The units described in this manual are covered by U.S. Patents, with other patents pending.

Buyer shall hold harmless and indemnify the Seller, its directors, officers, agents, and employees from any and all costs and expense, damage or loss, resulting from any alleged infringement of United States Letters Patent or rights accruing therefrom or trademarks, whether federal, state, or common law, arising from the Seller's compliance with Buyer's designs, specifications, or instructions.

Warranty

Seller hereby warrants that the goods which are the subject matter of this contract will be manufactured in a good workmanlike manner and all materials used herein will be new and reasonably suitable for the equipment. Seller warrants that if, during a period of five years from date of shipment of the equipment, the equipment rendered shall be found by the Buyer to be faulty or shall fail to perform in accordance with Seller's specifications of the product, Seller shall at his expense correct the same, provided, however, that Buyers shall ship the equipment prepaid to Seller's facility. The Seller's responsibility hereunder shall be limited to replacement value of the equipment furnished under this contract.

Seller makes no warranties expressed or implied other than those set out above. Seller specifically excludes the implied warranties of merchantability and fitness for a particular purpose. There are no warranties which extend beyond the description contained herein. In no event shall Seller be liable for consequential, exemplary, or punitive damages of whatever nature.

Any equipment returned for repair must be sent with transportation charges prepaid. The equipment must remain the property of the Buyer. The aforementioned warranties are void if the value of the unit is invoiced to the Seller at the time of return.

Indemnification

The Seller shall not be liable for any property damages whatsoever or for any loss or damage arising out of, connected with, or resulting from this contract, or from the performance or breach thereof, or from all services covered by or furnished under this contract.

In no event shall the Seller be liable for special, incidental, exemplary, or consequential damages, including but not limited to, loss of profits or revenue, loss of use of the equipment or any associated equipment, cost of capital, cost of purchased power, cost of substitute equipment, facilities or services, downtime costs, or claims or damages of customers or employees of the Buyer for such damages, regardless of whether said claim or damages is based on contract, warranty, tort including negligence, or otherwise.

Under no circumstances shall the Seller be liable for any personal injury whatsoever.

It is agreed that when the equipment furnished hereunder are to be used or performed in connection with any nuclear installation, facility, or activity, Seller shall have no liability for any nuclear damage, personal injury, property damage, or nuclear contamination to any property located at or near the site of the nuclear facility. Buyer agrees to indemnify and hold harmless the Seller against any and all liability associated therewith whatsoever whether based on contract, tort, or otherwise. Nuclear installation or facility means any nuclear reactor and includes the site on which any of the foregoing is located, all operations conducted on such site, and all premises used for such operations.

Notice:

Any illustrations and descriptions by Beckwith Electric are for the sole purpose of identification.

The drawings and/or specifications enclosed herein are the proprietary property of Beckwith Electric, and are issued in strict confidence; therefore, shall not be used as a basis of reproduction of the apparatus described therein without written permission of Beckwith Electric.

No illustration or description contained herein shall be construed as an express warranty of affirmation, promise, description, or sample, and any and all such express warranties are specifically excluded nor shall such illustration or description imply a warranty that the product is merchantable or fit for a particular purpose. There shall be no warranties which extend beyond those contained in the Beckwith Electric terms of sale.

BECKWITH ELECTRIC

6190 118th Avenue North • Largo, Florida 33773-3724 U.S.A.

PHONE (727) 544-2326

beckwithelectricshelp@hubbell.com

www.beckwithelectric.com

ISO 9001:2015