

TRANSFORMER SPECIFICATIONS	
PRIMARY VOLTAGE(S)	240x480
SECONDARY VOLTAGE(S)	120x240
RATED V.A.	3000
RATED FREQUENCY	50 / 60
INSULATION CLASS	180°C @ MAX. RISE 115°C
AGENCY APPROVALS	UL, CUL
ESTIMATED WEIGHT	53.0 LBS

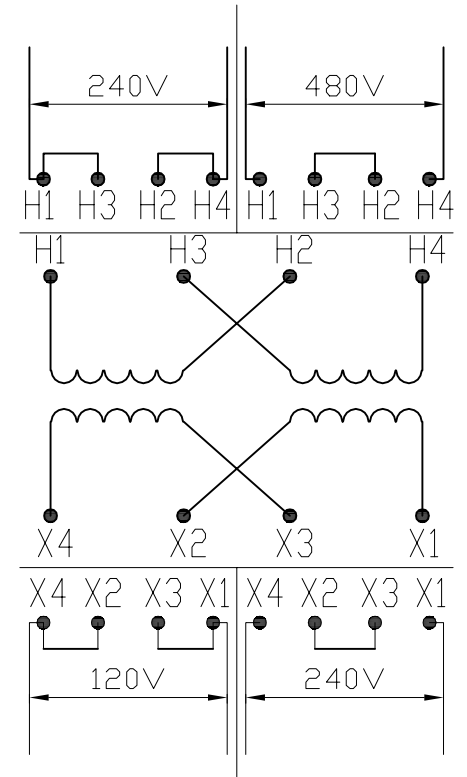
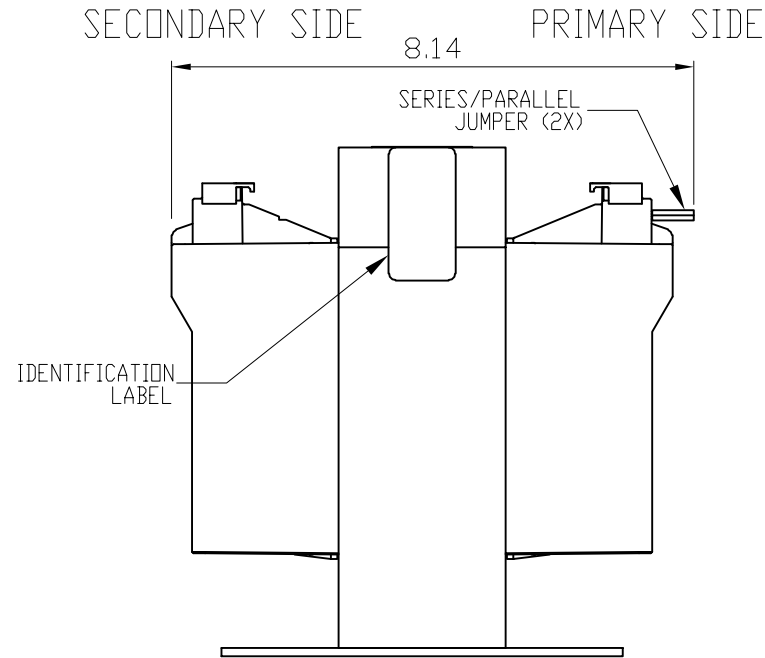
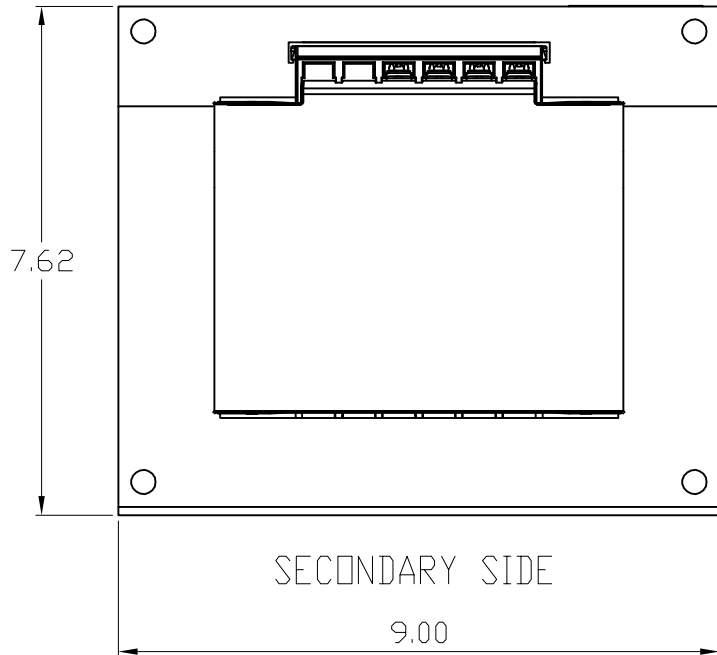

CONNECTION DIAGRAM

DIMENSIONS ARE IN INCHES

TOLERANCES:
 .XX ± .03
 .XXX ± .010
 ANGULAR: ± 1°

SOURCE N/A

MATERIAL N/A

FINISH N/A

DO NOT SCALE DRAWING

NAME	DATE
DRAWN BY: VS	05/14/2020
CHECKED BY:	

PROPRIETARY AND CONFIDENTIAL
 THE INFORMATION CONTAINED IN THIS DRAWING IS THE SOLE PROPERTY OF ACME. ANY REPRODUCTION IN PART OR AS A WHOLE WITHOUT THE WRITTEN PERMISSION OF ACME IS PROHIBITED.

DESCRIPTION: 3000 VA	
SIZE DWG. NO.	CE3000N014